

Service Manual



Signal Generator

R&S® SMB100A

1406.6000k03

with options

R&S® SMB-B112

R&S® SMB-B120

R&S® SMB-B131

R&S® SMB-B140

R&S® SMB-B140N



Dear Customer,

throughout this manual, the Signal Generator R&S® SMB100A is abbreviated as R&S SMB.

R&S® is a registered trademark of Rohde & Schwarz GmbH & Co. KG.
Trade names are trademarks of the owners.

Basic Safety Instructions

Always read through and comply with the following safety instructions!

All plants and locations of the Rohde & Schwarz group of companies make every effort to keep the safety standards of our products up to date and to offer our customers the highest possible degree of safety. Our products and the auxiliary equipment they require are designed, built and tested in accordance with the safety standards that apply in each case. Compliance with these standards is continuously monitored by our quality assurance system. The product described here has been designed, built and tested in accordance with the EC Certificate of Conformity and has left the manufacturer's plant in a condition fully complying with safety standards. To maintain this condition and to ensure safe operation, you must observe all instructions and warnings provided in this manual. If you have any questions regarding these safety instructions, the Rohde & Schwarz group of companies will be happy to answer them.

Furthermore, it is your responsibility to use the product in an appropriate manner. This product is designed for use solely in industrial and laboratory environments or, if expressly permitted, also in the field and must not be used in any way that may cause personal injury or property damage. You are responsible if the product is used for any purpose other than its designated purpose or in disregard of the manufacturer's instructions. The manufacturer shall assume no responsibility for such use of the product.

The product is used for its designated purpose if it is used in accordance with its product documentation and within its performance limits (see data sheet, documentation, the following safety instructions). Using the product requires technical skills and, in some cases, a basic knowledge of English. It is therefore essential that only skilled and specialized staff or thoroughly trained personnel with the required skills be allowed to use the product. If personal safety gear is required for using Rohde & Schwarz products, this will be indicated at the appropriate place in the product documentation. Keep the basic safety instructions and the product documentation in a safe place and pass them on to the subsequent users.

Observing the safety instructions will help prevent personal injury or damage of any kind caused by dangerous situations. Therefore, carefully read through and adhere to the following safety instructions before and when using the product. It is also absolutely essential to observe the additional safety instructions on personal safety, for example, that appear in relevant parts of the product documentation. In these safety instructions, the word "product" refers to all merchandise sold and distributed by the Rohde & Schwarz group of companies, including instruments, systems and all accessories. For product-specific information, see the data sheet and the product documentation.

Safety labels on products

The following safety labels are used on products to warn against risks and dangers.

Symbol	Meaning	Symbol	Meaning
	Notice, general danger location Observe product documentation		ON/OFF Power
	Caution when handling heavy equipment		Standby indication
	Danger of electric shock		Direct current (DC)

Basic Safety Instructions

Symbol	Meaning	Symbol	Meaning
	Caution ! Hot surface		Alternating current (AC)
	Protective conductor terminal To identify any terminal which is intended for connection to an external conductor for protection against electric shock in case of a fault, or the terminal of a protective earth		Direct/alternating current (DC/AC)
	Earth (Ground)		Class II Equipment to identify equipment meeting the safety requirements specified for Class II equipment (device protected by double or reinforced insulation)
	Frame or chassis Ground terminal		EU labeling for batteries and accumulators For additional information, see section "Waste disposal/Environmental protection", item 1.
	Be careful when handling electrostatic sensitive devices		EU labeling for separate collection of electrical and electronic devices For additional information, see section "Waste disposal/Environmental protection", item 2.
	Warning! Laser radiation For additional information, see section "Operation", item 7.		

Signal words and their meaning

The following signal words are used in the product documentation in order to warn the reader about risks and dangers.



Indicates a hazardous situation which, if not avoided, will result in death or serious injury.



Indicates a hazardous situation which, if not avoided, could result in death or serious injury.



Indicates a hazardous situation which, if not avoided, could result in minor or moderate injury.



Indicates information considered important, but not hazard-related, e.g. messages relating to property damage.
In the product documentation, the word ATTENTION is used synonymously.

These signal words are in accordance with the standard definition for civil applications in the European Economic Area. Definitions that deviate from the standard definition may also exist in other economic areas or military applications. It is therefore essential to make sure that the signal words described here are always used only in connection with the related product documentation and the related product. The use of signal words in connection with unrelated products or documentation can result in misinterpretation and in personal injury or material damage.

Basic Safety Instructions

Operating states and operating positions

The product may be operated only under the operating conditions and in the positions specified by the manufacturer, without the product's ventilation being obstructed. If the manufacturer's specifications are not observed, this can result in electric shock, fire and/or serious personal injury or death. Applicable local or national safety regulations and rules for the prevention of accidents must be observed in all work performed.

1. Unless otherwise specified, the following requirements apply to Rohde & Schwarz products: predefined operating position is always with the housing floor facing down, IP protection 2X, use only indoors, max. operating altitude 2000 m above sea level, max. transport altitude 4500 m above sea level. A tolerance of $\pm 10\%$ shall apply to the nominal voltage and $\pm 5\%$ to the nominal frequency, overvoltage category 2, pollution degree 2.
2. Do not place the product on surfaces, vehicles, cabinets or tables that for reasons of weight or stability are unsuitable for this purpose. Always follow the manufacturer's installation instructions when installing the product and fastening it to objects or structures (e.g. walls and shelves). An installation that is not carried out as described in the product documentation could result in personal injury or even death.
3. Do not place the product on heat-generating devices such as radiators or fan heaters. The ambient temperature must not exceed the maximum temperature specified in the product documentation or in the data sheet. Product overheating can cause electric shock, fire and/or serious personal injury or even death.

Electrical safety

If the information on electrical safety is not observed either at all or to the extent necessary, electric shock, fire and/or serious personal injury or death may occur.

1. Prior to switching on the product, always ensure that the nominal voltage setting on the product matches the nominal voltage of the mains-supply network. If a different voltage is to be set, the power fuse of the product may have to be changed accordingly.
2. In the case of products of safety class I with movable power cord and connector, operation is permitted only on sockets with a protective conductor contact and protective conductor.
3. Intentionally breaking the protective conductor either in the feed line or in the product itself is not permitted. Doing so can result in the danger of an electric shock from the product. If extension cords or connector strips are implemented, they must be checked on a regular basis to ensure that they are safe to use.
4. If there is no power switch for disconnecting the product from the mains, or if the power switch is not suitable for this purpose, use the plug of the connecting cable to disconnect the product from the mains. In such cases, always ensure that the power plug is easily reachable and accessible at all times. For example, if the power plug is the disconnecting device, the length of the connecting cable must not exceed 3 m. Functional or electronic switches are not suitable for providing disconnection from the AC supply network. If products without power switches are integrated into racks or systems, the disconnecting device must be provided at the system level.
5. Never use the product if the power cable is damaged. Check the power cables on a regular basis to ensure that they are in proper operating condition. By taking appropriate safety measures and carefully laying the power cable, ensure that the cable cannot be damaged and that no one can be hurt by, for example, tripping over the cable or suffering an electric shock.

Basic Safety Instructions

6. The product may be operated only from TN/TT supply networks fuse-protected with max. 16 A (higher fuse only after consulting with the Rohde & Schwarz group of companies).
7. Do not insert the plug into sockets that are dusty or dirty. Insert the plug firmly and all the way into the socket provided for this purpose. Otherwise, sparks that result in fire and/or injuries may occur.
8. Do not overload any sockets, extension cords or connector strips; doing so can cause fire or electric shocks.
9. For measurements in circuits with voltages $V_{rms} > 30$ V, suitable measures (e.g. appropriate measuring equipment, fuse protection, current limiting, electrical separation, insulation) should be taken to avoid any hazards.
10. Ensure that the connections with information technology equipment, e.g. PCs or other industrial computers, comply with the IEC 60950-1 / EN 60950-1 or IEC 61010-1 / EN 61010-1 standards that apply in each case.
11. Unless expressly permitted, never remove the cover or any part of the housing while the product is in operation. Doing so will expose circuits and components and can lead to injuries, fire or damage to the product.
12. If a product is to be permanently installed, the connection between the protective conductor terminal on site and the product's protective conductor must be made first before any other connection is made. The product may be installed and connected only by a licensed electrician.
13. For permanently installed equipment without built-in fuses, circuit breakers or similar protective devices, the supply circuit must be fuse-protected in such a way that anyone who has access to the product, as well as the product itself, is adequately protected from injury or damage.
14. Use suitable overvoltage protection to ensure that no overvoltage (such as that caused by a bolt of lightning) can reach the product. Otherwise, the person operating the product will be exposed to the danger of an electric shock.
15. Any object that is not designed to be placed in the openings of the housing must not be used for this purpose. Doing so can cause short circuits inside the product and/or electric shocks, fire or injuries.
16. Unless specified otherwise, products are not liquid-proof (see also section "Operating states and operating positions", item 1). Therefore, the equipment must be protected against penetration by liquids. If the necessary precautions are not taken, the user may suffer electric shock or the product itself may be damaged, which can also lead to personal injury.
17. Never use the product under conditions in which condensation has formed or can form in or on the product, e.g. if the product has been moved from a cold to a warm environment. Penetration by water increases the risk of electric shock.
18. Prior to cleaning the product, disconnect it completely from the power supply (e.g. AC supply network or battery). Use a soft, non-linting cloth to clean the product. Never use chemical cleaning agents such as alcohol, acetone or diluents for cellulose lacquers.

Operation

1. Operating the products requires special training and intense concentration. Make sure that persons who use the products are physically, mentally and emotionally fit enough to do so; otherwise, injuries or material damage may occur. It is the responsibility of the employer/operator to select suitable personnel for operating the products.

Basic Safety Instructions

2. Before you move or transport the product, read and observe the section titled "Transport".
3. As with all industrially manufactured goods, the use of substances that induce an allergic reaction (allergens) such as nickel cannot be generally excluded. If you develop an allergic reaction (such as a skin rash, frequent sneezing, red eyes or respiratory difficulties) when using a Rohde & Schwarz product, consult a physician immediately to determine the cause and to prevent health problems or stress.
4. Before you start processing the product mechanically and/or thermally, or before you take it apart, be sure to read and pay special attention to the section titled "Waste disposal/Environmental protection", item 1.
5. Depending on the function, certain products such as RF radio equipment can produce an elevated level of electromagnetic radiation. Considering that unborn babies require increased protection, pregnant women must be protected by appropriate measures. Persons with pacemakers may also be exposed to risks from electromagnetic radiation. The employer/operator must evaluate workplaces where there is a special risk of exposure to radiation and, if necessary, take measures to avert the potential danger.
6. Should a fire occur, the product may release hazardous substances (gases, fluids, etc.) that can cause health problems. Therefore, suitable measures must be taken, e.g. protective masks and protective clothing must be worn.
7. Laser products are given warning labels that are standardized according to their laser class. Lasers can cause biological harm due to the properties of their radiation and due to their extremely concentrated electromagnetic power. If a laser product (e.g. a CD/DVD drive) is integrated into a Rohde & Schwarz product, absolutely no other settings or functions may be used as described in the product documentation. The objective is to prevent personal injury (e.g. due to laser beams).
8. EMC classes (in line with EN 55011/CISPR 11, and analogously with EN 55022/CISPR 22, EN 55032/CISPR 32)
 - Class A equipment:
Equipment suitable for use in all environments except residential environments and environments that are directly connected to a low-voltage supply network that supplies residential buildings
Note: Class A equipment is intended for use in an industrial environment. This equipment may cause radio disturbances in residential environments, due to possible conducted as well as radiated disturbances. In this case, the operator may be required to take appropriate measures to eliminate these disturbances.
 - Class B equipment:
Equipment suitable for use in residential environments and environments that are directly connected to a low-voltage supply network that supplies residential buildings

Repair and service

1. The product may be opened only by authorized, specially trained personnel. Before any work is performed on the product or before the product is opened, it must be disconnected from the AC supply network. Otherwise, personnel will be exposed to the risk of an electric shock.

Basic Safety Instructions

- Adjustments, replacement of parts, maintenance and repair may be performed only by electrical experts authorized by Rohde & Schwarz. Only original parts may be used for replacing parts relevant to safety (e.g. power switches, power transformers, fuses). A safety test must always be performed after parts relevant to safety have been replaced (visual inspection, protective conductor test, insulation resistance measurement, leakage current measurement, functional test). This helps ensure the continued safety of the product.

Batteries and rechargeable batteries/cells

If the information regarding batteries and rechargeable batteries/cells is not observed either at all or to the extent necessary, product users may be exposed to the risk of explosions, fire and/or serious personal injury, and, in some cases, death. Batteries and rechargeable batteries with alkaline electrolytes (e.g. lithium cells) must be handled in accordance with the EN 62133 standard.

- Cells must not be taken apart or crushed.
- Cells or batteries must not be exposed to heat or fire. Storage in direct sunlight must be avoided. Keep cells and batteries clean and dry. Clean soiled connectors using a dry, clean cloth.
- Cells or batteries must not be short-circuited. Cells or batteries must not be stored in a box or in a drawer where they can short-circuit each other, or where they can be short-circuited by other conductive materials. Cells and batteries must not be removed from their original packaging until they are ready to be used.
- Cells and batteries must not be exposed to any mechanical shocks that are stronger than permitted.
- If a cell develops a leak, the fluid must not be allowed to come into contact with the skin or eyes. If contact occurs, wash the affected area with plenty of water and seek medical aid.
- Improperly replacing or charging cells or batteries that contain alkaline electrolytes (e.g. lithium cells) can cause explosions. Replace cells or batteries only with the matching Rohde & Schwarz type (see parts list) in order to ensure the safety of the product.
- Cells and batteries must be recycled and kept separate from residual waste. Rechargeable batteries and normal batteries that contain lead, mercury or cadmium are hazardous waste. Observe the national regulations regarding waste disposal and recycling.

Transport

- The product may be very heavy. Therefore, the product must be handled with care. In some cases, the user may require a suitable means of lifting or moving the product (e.g. with a lift-truck) to avoid back or other physical injuries.
- Handles on the products are designed exclusively to enable personnel to transport the product. It is therefore not permissible to use handles to fasten the product to or on transport equipment such as cranes, fork lifts, wagons, etc. The user is responsible for securely fastening the products to or on the means of transport or lifting. Observe the safety regulations of the manufacturer of the means of transport or lifting. Noncompliance can result in personal injury or material damage.
- If you use the product in a vehicle, it is the sole responsibility of the driver to drive the vehicle safely and properly. The manufacturer assumes no responsibility for accidents or collisions. Never use the product in a moving vehicle if doing so could distract the driver of the vehicle. Adequately secure the product in the vehicle to prevent injuries or other damage in the event of an accident.

Instrucciones de seguridad elementales

Waste disposal/Environmental protection

1. Specially marked equipment has a battery or accumulator that must not be disposed of with unsorted municipal waste, but must be collected separately. It may only be disposed of at a suitable collection point or via a Rohde & Schwarz customer service center.
2. Waste electrical and electronic equipment must not be disposed of with unsorted municipal waste, but must be collected separately.
Rohde & Schwarz GmbH & Co. KG has developed a disposal concept and takes full responsibility for take-back obligations and disposal obligations for manufacturers within the EU. Contact your Rohde & Schwarz customer service center for environmentally responsible disposal of the product.
3. If products or their components are mechanically and/or thermally processed in a manner that goes beyond their intended use, hazardous substances (heavy-metal dust such as lead, beryllium, nickel) may be released. For this reason, the product may only be disassembled by specially trained personnel. Improper disassembly may be hazardous to your health. National waste disposal regulations must be observed.
4. If handling the product releases hazardous substances or fuels that must be disposed of in a special way, e.g. coolants or engine oils that must be replenished regularly, the safety instructions of the manufacturer of the hazardous substances or fuels and the applicable regional waste disposal regulations must be observed. Also observe the relevant safety instructions in the product documentation. The improper disposal of hazardous substances or fuels can cause health problems and lead to environmental damage.

For additional information about environmental protection, visit the Rohde & Schwarz website.

Instrucciones de seguridad elementales

¡Es imprescindible leer y cumplir las siguientes instrucciones e informaciones de seguridad!

El principio del grupo de empresas Rohde & Schwarz consiste en tener nuestros productos siempre al día con los estándares de seguridad y de ofrecer a nuestros clientes el máximo grado de seguridad. Nuestros productos y todos los equipos adicionales son siempre fabricados y examinados según las normas de seguridad vigentes. Nuestro sistema de garantía de calidad controla constantemente que sean cumplidas estas normas. El presente producto ha sido fabricado y examinado según el certificado de conformidad de la UE y ha salido de nuestra planta en estado impecable según los estándares técnicos de seguridad. Para poder preservar este estado y garantizar un funcionamiento libre de peligros, el usuario deberá atenerse a todas las indicaciones, informaciones de seguridad y notas de alerta. El grupo de empresas Rohde & Schwarz está siempre a su disposición en caso de que tengan preguntas referentes a estas informaciones de seguridad.

Además queda en la responsabilidad del usuario utilizar el producto en la forma debida. Este producto está destinado exclusivamente al uso en la industria y el laboratorio o, si ha sido expresamente autorizado, para aplicaciones de campo y de ninguna manera deberá ser utilizado de modo que alguna persona/cosa pueda sufrir daño. El uso del producto fuera de sus fines definidos o sin tener en cuenta las instrucciones del fabricante queda en la responsabilidad del usuario. El fabricante no se hace en ninguna forma responsable de consecuencias a causa del mal uso del producto.

Instrucciones de seguridad elementales

Se parte del uso correcto del producto para los fines definidos si el producto es utilizado conforme a las indicaciones de la correspondiente documentación del producto y dentro del margen de rendimiento definido (ver hoja de datos, documentación, informaciones de seguridad que siguen). El uso del producto hace necesarios conocimientos técnicos y ciertos conocimientos del idioma inglés. Por eso se debe tener en cuenta que el producto solo pueda ser operado por personal especializado o personas instruidas en profundidad con las capacidades correspondientes. Si fuera necesaria indumentaria de seguridad para el uso de productos de Rohde & Schwarz, encontraría la información debida en la documentación del producto en el capítulo correspondiente. Guarde bien las informaciones de seguridad elementales, así como la documentación del producto, y entréguelas a usuarios posteriores.

Tener en cuenta las informaciones de seguridad sirve para evitar en lo posible lesiones o daños por peligros de toda clase. Por eso es imprescindible leer detalladamente y comprender por completo las siguientes informaciones de seguridad antes de usar el producto, y respetarlas durante el uso del producto. Deberán tenerse en cuenta todas las demás informaciones de seguridad, como p. ej. las referentes a la protección de personas, que encontrarán en el capítulo correspondiente de la documentación del producto y que también son de obligado cumplimiento. En las presentes informaciones de seguridad se recogen todos los objetos que distribuye el grupo de empresas Rohde & Schwarz bajo la denominación de "producto", entre ellos también aparatos, instalaciones así como toda clase de accesorios. Los datos específicos del producto figuran en la hoja de datos y en la documentación del producto.

Señalización de seguridad de los productos

Las siguientes señales de seguridad se utilizan en los productos para advertir sobre riesgos y peligros.

Símbolo	Significado	Símbolo	Significado
	Aviso: punto de peligro general Observar la documentación del producto		Tensión de alimentación de PUESTA EN MARCHA / PARADA
	Atención en el manejo de dispositivos de peso elevado		Indicación de estado de espera (standby)
	Peligro de choque eléctrico		Corriente continua (DC)
	Advertencia: superficie caliente		Corriente alterna (AC)
	Conexión a conductor de protección		Corriente continua / Corriente alterna (DC/AC)
	Conexión a tierra		El aparato está protegido en su totalidad por un aislamiento doble (reforzado)
	Conexión a masa		Distintivo de la UE para baterías y acumuladores Más información en la sección "Eliminación/protección del medio ambiente", punto 1.

Instrucciones de seguridad elementales

Símbolo	Significado	Símbolo	Significado
	Aviso: Cuidado en el manejo de dispositivos sensibles a la electrostática (ESD)		Distintivo de la UE para la eliminación por separado de dispositivos eléctricos y electrónicos Más información en la sección "Eliminación/protección del medio ambiente", punto 2.
	Advertencia: rayo láser Más información en la sección "Funcionamiento", punto 7.		

Palabras de señal y su significado

En la documentación del producto se utilizan las siguientes palabras de señal con el fin de advertir contra riesgos y peligros.



Indica una situación de peligro que, si no se evita, causa lesiones graves o incluso la muerte.



Indica una situación de peligro que, si no se evita, puede causar lesiones graves o incluso la muerte.



Indica una situación de peligro que, si no se evita, puede causar lesiones leves o moderadas.



Indica información que se considera importante, pero no en relación con situaciones de peligro; p. ej., avisos sobre posibles daños materiales.

En la documentación del producto se emplea de forma sinónima el término CUIDADO.

Las palabras de señal corresponden a la definición habitual para aplicaciones civiles en el área económica europea. Pueden existir definiciones diferentes a esta definición en otras áreas económicas o en aplicaciones militares. Por eso se deberá tener en cuenta que las palabras de señal aquí descritas sean utilizadas siempre solamente en combinación con la correspondiente documentación del producto y solamente en combinación con el producto correspondiente. La utilización de las palabras de señal en combinación con productos o documentaciones que no les correspondan puede llevar a interpretaciones equivocadas y tener por consecuencia daños en personas u objetos.

Estados operativos y posiciones de funcionamiento

El producto solamente debe ser utilizado según lo indicado por el fabricante respecto a los estados operativos y posiciones de funcionamiento sin que se obstruya la ventilación. Si no se siguen las indicaciones del fabricante, pueden producirse choques eléctricos, incendios y/o lesiones graves con posible consecuencia de muerte. En todos los trabajos deberán ser tenidas en cuenta las normas nacionales y locales de seguridad del trabajo y de prevención de accidentes.

Instrucciones de seguridad elementales

1. Si no se convino de otra manera, es para los productos Rohde & Schwarz válido lo que sigue: como posición de funcionamiento se define por principio la posición con el suelo de la caja para abajo, modo de protección IP 2X, uso solamente en estancias interiores, utilización hasta 2000 m sobre el nivel del mar, transporte hasta 4500 m sobre el nivel del mar. Se aplicará una tolerancia de $\pm 10\%$ sobre el voltaje nominal y de $\pm 5\%$ sobre la frecuencia nominal. Categoría de sobrecarga eléctrica 2, índice de suciedad 2.
2. No sitúe el producto encima de superficies, vehículos, estantes o mesas, que por sus características de peso o de estabilidad no sean aptos para él. Siga siempre las instrucciones de instalación del fabricante cuando instale y asegure el producto en objetos o estructuras (p. ej. paredes y estantes). Si se realiza la instalación de modo distinto al indicado en la documentación del producto, se pueden causar lesiones o, en determinadas circunstancias, incluso la muerte.
3. No ponga el producto sobre aparatos que generen calor (p. ej. radiadores o calefactores). La temperatura ambiente no debe superar la temperatura máxima especificada en la documentación del producto o en la hoja de datos. En caso de sobrecalentamiento del producto, pueden producirse choques eléctricos, incendios y/o lesiones graves con posible consecuencia de muerte.

Seguridad eléctrica

Si no se siguen (o se siguen de modo insuficiente) las indicaciones del fabricante en cuanto a seguridad eléctrica, pueden producirse choques eléctricos, incendios y/o lesiones graves con posible consecuencia de muerte.

1. Antes de la puesta en marcha del producto se deberá comprobar siempre que la tensión preseleccionada en el producto coincida con la de la red de alimentación eléctrica. Si es necesario modificar el ajuste de tensión, también se deberán cambiar en caso dado los fusibles correspondientes del producto.
2. Los productos de la clase de protección I con alimentación móvil y enchufe individual solamente podrán enchufarse a tomas de corriente con contacto de seguridad y con conductor de protección conectado.
3. Queda prohibida la interrupción intencionada del conductor de protección, tanto en la toma de corriente como en el mismo producto. La interrupción puede tener como consecuencia el riesgo de que el producto sea fuente de choques eléctricos. Si se utilizan cables alargadores o regletas de enchufe, deberá garantizarse la realización de un examen regular de los mismos en cuanto a su estado técnico de seguridad.
4. Si el producto no está equipado con un interruptor para desconectarlo de la red, o bien si el interruptor existente no resulta apropiado para la desconexión de la red, el enchufe del cable de conexión se deberá considerar como un dispositivo de desconexión. El dispositivo de desconexión se debe poder alcanzar fácilmente y debe estar siempre bien accesible. Si, p. ej., el enchufe de conexión a la red es el dispositivo de desconexión, la longitud del cable de conexión no debe superar 3 m). Los interruptores selectores o electrónicos no son aptos para el corte de la red eléctrica. Si se integran productos sin interruptor en bastidores o instalaciones, se deberá colocar el interruptor en el nivel de la instalación.
5. No utilice nunca el producto si está dañado el cable de conexión a red. Compruebe regularmente el correcto estado de los cables de conexión a red. Asegúrese, mediante las medidas de protección y de instalación adecuadas, de que el cable de conexión a red no pueda ser dañado o de que nadie pueda ser dañado por él, p. ej. al tropezar o por un choque eléctrico.

Instrucciones de seguridad elementales

6. Solamente está permitido el funcionamiento en redes de alimentación TN/TT aseguradas con fusibles de 16 A como máximo (utilización de fusibles de mayor amperaje solo previa consulta con el grupo de empresas Rohde & Schwarz).
7. Nunca conecte el enchufe en tomas de corriente sucias o llenas de polvo. Introduzca el enchufe por completo y fuertemente en la toma de corriente. La no observación de estas medidas puede provocar chispas, fuego y/o lesiones.
8. No sobrecargue las tomas de corriente, los cables alargadores o las regletas de enchufe ya que esto podría causar fuego o choques eléctricos.
9. En las mediciones en circuitos de corriente con una tensión $U_{\text{eff}} > 30 \text{ V}$ se deberán tomar las medidas apropiadas para impedir cualquier peligro (p. ej. medios de medición adecuados, seguros, limitación de tensión, corte protector, aislamiento etc.).
10. Para la conexión con dispositivos informáticos como un PC o un ordenador industrial, debe comprobarse que éstos cumplan los estándares IEC60950-1/EN60950-1 o IEC61010-1/EN 61010-1 válidos en cada caso.
11. A menos que esté permitido expresamente, no retire nunca la tapa ni componentes de la carcasa mientras el producto esté en servicio. Esto pone a descubierto los cables y componentes eléctricos y puede causar lesiones, fuego o daños en el producto.
12. Si un producto se instala en un lugar fijo, se deberá primero conectar el conductor de protección fijo con el conductor de protección del producto antes de hacer cualquier otra conexión. La instalación y la conexión deberán ser efectuadas por un electricista especializado.
13. En el caso de dispositivos fijos que no estén provistos de fusibles, interruptor automático ni otros mecanismos de seguridad similares, el circuito de alimentación debe estar protegido de modo que todas las personas que puedan acceder al producto, así como el producto mismo, estén a salvo de posibles daños.
14. Todo producto debe estar protegido contra sobretensión (debida p. ej. a una caída del rayo) mediante los correspondientes sistemas de protección. Si no, el personal que lo utilice quedará expuesto al peligro de choque eléctrico.
15. No debe introducirse en los orificios de la caja del aparato ningún objeto que no esté destinado a ello. Esto puede producir cortocircuitos en el producto y/o puede causar choques eléctricos, fuego o lesiones.
16. Salvo indicación contraria, los productos no están impermeabilizados (ver también el capítulo "Estados operativos y posiciones de funcionamiento", punto 1). Por eso es necesario tomar las medidas necesarias para evitar la entrada de líquidos. En caso contrario, existe peligro de choque eléctrico para el usuario o de daños en el producto, que también pueden redundar en peligro para las personas.
17. No utilice el producto en condiciones en las que pueda producirse o ya se hayan producido condensaciones sobre el producto o en el interior de éste, como p. ej. al desplazarlo de un lugar frío a otro caliente. La entrada de agua aumenta el riesgo de choque eléctrico.
18. Antes de la limpieza, desconecte por completo el producto de la alimentación de tensión (p. ej. red de alimentación o batería). Realice la limpieza de los aparatos con un paño suave, que no se deshilache. No utilice bajo ningún concepto productos de limpieza químicos como alcohol, acetona o diluyentes para lacas nitrocelulósicas.

Instrucciones de seguridad elementales

Funcionamiento

1. El uso del producto requiere instrucciones especiales y una alta concentración durante el manejo. Debe asegurarse que las personas que manejen el producto estén a la altura de los requerimientos necesarios en cuanto a aptitudes físicas, psíquicas y emocionales, ya que de otra manera no se pueden excluir lesiones o daños de objetos. El empresario u operador es responsable de seleccionar el personal usuario apto para el manejo del producto.
2. Antes de desplazar o transportar el producto, lea y tenga en cuenta el capítulo "Transporte".
3. Como con todo producto de fabricación industrial no puede quedar excluida en general la posibilidad de que se produzcan alergias provocadas por algunos materiales empleados —los llamados alérgenos (p. ej. el níquel)—. Si durante el manejo de productos Rohde & Schwarz se producen reacciones alérgicas, como p. ej. irritaciones cutáneas, estornudos continuos, enrojecimiento de la conjuntiva o dificultades respiratorias, debe avisarse inmediatamente a un médico para investigar las causas y evitar cualquier molestia o daño a la salud.
4. Antes de la manipulación mecánica y/o térmica o el desmontaje del producto, debe tenerse en cuenta imprescindiblemente el capítulo "Eliminación/protección del medio ambiente", punto 1.
5. Ciertos productos, como p. ej. las instalaciones de radiocomunicación RF, pueden a causa de su función natural, emitir una radiación electromagnética aumentada. Deben tomarse todas las medidas necesarias para la protección de las mujeres embarazadas. También las personas con marcapasos pueden correr peligro a causa de la radiación electromagnética. El empresario/operador tiene la obligación de evaluar y señalar las áreas de trabajo en las que exista un riesgo elevado de exposición a radiaciones.
6. Tenga en cuenta que en caso de incendio pueden desprenderse del producto sustancias tóxicas (gases, líquidos etc.) que pueden generar daños a la salud. Por eso, en caso de incendio deben usarse medidas adecuadas, como p. ej. máscaras antigás e indumentaria de protección.
7. Los productos con láser están provistos de indicaciones de advertencia normalizadas en función de la clase de láser del que se trate. Los rayos láser pueden provocar daños de tipo biológico a causa de las propiedades de su radiación y debido a su concentración extrema de potencia electromagnética. En caso de que un producto Rohde & Schwarz contenga un producto láser (p. ej. un lector de CD/DVD), no debe usarse ninguna otra configuración o función aparte de las descritas en la documentación del producto, a fin de evitar lesiones (p. ej. debidas a irradiación láser).
8. Clases de compatibilidad electromagnética (conforme a EN 55011 / CISPR 11; y en analogía con EN 55022 / CISPR 22, EN 55032 / CISPR 32)
 - Aparato de clase A:
Aparato adecuado para su uso en todos los entornos excepto en los residenciales y en aquellos conectados directamente a una red de distribución de baja tensión que suministra corriente a edificios residenciales.
Nota: Los aparatos de clase A están destinados al uso en entornos industriales. Estos aparatos pueden causar perturbaciones radioeléctricas en entornos residenciales debido a posibles perturbaciones guiadas o radiadas. En este caso, se le podrá solicitar al operador que tome las medidas adecuadas para eliminar estas perturbaciones.
 - Aparato de clase B:
Aparato adecuado para su uso en entornos residenciales, así como en aquellos conectados directamente a una red de distribución de baja tensión que suministra corriente a edificios residenciales.

Instrucciones de seguridad elementales

Reparación y mantenimiento

1. El producto solamente debe ser abierto por personal especializado con autorización para ello. Antes de manipular el producto o abrirlo, es obligatorio desconectarlo de la tensión de alimentación, para evitar toda posibilidad de choque eléctrico.
2. El ajuste, el cambio de partes, el mantenimiento y la reparación deberán ser efectuadas solamente por electricistas autorizados por Rohde & Schwarz. Si se reponen partes con importancia para los aspectos de seguridad (p. ej. el enchufe, los transformadores o los fusibles), solamente podrán ser sustituidos por partes originales. Después de cada cambio de partes relevantes para la seguridad deberá realizarse un control de seguridad (control a primera vista, control del conductor de protección, medición de resistencia de aislamiento, medición de la corriente de fuga, control de funcionamiento). Con esto queda garantizada la seguridad del producto.

Baterías y acumuladores o celdas

Si no se siguen (o se siguen de modo insuficiente) las indicaciones en cuanto a las baterías y acumuladores o celdas, pueden producirse explosiones, incendios y/o lesiones graves con posible consecuencia de muerte. El manejo de baterías y acumuladores con electrolitos alcalinos (p. ej. celdas de litio) debe seguir el estándar EN 62133.

1. No deben desmontarse, abrirse ni triturarse las celdas.
2. Las celdas o baterías no deben someterse a calor ni fuego. Debe evitarse el almacenamiento a la luz directa del sol. Las celdas y baterías deben mantenerse limpias y secas. Limpiar las conexiones sucias con un paño seco y limpio.
3. Las celdas o baterías no deben cortocircuitarse. Es peligroso almacenar las celdas o baterías en estuches o cajones en cuyo interior puedan cortocircuitarse por contacto recíproco o por contacto con otros materiales conductores. No deben extraerse las celdas o baterías de sus embalajes originales hasta el momento en que vayan a utilizarse.
4. Las celdas o baterías no deben someterse a impactos mecánicos fuertes indebidos.
5. En caso de falta de estanqueidad de una celda, el líquido vertido no debe entrar en contacto con la piel ni los ojos. Si se produce contacto, lavar con agua abundante la zona afectada y avisar a un médico.
6. En caso de cambio o recarga inadecuados, las celdas o baterías que contienen electrolitos alcalinos (p. ej. las celdas de litio) pueden explotar. Para garantizar la seguridad del producto, las celdas o baterías solo deben ser sustituidas por el tipo Rohde & Schwarz correspondiente (ver lista de recambios).
7. Las baterías y celdas deben reciclarse y no deben tirarse a la basura doméstica. Las baterías o acumuladores que contienen plomo, mercurio o cadmio deben tratarse como residuos especiales. Respete en esta relación las normas nacionales de eliminación y reciclaje.

Transporte

1. El producto puede tener un peso elevado. Por eso es necesario desplazarlo o transportarlo con precaución y, si es necesario, usando un sistema de elevación adecuado (p. ej. una carretilla elevadora), a fin de evitar lesiones en la espalda u otros daños personales.

Instrucciones de seguridad elementales

2. Las asas instaladas en los productos sirven solamente de ayuda para el transporte del producto por personas. Por eso no está permitido utilizar las asas para la sujeción en o sobre medios de transporte como p. ej. grúas, carretillas elevadoras de horquilla, carros etc. Es responsabilidad suya fijar los productos de manera segura a los medios de transporte o elevación. Para evitar daños personales o daños en el producto, siga las instrucciones de seguridad del fabricante del medio de transporte o elevación utilizado.
3. Si se utiliza el producto dentro de un vehículo, recae de manera exclusiva en el conductor la responsabilidad de conducir el vehículo de manera segura y adecuada. El fabricante no asumirá ninguna responsabilidad por accidentes o colisiones. No utilice nunca el producto dentro de un vehículo en movimiento si esto pudiera distraer al conductor. Asegure el producto dentro del vehículo debidamente para evitar, en caso de un accidente, lesiones u otra clase de daños.

Eliminación/protección del medio ambiente

1. Los dispositivos marcados contienen una batería o un acumulador que no se debe desechar con los residuos domésticos sin clasificar, sino que debe ser recogido por separado. La eliminación se debe efectuar exclusivamente a través de un punto de recogida apropiado o del servicio de atención al cliente de Rohde & Schwarz.
2. Los dispositivos eléctricos usados no se deben desechar con los residuos domésticos sin clasificar, sino que deben ser recogidos por separado.
Rohde & Schwarz GmbH & Co.KG ha elaborado un concepto de eliminación de residuos y asume plenamente los deberes de recogida y eliminación para los fabricantes dentro de la UE. Para desechar el producto de manera respetuosa con el medio ambiente, dirijase a su servicio de atención al cliente de Rohde & Schwarz.
3. Si se trabaja de manera mecánica y/o térmica cualquier producto o componente más allá del funcionamiento previsto, pueden liberarse sustancias peligrosas (polvos con contenido de metales pesados como p. ej. plomo, berilio o níquel). Por eso el producto solo debe ser desmontado por personal especializado con formación adecuada. Un desmontaje inadecuado puede ocasionar daños para la salud. Se deben tener en cuenta las directivas nacionales referentes a la eliminación de residuos.
4. En caso de que durante el trato del producto se formen sustancias peligrosas o combustibles que deban tratarse como residuos especiales (p. ej. refrigerantes o aceites de motor con intervalos de cambio definidos), deben tenerse en cuenta las indicaciones de seguridad del fabricante de dichas sustancias y las normas regionales de eliminación de residuos. Tenga en cuenta también en caso necesario las indicaciones de seguridad especiales contenidas en la documentación del producto. La eliminación incorrecta de sustancias peligrosas o combustibles puede causar daños a la salud o daños al medio ambiente.

Se puede encontrar más información sobre la protección del medio ambiente en la página web de Rohde & Schwarz.

Instructions for Electrostatic Discharge Protection

NOTICE

Risk of damaging electronic components

To avoid damage of electronic components, the operational site must be protected against electrostatic discharge (ESD).

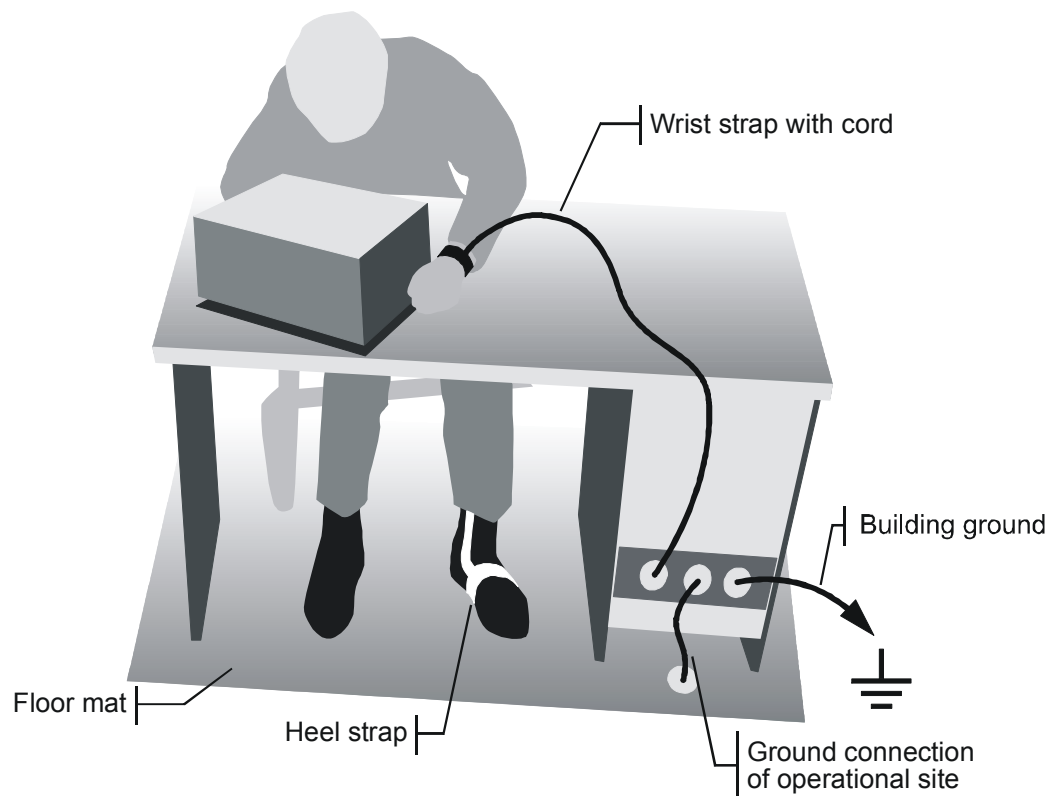

The following two methods of ESD protection may be used together or separately:

- Wrist strap with cord to ground connection
 - Conductive floor mat and heel strap combination
-

Instrucciones para la protección contra descargas electrostáticas

AVISO

Riesgo de avería de los componentes electrónicos

Para evitar averías en los componentes electrónicos, el área de trabajo tiene que estar protegido contra descargas electrostáticas ESD (electrostatic discharge).

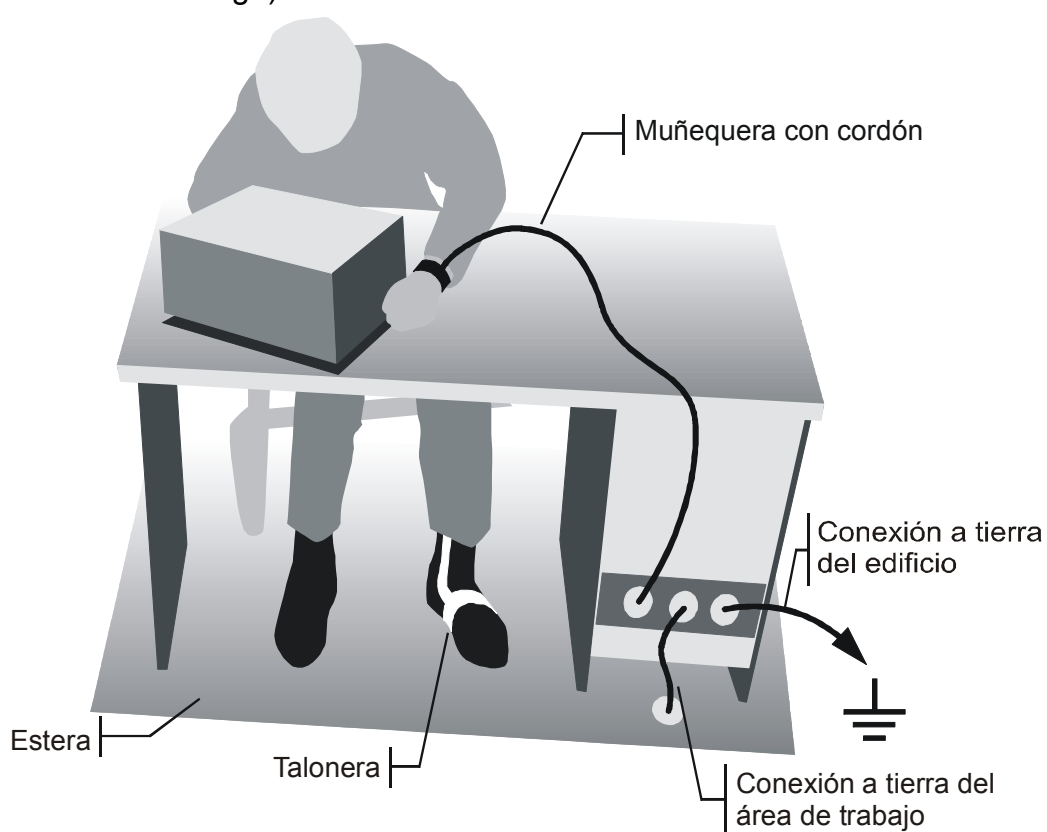

Los siguientes dos métodos de protección ESD pueden ser usados juntos o separados:

- Muñequera con cordón para conexión a tierra
- Combinación de estera antiestática y talonera

Safety Instructions for Units with Removable Cabinet

⚠ WARNING

Danger of injuries

When removing the rear feet, the unit can slip out of the cabinet.

Put the unit onto the front handles, before removing the rear feet and taking off the cabinet. Thus the risk of personal injuries and damages to the unit is avoided.

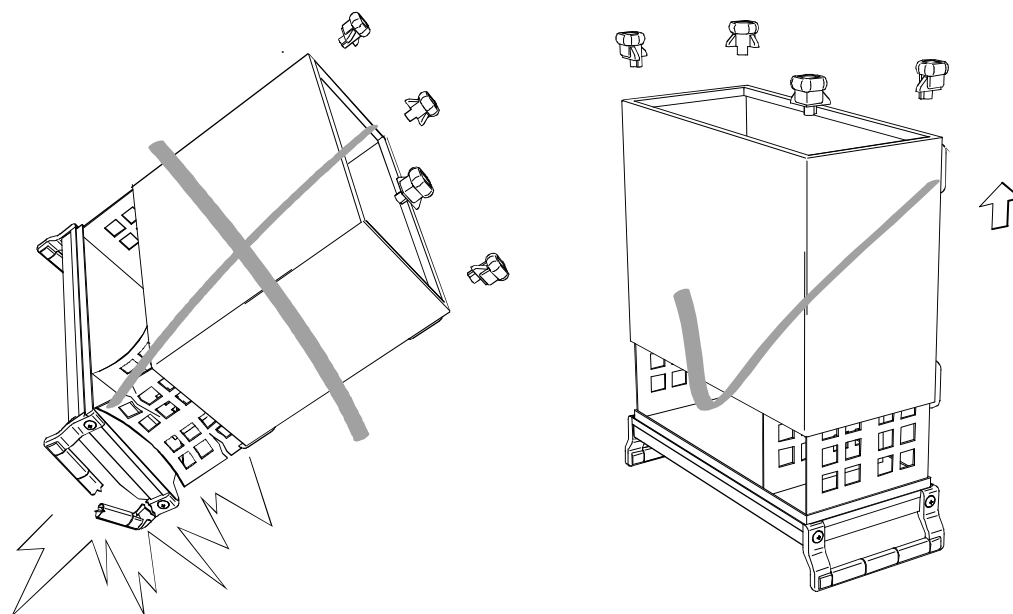

When mounting the cabinet take care not to pin in the fingers. Also pay attention not to damage or pull off cables. Screw the rear feet back on immediately after mounting the cabinet. Do not move the unit with the rear feet missing.

Informaciones de seguridad para aparatos con tubo de quita y pon

⚠ ADVERTENCIA

Peligro de heridas

Al sacar los piés de la pared posterior puede deslizarse el aparato fuera de la caja.

Posicionar el aparato de manera segura sobre las asas delanteras, antes de sacar los piés de la pared posterior y entonces sacar la caja. De esta manera evitarán el riesgo de daños en personas y daños en el aparato.

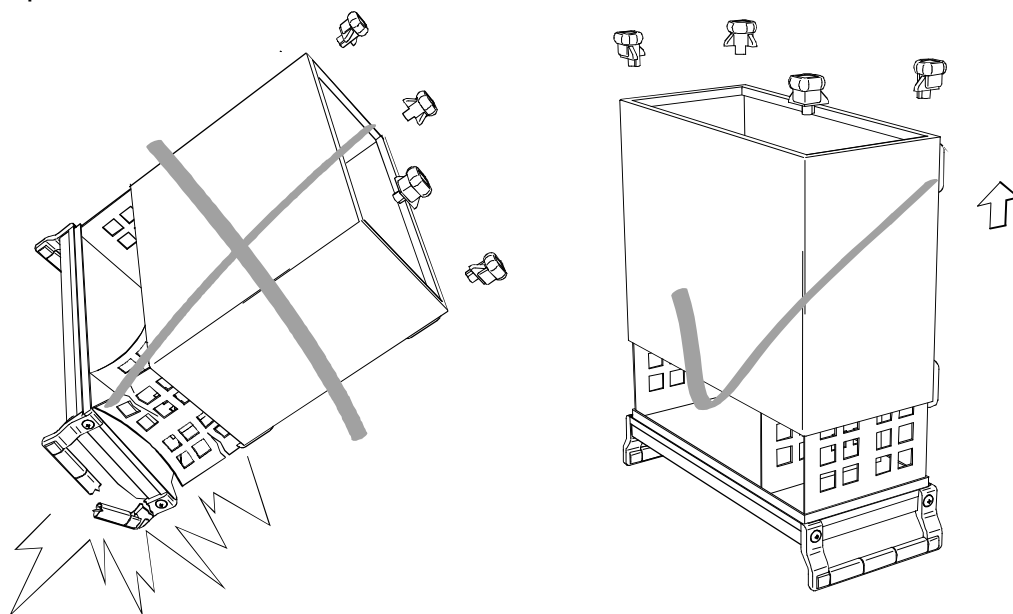

Existe el riesgo de heridas en el momento de poner otra vez la caja, como por ejemplo posiblemente engancharse los dedos. Por favor tengan además en cuenta de que no se enganchen o desconecten cables. Por favor atornillen los piés de la pared posterior directamente despues de poner la caja. No muevan el aparato nunca sin que los piés de la pared posterior estén atornillados.

Procedure in Case of Service and Ordering of Spare Parts

This section contains information on shipping an instrument to your service center and ordering spare parts.

Please contact your local Rohde & Schwarz service center if you need service or repair work of your equipment or to order spare parts. You can find the current address of your representative on our homepage www.rohde-schwarz.com.

Shipping the Instrument

We require the following information in order to answer your inquiry fast and correctly and to determine whether the warranty is still valid for your instrument:

- Instrument model
- Serial number
- Firmware version
- Must the instrument be returned with this firmware?
- Detailed error description in case of repair
- Indication of desired calibration
- Contact person for possible questions

In some countries, an RMA process is available for the return shipment of the instrument. For details, contact your local representative.

When shipping the instrument, be careful to provide for sufficient mechanical and antistatic protection.

- Use the original packaging for transporting or shipping the instrument. The protective caps for the front and rear prevent damage to the operating elements and the connectors.
- If you do not use the original packaging, provide for sufficient padding to prevent the instrument from slipping inside the box. Wrap antistatic packing foil around the instrument to protect it from electrostatic charging.

Rohde & Schwarz offers repair and calibrations of the test systems it produces. The calibration documentation fulfills ISO 17025 requirements.

Shipping Defective Modules

Also when shipping a module, be careful to provide for sufficient mechanical and antistatic protection.

- Ship the module in a sturdy, padded box.
- Wrap the module in antistatic foil.

If the packaging is only antistatic but not conductive, additional conductive packaging is required. The additional packaging is not required if the tightly fitting packaging is conductive.

Exception:

If the module contains a battery, the tightly fitting packaging must always consist of antistatic, non-chargeable material to protect the battery from being discharged.

Ordering Spare Parts

To deliver spare parts promptly and correctly, we need the following information:

- Stock number (see list of spare parts in chapter "Documents")
- Designation
- Component number according to list of spare parts
- Number of pieces
- Instrument type for which the spare part is needed
- Instrument stock number
- Instrument serial number
- Contact person for possible questions

Refurbished Modules

Refurbished modules are an economical alternative to original modules. Bear in mind that refurbished modules are not new, but repaired and fully tested parts. They may have traces from use, but they are electrically and mechanically equivalent to new modules.

Your Rohde & Schwarz representative will be happy to inform you about which modules are available as refurbished modules.

Taking Back Defective Replaced Modules

Defective modules of the replacement program which cannot be repaired are taken back within three months following delivery. A repurchasing value is credited.

Excluded are parts which cannot be repaired, e.g. printed boards that are burnt, broken or damaged by attempts to repair them, incomplete modules, and parts with severe mechanical damage.

Please return the defective replacement modules, together with the accompanying document for returned merchandise, which you received with the spare module. We need the following information:

- Stock number, serial number and designation of the removed part
- Detailed error description
- Stock number, serial number and type of instrument from which the module was removed
- Date of removal
- Name of the engineer/technician who replaced the module
- R&S ordering number
- Service reference number (if available)

Chapter Overview

Index

Basic Safety Instructions

Instructions for Electrostatic Discharge Protection

Safety Instructions for Units with Removable Cabinet

Procedure in Case of Service and Ordering of Spare Parts

Chapter 1: Performance Test

Chapter 2: Procedures after Module Replacement

Chapter 3: Repair

Chapter 4: Software Update / Installing Options

Chapter 5: Documents

Index

A

Adjustments	2.1
Amplitude modulation	
Test procedure	1.33, 1.38

B

Boot problems	
Troubleshooting	3.22

C

Check Front Panel	3.22
-------------------------	------

D

Documents	5.1
-----------------	-----

E

External level correction	2.4
---------------------------------	-----

F

Fan does not work	3.21
Firmware update	4.1
Frequency	
Test procedure	1.8
Frequency Error	3.41
Fuses	3.54

L

Level	
Test procedure	1.24
Lithium Battery	2.3

M

Measuring equipment	
Troubleshooting	3.19
Modulation	
Analog	
Test assembly	1.2, 1.3
Modulation generator	
Test procedure	1.31
Module replacement	3.51
Modules overview	3.52

O

Option	
Installation	4.3
List	4.3
Output impedance	
Test assembly	1.5

P

Phase noise	
Test assembly	1.4
Power cables	5.2
Pulse modulation	
Test procedure	1.47, 1.50

R

Rated characteristics	
Test procedures	1.7
Reference frequency	
Test procedure	1.7
Replacement	
Module	3.51
Replacing Fuses	3.54
Residual	
AM	
Test assembly	1.3

S

Software update	4.1
Spectral purity	
Test procedure	1.13
Switch-on problems	3.19

T

Test assembly	1.2, 1.3
Analog modulations	1.2, 1.3
Output impedance	1.5
Residual AM	1.3
SSB phase noise	1.4
Test equipment	1.1
Test frequency (recommended)	1.6
Test procedure	
Amplitude modulation	1.33, 1.38
Frequency	1.8
Level	1.24
Modulation generator	1.31
Pulse modulation	1.47, 1.50
Spectral purity	1.13
Test procedures	1.7
Troubleshooting	
Problems with booting	3.22
Switch-on problems	3.19

U

Unit cannot be switched on	3.19
Update of firmware	4.1
Update of software	4.1
USB Cable Test	3.23

Contents - Chapter 1 "Performance Test"

1	Checking the Rated Characteristics	1.1
1.1	Measuring Equipment and Accessories	1.1
1.2	Test Assemblies	1.2
1.2.1	Standard Test Assembly for Analog Modulations	1.2
1.2.2	Test Assembly for Pulse Modulation	1.3
1.2.3	Test Assembly for Residual AM	1.3
1.2.4	Test Assembly for SSB Phase Noise and Jitter	1.4
1.2.5	Test Assembly for Output Impedance (VSWR)	1.5
1.2.6	Test Assembly for Setting Time	1.5
1.3	Preparation, Recommended Test Frequencies and Levels	1.6
1.4	Test Procedures	1.7
1.4.1	Reference Frequency	1.7
1.4.1.1	Output of Internal Reference	1.7
1.4.1.2	Input for External Reference	1.7
1.4.2	Frequency	1.8
1.4.2.1	Frequency Setting	1.8
1.4.2.2	Setting Time	1.9
1.4.3	Spectral Purity	1.13
1.4.3.1	Harmonics	1.13
1.4.3.2	Subharmonics	1.14
1.4.3.3	Nonharmonics	1.15
1.4.3.4	Non-systematic nonharmonics	1.17
1.4.3.5	Wideband Noise	1.17
1.4.3.6	SSB Phase Noise	1.19
1.4.3.7	Residual FM	1.21
1.4.3.8	Residual AM	1.23
1.4.4	Level Data	1.24
1.4.4.1	Level Uncertainty	1.24
1.4.4.2	Output Impedance	1.27
1.4.4.3	Setting Time	1.28
1.4.5	Internal Modulation Generator	1.31
1.4.6	Amplitude Modulation	1.33
1.4.6.1	AM Setting Uncertainty	1.33
1.4.6.2	AM Distortion	1.35
1.4.6.3	AM Frequency Response	1.36
1.4.6.4	Synchronous PhiM with AM	1.37
1.4.7	Frequency Modulation	1.38
1.4.7.1	Test Methods	1.38
1.4.7.2	FM Setting Uncertainty	1.38
1.4.7.3	FM Distortion	1.39
1.4.7.4	FM Frequency Response	1.40
1.4.7.5	Synchronous AM with FM	1.42
1.4.7.6	Carrier Frequency Offset with FM	1.43
1.4.8	Phase Modulation	1.44
1.4.8.1	PhiM Setting Uncertainty	1.44
1.4.8.2	PhiM Distortion	1.44
1.4.8.3	PhiM Frequency Response	1.45

- 1.4.9 Pulse Modulation1.47
 - 1.4.9.1 ON/OFF Ratio1.47
 - 1.4.9.2 Rise/ Fall Time1.48
 - 1.4.9.3 Video Crosstalk1.49
- 1.4.10 Pulse Generator1.50
 - 1.4.10.1 PULSE VIDEO1.50
- 1.4.11 Hardware Signals1.50
 - 1.4.11.1 SIGNAL VALID.....1.50

1 Checking the Rated Characteristics

This performance test describes the steps for testing the R&S SMB100A Signal Generator family and the installed options with respect to function and compliance with specifications.

In the following, the term DUT (Device under Test) is used for any signal generator of this family. The tests to be performed depend on the installed options. The values and limits are given in the last released version of the data sheet at time of production of the respective instrument.

1.1 Measuring Equipment and Accessories

Table 1-1 Measuring equipment and accessories

Item	Type of Instrument	Required Characteristics	Suitable Instrument	R&S Order No.
1.	Signal Source Analyzer including - low phase noise option - Correlation Extension - demodulator for analog modulations - frequency counter - RF preamplifier	Fmin = 100 kHz, Fmax ≥ RF _{max} AM / FM / PM demodulation bandwidth ≥ 30 MHz 0.1 Hz resolution Fmin = 100 kHz, Fmax = RF _{max} Gain 20 dB	R&S FSUP26 with options R&S FS-B60 and R&S FS-B61 and R&S FS-B23 and R&S FS-B25 or R&S FSUP50 with options R&S FS-B60 and R&S FS-B61 and R&S FS-B25 and and additional RF preamplifier 3.6 GHz to 40 GHz SHF 804 TL	1166.3505.27 1169.5544.03 1305.2500.23 1157.0907.02 1144.9298.02 1166.3505.51 1169.5544.03 1305.2500.50 1144.9298.02
2.	Alternative to item 1 Spectrum analyzer including - demodulator for analog modulations - frequency counter - RF preamplifier	Fmin = 100 kHz; Fmax ≥ RF _{max} AM / FM / PM demodulation bandwidth ≥ 30 MHz resolution 0.1 Hz Fmin = 100 kHz, Fmax = RF _{max} Gain 20 dB	R&S FSMR43 with options R&S FSU-B25 and R&S FS-B223 or R&S FS-B24 or R&S FSQ40 with options R&S FSU-B24 R&S FS-K7	1313.9200.43 1044.9298.02 1157.1955.26 1157.2100.50 1313.9100.40 1157.2100.50 1141.1796.02
3.	Phase Noise Test Set (included in Signal Source Analyzer item 1)	Mixer: 10 MHz to RF _{max} , f < 1 GHz: 1 GHz < f ≤ 40 GHz: Preamplifier (item 9): branching filter 20 MHz, DC decoupling after the mixer	Minicircuits ZFM2H Marki M4-0140LK	
4.	Reference source for SSB noise measurements (included in Signal Source Analyzer item 1)	Identical generator as DUT or generator with at least 10 dB lower SSB noise as DUT Frequency range up to RF _{max}	R&S SMB100A with adequate frequency option or R&S SMF100A only for f ≥ 1000 MHz	1406.6000K03 1167.0000.02
5.	RF power meter	100 kHz to RF _{max}	R&S NRP with R&S NRP-Z55	1143.8500.02 1138.2008.03

Item	Type of Instrument	Required Characteristics	Suitable Instrument	R&S Order No.
6.	Oscilloscope	Bandwidth ≥ 100 MHz, two channels with DC coupling	R&S RTM1052 or Hameg HM1508-2	1305.0008.52
7.	Feed-through termination	50 Ω , BNC system	R&S RAD	0289.8966.00
8.	Pulse generator	Pulse repetition frequency at least 10 kHz	R&S SMB100A equipped with option K23	1406.6000K03
9.	Zero Bias Schottky Detector	50 Ω	Krytar 703BK	
10.	AC/DC voltmeter	10 Hz to 10 MHz	R&S URE3	350.5315.03
11.	VSWR bridge	directivity > 30 dB 0.2 MHz to 4 GHz 4 GHz to 12.75 GHz	R&S ZRC Agilent 773D	1039.9492.55
12.	High precision RF adapter	PC-3.50 male – N female Return loss > 26 dB DC to 13 GHz	Rosenberger Series RPC-N 03 S 105-K00 S3	
13.	RF attenuator	DC to RF _{max} , 10 dB, system N		
14.	RF attenuator	DC to RF _{max} , 3 dB, system N		
15.	Signal generator	0.2 MHz to 12.75 GHz	R&S SMB100A with adequate frequency option	1406.6000K03
16.	RF power amplifier (only for option R&S SMB- B30)	60 MHz to 300 MHz power > 33 dBm	Mini Circuits ZHL-03-5WF	

1.2 Test Assemblies

1.2.1 Standard Test Assembly for Analog Modulations

Test equipment	<ul style="list-style-type: none"> - RF analyzer (Table 1-1, item 1) - Signal generator (Table 1-1, item 15)
Test setup	The RF analyzer is used as a modulation analyzer. The LF generator of the signal generator is used as modulation source in case of external modulation.

1.2.2 Test Assembly for Pulse Modulation

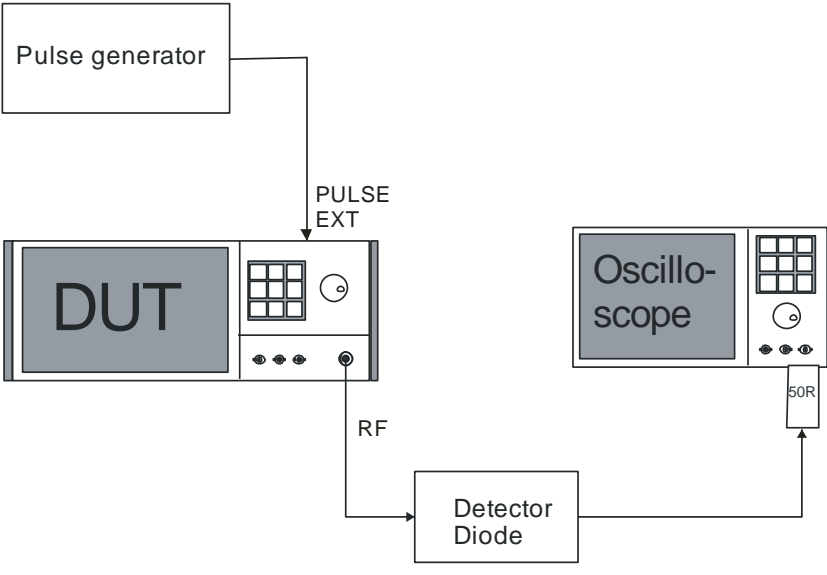
Test equipment	<ul style="list-style-type: none"> - Oscilloscope (Table 1-1, item 6) - Detector Diode (Table 1-1, item 9) - Pulse generator (Table 1-1, item 8)
Test setup	<p>The pulsed RF is detected with a detector diode and analyzed with an oscilloscope.</p>
 <p>The diagram illustrates the test setup for pulse modulation. It shows a Pulse generator connected to the PULSE EXT input of a Device Under Test (DUT). The RF output of the DUT is connected to a Detector Diode. The output of the Detector Diode is connected to a 50R resistor, which is then connected to the input of an Oscilloscope.</p>	

1.2.3 Test Assembly for Residual AM

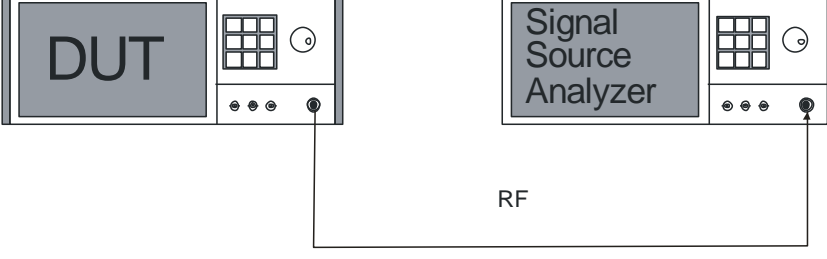
Test equipment	<ul style="list-style-type: none"> - RF analyzer (Table 1-1, item 1)
Test setup	 <p>The diagram illustrates the test setup for residual AM. It shows a Signal Source Analyzer connected to the RF input of a Device Under Test (DUT).</p>

1.2.4 Test Assembly for SSB Phase Noise and Jitter

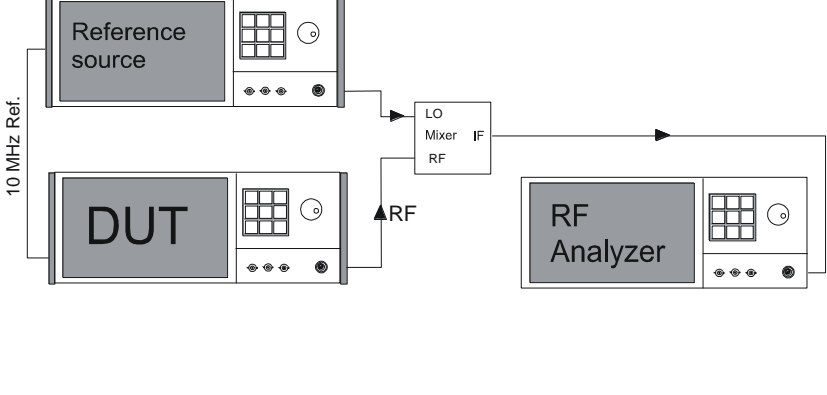
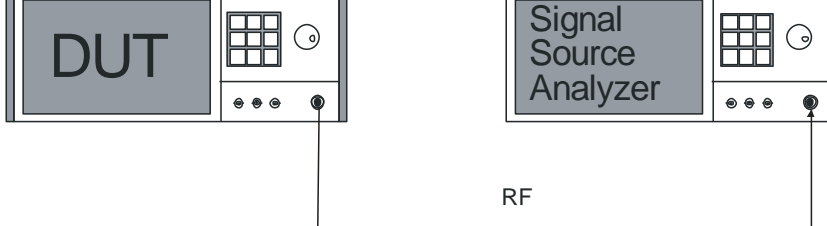
<p>Test equipment</p>	<ul style="list-style-type: none"> - Signal Source Analyzer ((Table 1-1 item 1) or - SSB reference source (Table 1-1 item 4) - Phase noise test assembly (Table 1-1 item 3) - Spectrum analyzer (Table 1-1 item 2)
<p>Test setup with phase noise test set</p>	 <p>The diagram shows a Reference source and a DUT connected to a LO Mixer. The Reference source provides a 10 MHz Ref. signal to the LO Mixer. The DUT provides an RF signal to the LO Mixer. The LO Mixer outputs an IF signal to an RF Analyzer.</p>
<p>Test setup with Signal Source Analyzer</p>	 <p>The diagram shows a DUT and a Signal Source Analyzer connected via an RF line.</p>

1.2.5 Test Assembly for Output Impedance (VSWR)

Test setup for instruments equipped with frequency option R&S SMB-B112L or R&S SMB-B112

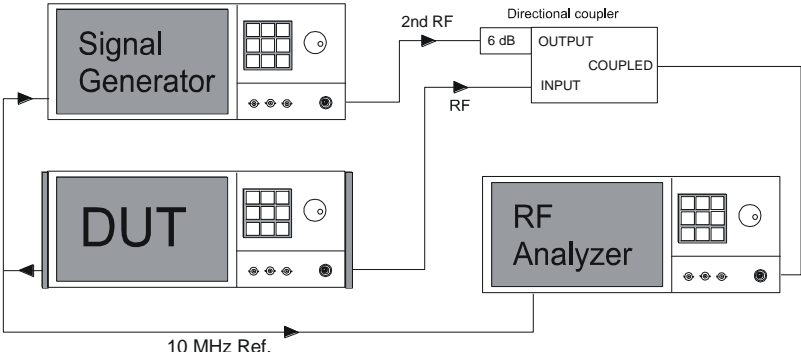
<p>Test equipment</p>	<ul style="list-style-type: none"> - VSWR bridge (Table 1-1, item 11), - Second signal generator (Table 1-1, item 15) - Spectrum analyzer (Table 1-1, item 1)
<p>Test setup</p>	
	<p>Note: The INPUT of the directional coupler is directly screwed to the DUT by use of a high precision PC-3.5 to N RF adapter. (Table 1-1, item 12) The second signal generator is connected to the line connector (OUTPUT), the analyzer to the coupling output (COUPLED) of the directional coupler.</p>

1.2.6 Test Assembly for Setting Time

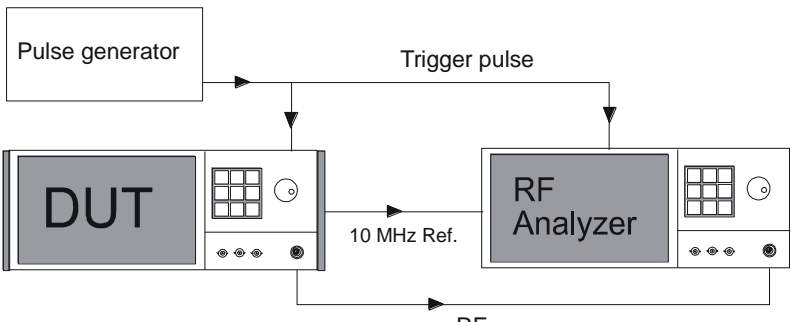
<p>Test equipment</p>	<ul style="list-style-type: none"> - Spectrum analyzer (Table 1-1, item 1) - Pulse generator (Table 1-1, item 8)
<p>Test setup</p>	

1.3 Preparation, Recommended Test Frequencies and Levels

To ensure proper conditions for the performance test and prevent setting errors, the instrument must be prepared as follows:

- Allow for a minimum **warm-up time of 30 minutes** at ambient temperature.
- Carry out all **internal adjustments** (see operating manual, chapter 4, section "Internal Adjustment - Setup-System").
- Press **[PRESET]** to establish a defined **initial** state before configuring a new measurement.

The following sections describe the **procedures** for checking the rated values. The **values** are specified in the **data sheet**. Additional uncertainties introduced by the measurement equipment must be taken into account when checking the rated values.

The following table lists the important internal switch point frequencies and the recommended measurement frequencies derived from these frequencies. We recommend measurements at these frequencies unless particular test frequencies are specified. In the following, RF_{max} is the maximal settable RF (depending on installed options).

Table 1-2 Range limits, main test frequencies for CW Mode

Range	Frequency ranges	Additional hardware switching points	Recommended test frequencies
Direct DDS Synthesis	$100 \text{ kHz} \leq f \leq 23.4375 \text{ MHz}$	-	100 kHz; 200 kHz; 1 MHz; 1.01 MHz; 5 MHz; 10 MHz; 15 MHz ,23.4375 MHz
Divider/128	$23.4375 \text{ MHz} < f \leq 46.875 \text{ MHz}$	-	23.438 MHz; 46.875 MHz
Divider /64	$46.875 \text{ MHz} < f \leq 93.75 \text{ MHz}$	66.29 MHz	46.876 MHz; 66.29 MHz; 66.3 MHz; 93.75 MHz
Divider /32	$93.75 \text{ MHz} < f \leq 187.5 \text{ MHz}$	132.58 MHz	93.76 MHz; 132.58 MHz; 132.59 MHz, 187.5 MHz
Divider /16	$187.5 \text{ MHz} < f \leq 375 \text{ MHz}$	265.17 MHz	187.51 MHz; 265.17 MHz; 265.18 MHz; 375 MHz
Divider /8	$375 \text{ MHz} < f \leq 750 \text{ MHz}$	530 MHz	375.01 MHz; 530 MHz; 530.01 MHz; 750 MHz
Divider /4	$750 \text{ MHz} < f \leq 1500 \text{ MHz}$	1060 MHz	750.01 MHz; 1060 MHz; 1060.01 MHz; 1500 MHz
Divider /2	$1500 \text{ MHz} < f \leq 3 \text{ GHz}$	2121 MHz	1500.01 MHz; 2121 MHz; 2121.01 MHz; 2200 MHz; 3000 MHz
Base octave	$3 \text{ GHz} < f \leq 6.375 \text{ GHz}$	4242 MHz, 6 GHz	3000.01 MHz; 3200 MHz; 4242 MHz; 4242.01 MHz; 5 GHz; 6 GHz, 6.375 GHz, 6.5 GHz, 6.51 GHz
Doubler 1	$6.375 \text{ GHz} < f \leq 12.75 \text{ GHz}$	7.0 GHz, 7.2 GHz, 8.9 GHz, 10.7 GHz	6.376 GHz; 7.15 GHz; 7.151 GHz; 7.2 GHz; 7.201 GHz; 8 GHz; 8.9 GHz; 8.901 GHz; 10.7 GHz; 10.701 GHz; 12 GHz; 12.75 GHz
Doubler 2	$12.75 \text{ GHz} < f \leq 20 \text{ GHz}$	15.6 GHz, 18.7 GHz	12.751 GHz; 14.4 GHz, 14.401 GHz, 15.6 GHz, 15.601 GHz, 17.8 GHz, 17.801 GHz, 18.7 GHz, 18.701 GHz, 19.2 GHz , 20 GHz
Doubler 3	$20 \text{ GHz} < f \leq 40 \text{ GHz}$	25.7 GHz, 30 GHz, 33.7 GHz	20.001 GHz, 25.5 GHz, 25.501 GHz, 25.7 GHz, 25.701 GHz, 28.8 GHz , 28.801 GHz , 30 GHz, 30.001 GHz, 31.2 GHz, 31.201 GHz, 33.7 GHz, 33.701 GHz, 35.6 GHz, 35.601 GHz 37.4 GHz, 37.401 GHz, 40 GHz
Additional test frequencies for hardware options			
Option SMB-B25	$100 \text{ kHz} < f < 20 \text{ GHz}$	150 MHz, 2.9 GHz	150 MHz, 150.1 MHz 2900 MHz, 2901 MHz
Option SMB-B26	$100 \text{ kHz} < f < 40 \text{ GHz}$	150 MHz, 2.9 GHz	150 MHz, 150.1 MHz 2900 MHz, 2901 MHz 29 GHz, 29.001 GHz

Range	Frequency ranges	Additional hardware switching points	Recommended test frequencies
Option SMB-B31	100 kHz < f < 20 GHz	2.9 GHz	2900 MHz, 2901 MHz
Option SMB-B32	100 kHz < f < 40 GHz	2.9 GHz, 29 GHz	2900 MHz, 2901 MHz 29 GHz, 29.001 GHz

RF_{max} is the maximum output frequency of the instrument according to its frequency option (1.1 GHz, 2.2 GHz, 3.2 GHz, 6 GHz, 12.75 GHz, 20 GHz or 40 GHz).

For **high-resolution measurements** in the entire frequency range, a logarithmic frequency grid in 1-2-5 sequence is recommended up to 50 MHz; above this value, linear 50 MHz steps should be used up to the upper limit frequency.

The recommended **test levels** are at the upper and lower switching threshold of the attenuator. The electronic attenuator of the DUT is switched depending on frequency, modulation parameters and level according to an internal stored table in approximately 5 dB steps. The switching thresholds can be detected under **Attenuator fixed range** in the **Level** menu. After setting all other parameters, the threshold level can be detected by level variation. The level at which the attenuator fixed range changes is the threshold. By measuring at the last level setting of one range and the first level setting of the next range, the internal setting range borders are used. In the following, P_{min} is the lowest level before switching the attenuator, and P_{max} the highest.

1.4 Test Procedures

1.4.1 Reference Frequency

1.4.1.1 Output of Internal Reference

Important: Allow the DUT to warm up for at least 2 hours before the measurement.

Test equipment	- Frequency counter ((Table 1-1 , item 1))
Test setup	➤ Connect a calibrated frequency counter to the REF OUT output (on rear panel).
Measurement	➤ Measure the frequency. ⇒ The frequency deviation must not exceed the sum of deviations resulting from the frequency error in the rated temperature range and from aging.

1.4.1.2 Input for External Reference

Test equipment	- Frequency counter ((Table 1-1 , item 1)) - Signal generator (Table 1-1 , item 15)
Test method	The external reference input frequency of the DUT is varied according to the data sheet and the RF output signal frequency is controlled with a frequency counter to follow this variation.

Preparation of measurement	<ul style="list-style-type: none"> ➤ Connect the signal generator RF output to the REF IN input for the external reference (on rear panel) of the DUT. Connect a calibrated frequency counter to the RF output. Synchronize the signal generator and the frequency counter. ➤ Setting on DUT: <ul style="list-style-type: none"> - RF on - Level: 0 dBm (suitable level for the frequency counter) - Frequency: 1 GHz - Setup ⇨ Reference Oscillator ⇨ Source: External ➤ Setting on signal generator: <ul style="list-style-type: none"> - RF on - Level: 0 dBm 												
Measurement	<ul style="list-style-type: none"> ➤ Set the signal generator frequency to 9.99997 MHz and 10.00003 MHz. Measure the output frequency of the DUT. <table border="1" data-bbox="667 790 1313 853" style="margin: 10px auto;"> <tr> <td>Signal generator frequency</td> <td>9.99997 MHz</td> <td>10.00003 MHz</td> </tr> <tr> <td>DUT frequency</td> <td>999.997 MHz</td> <td>1000.003 MHz</td> </tr> </table> ➤ Setting on DUT: <ul style="list-style-type: none"> - External Reference Frequency: 5 MHz ➤ Set the signal generator frequency to 4.999985 MHz and 5.000015 MHz. Measure the output frequency of the DUT. <table border="1" data-bbox="667 1048 1313 1111" style="margin: 10px auto;"> <tr> <td>Signal generator frequency</td> <td>4.999985 MHz</td> <td>5.000015 MHz</td> </tr> <tr> <td>DUT frequency</td> <td>99.9985 MHz</td> <td>100.0015 MHz</td> </tr> </table> <p style="margin-top: 20px;">There must be no relative frequency error and no error message in the display of the DUT.</p>	Signal generator frequency	9.99997 MHz	10.00003 MHz	DUT frequency	999.997 MHz	1000.003 MHz	Signal generator frequency	4.999985 MHz	5.000015 MHz	DUT frequency	99.9985 MHz	100.0015 MHz
Signal generator frequency	9.99997 MHz	10.00003 MHz											
DUT frequency	999.997 MHz	1000.003 MHz											
Signal generator frequency	4.999985 MHz	5.000015 MHz											
DUT frequency	99.9985 MHz	100.0015 MHz											

1.4.2 Frequency

1.4.2.1 Frequency Setting

Test equipment	
Test method	The frequency setting is checked by running the internal synthesizer adjustments to check the frequency overlap of the VCOs
Measurement	<ul style="list-style-type: none"> ➤ Run: Setup ⇨ Internal Adjustments ⇨ Adjust Synthesis There must be no error message.

1.4.2.2 Setting Time

Test assembly	See section " Test Assembly for Setting Time ", page 1.5. For measuring after IEC/IEEE bus delimiter the EOI-line of the IEC/IEEE bus is used as trigger signal instead of the pulse generator.
Test method	The spectrum analyzer operates as an FM demodulator. A controller transmits the start and the stop frequency via the IEC/IEEE bus. The analyzer is triggered by the positive edge on the EOI line of the IEC/IEEE bus or the trigger pulse in list mode. At switch over from start to stop frequency, the settling procedure is displayed on the screen of the analyzer.
Preparation of measurement	<ul style="list-style-type: none"> ➤ Synchronize the reference frequencies of the DUT and the analyzer. ➤ Make IEC/IEEE bus and RF connections. ➤ Connect spectrum analyzers trigger connector to EOI line (pin 5) of IEC/IEEE bus. ➤ Settings on DUT: <ul style="list-style-type: none"> - Frequency: start frequency unmodulated, - Level: 0 dBm ➤ Settings on spectrum analyzer: <ul style="list-style-type: none"> - AMPT/REF LEVEL 0 dBm - FREQ/CENTER/STOP FREQUENCY - FM DEMOD ON - DEMOD BW 50 kHz - RANGE /DEVIATION PER DIV 200 Hz - MEAS TIME 10 ms - TRIGGER EXTERN - External triggering by positive edge at 1.4 V.
Measurement	<ul style="list-style-type: none"> ➤ Settings on analyzer: - Set the analyzer to the stop frequency ➤ Set the DUT to the start frequency f_{start} ➤ Send the stop frequency f_{stop} from the controller to the DUT. <ul style="list-style-type: none"> ⇒ The externally triggered analyzer displays the settling curve. The setting time is defined as the time from which on the frequency deviation from the stop frequency is less than the specified deviation in the data sheet. ➤ Repeat the measurement with ALC state Off: <ul style="list-style-type: none"> ⇒ RF ⇒ Automatic Level Control ⇒ State ⇒ OFF (Sample & Hold)

Measurements in List mode	<ul style="list-style-type: none">➤ Connect a trigger source (digital voltage levels: $U1 < 0.8\text{ V}$ and $U2 > 2\text{ V}$) to the INSTR TRIG connector of DUT and analyzer. The pulse generator can be used as trigger source for example.➤ Settings on DUT:<ul style="list-style-type: none">- In the List mode menu, generate a list containing the two test frequencies f_{start} and f_{stop} with a level of 0 dBm each.- Set operating mode to External Step.➤ Settings on spectrum analyzer:<ul style="list-style-type: none">- Set DEMOD BW to 200 kHz- Set MEAS TIME to 2 ms➤ Toggle the output voltage of the trigger source. (Settings on pulse generator: single shot)➤ With each rising edge from the trigger source the frequency toggles between f_{start} and f_{stop}.⇨ The externally triggered analyzer displays the settling curve. The setting time is defined as the time when the frequency deviation from the stop frequency is less than the specified deviation in the data sheet.➤ For instruments with option B25/B26 (Low Harmonic Filter): Repeat measurement with Low Harmonic Filter State On
---------------------------	--

Recommended test frequencies

f_{start}	f_{stop}	Deviation
23.4 MHz	1100 MHz	± 110 Hz
1100 MHz	23.4 MHz	± 20 Hz
46.8 MHz	46.9 MHz	± 20 Hz
46.9 MHz	46.8 MHz	± 20 Hz
93.7 MHz	93.8 MHz	± 20 Hz
93.8 MHz	93.7 MHz	± 20 Hz
187.4 MHz	187.6 MHz	± 20 Hz
187.6 MHz	187.4 MHz	± 20 Hz
374.9 MHz	375.1 MHz	± 37.5 Hz
375.1 MHz	374.9 MHz	± 37.5 Hz
749.9 MHz	750.1 MHz	± 75 Hz
750.1 MHz	749.9 MHz	± 75 Hz
1499.9 MHz	1500.1 MHz	± 150 Hz
1500.1 MHz	1499.9 MHz	± 150 Hz
2999.9 MHz	3000.1 MHz	± 300 Hz
3000.1 MHz	2999.9 MHz	± 300 Hz
3000.1 MHz	6000 MHz	± 600 Hz
6000 MHz	3000.1 MHz	± 300 Hz
6375 MHz	6375.1 MHz	± 637 Hz
6375.1 MHz	6375 MHz	± 637 Hz
7150 MHz	7150.1 MHz	± 715 Hz
7150.1 MHz	7150 MHz	± 715 Hz
8900 MHz	10700 MHz	± 1070 Hz
10700 MHz	8900 MHz	± 890 Hz
12750 MHz	12750.1 MHz	± 1275 Hz
12750.1 MHz	12750 MHz	± 1275 Hz
15600 MHz	18700 MHz	± 1870 Hz
18700 MHz	15600 MHz	± 1560 Hz
12750.1 MHz	20000 MHz	± 2000 Hz
20000 MHz	12750.1 MHz	± 1275 Hz
20000.1 MHz	40000 MHz	± 4000 Hz
40000 MHz	20000.1 MHz	± 2000 Hz
25700 MHz	33700 MHz	± 3370 Hz
33700 MHz	25700 MHz	± 2570 Hz
25701 MHz	40000 MHz	± 4000 Hz
40000 MHz	25700 MHz	± 2570 Hz

- With Low Harmonic Filter State On perform test only with start- and stop frequencies above 23.4375 MHz
- $f_{\text{start}} = 1100$ MHz to $f_{\text{stop}} = 23,4$ MHz is executed in List Mode only

Example of Measurement:

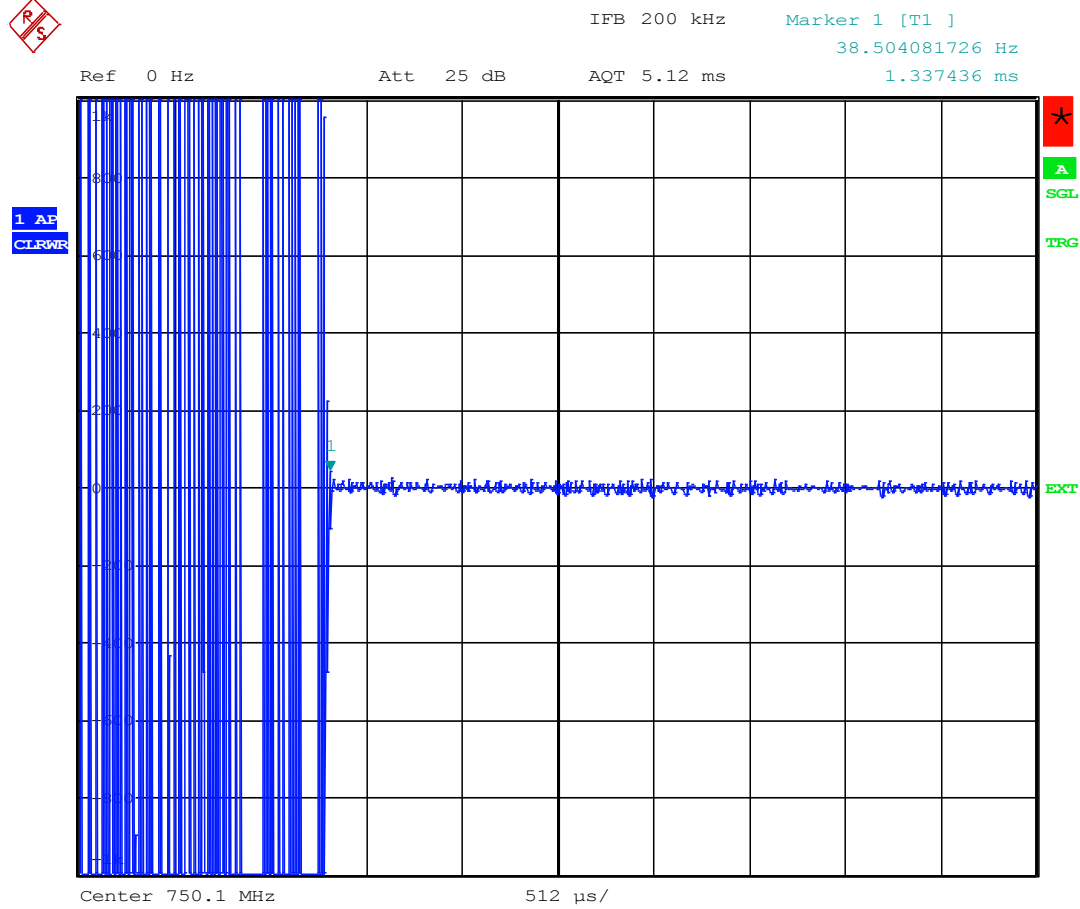

Date: 14.FEB.2008 18:58:23

The marker is set to the time when the trace enters the specified interval of 750.1 MHz ± 75 Hz. The setting time is 1.34 ms.

1.4.3 Spectral Purity

1.4.3.1 Harmonics

Test equipment	Spectrum analyzer (Table 1-1 , item 1)
Test setup	<ul style="list-style-type: none"> ➤ Connect the spectrum analyzer to the RF output of the DUT. ➤ Synchronize the reference frequencies of analyzer and DUT.
Measurement	<ul style="list-style-type: none"> ➤ Settings on analyzer: Reference level = 20 dBm, 10 dB/div. Span 0 Hz, Resolution bandwidth 10 kHz ➤ Settings on DUT: <ul style="list-style-type: none"> - Frequency: test frequencies, unmodulated - Level: test levels ➤ First measure the level of the fundamental P_f at the test frequency f as a reference. Then measure the signal levels P_{2f} and P_{3f} at twice and three times the carrier frequency f. <ul style="list-style-type: none"> ⇒ The harmonic spacing is the measured harmonic level referred to the fundamental: $HD2 = P_f - P_{2f}$ $HD3 = P_f - P_{3f}$ (in dBc = referred to the carrier) ➤ For instruments with option B25/B26 (Low Harmonic Filter) repeat measurement with following Low Harmonic Filter settings Mode: Manual State: On ⇒ Verify the attenuator settings of the spectrum analyzer for a optimum between signal to noise ratio and IP2 performance. If possible, activate the YIG preselection filter of the analyzer, in order to suppress the fundamental when measuring the level of the harmonics.
Recommended test frequencies and levels	<p>Test frequencies: see Table 1-2 for $f \geq 1$ MHz</p> <p>For instruments with option B25/B26 (Low Harmonic Filter) with Low Harmonic Filter State On, Test Frequencies: 150 MHz to 3 GHz in 10 MHz Steps 3 GHz to 15 GHz in 50 MHz Steps 15 GHz to 20 GHz in 100 MHz Steps</p> <p>Test level: Maximum specified level for harmonic performance or maximum specified output power, whichever is lower</p>

1.4.3.2 Subharmonics

Test equipment and setup	Same as for <i>Harmonics</i> .
Test setup	Same as for <i>Harmonics</i> .
Measurement	<ul style="list-style-type: none"> ➤ Measure the level of the fundamental signal. ➤ Measure the level of the subharmonic signal The subharmonic signal can be found at the following frequencies: <ul style="list-style-type: none"> SMB-B112(L): test frequency > 6.375 GHz → 0.5 * test frequency → 1.5 * test frequency SMB-B120(L): test frequency > 6.375 GHz → 0.5 * test frequency → 1.5 * test frequency test frequency > 12.75 GHz → 0.75 * test frequency → 1.25 * test frequency SMB-B131: SMB-B140(L): SMB-B140N: test frequency > 6.375 GHz → 0.5 * test frequency → 1.5 * test frequency test frequency > 12.75 GHz → 0.75 * test frequency → 1.25 * test frequency test frequency > 25.5 GHz → 0.875 * test frequency → 1.125 * test frequency <p>⇒ The subharmonic spacing is the measured level of the subharmonic signal referred to the fundamental (dBc = referred to the carrier).</p>
Recommended test frequencies and levels	<p>6375.1 MHz to Fmax in 50 MHz steps SMB-B112L/B120L/B140L: Level: 0 dBm SMB-B112: 13 dBm SMB-B120/B140: Max. Specified Level</p>

1.4.3.3 Nonharmonics

Test equipment	Same as for harmonics
Test setup	Same as for harmonics
Measurement	<ul style="list-style-type: none"> ➤ Setting on analyzer: Reference level = 0 dBm, 10 dB/div. Span 50 Hz, Resolution bandwidth 10 Hz ➤ Setting on DUT Level = 0 dBm ➤ First the carrier level P_f is measured at the test frequency f as reference and then the signal level P_{search} is measured at the analyzer search frequency. ⇒ The nonharmonic spacing D is the measured level referred to the reference level: $D = P_f - P_{\text{search}}$ (in dBc = referred to the carrier)
	<p>Note: <i>Some of the nonharmonics suppression values measured might be outside the analyzer specifications. In case of doubt, repeat the measurement with a 3 dB attenuator at the analyzer input. If the nonharmonic spacing changes the nonharmonic is due to the analyzer.</i></p> <p>Alternative: <i>Check with a second source with differing synthesizer architecture (not a R&S SMB)</i></p>

Recommended settings and search frequencies:

DUT Frequency / MHz	Offset frequency / kHz	Analyzer search frequency / MHz
13	-4000	9
13	9000	22
17	-2000	15
21	79000	100
21	879000	900
22	-12000	10
23.4375	-17.1875	6.25
23.4375	6250	29.6875
511.2	192	511.392
1050.1	57.14	1050.15714
1100.01	10	1100.02
2045	133.329	2045.133329
4086	720	4086.72
4289.8	3629.75	4293.42975
4521.6	751.807	4522.351807
4745	57.47	4745.05747
5180	4473.684	5184.473684
6274	121.74	6274.12174
8172	720	8172.72
8579.6	3629.75	8583.22975
9043.2	751.807	9043.951807
9490	57.47	9490.05747
10360	4473.684	10364.473684
16344	720	16344.7200
17159.2	3629.75	17162.8298
18086.4	751.807	18087.1518
18980	57.47	18980.0575
20720	4473.684	20724.4737
32688	720	32688.7200
34318.4	3629.75	34322.0298
36172.8	751.807	36173.5518
37960	57.47	37960.0575

1.4.3.4 Non-systematic nonharmonics

Measurement	<ul style="list-style-type: none"> ➤ Settings on DUT: <ul style="list-style-type: none"> - Test frequencies: 34 MHz, 65.9 MHz, 100 MHz, 143.9 MHz, 264.8 MHz, 529.9 MHz, 1059.9 MHz, 2120.9 MHz, 3000 MHz, 4241.9 MHz, 8483.3 MHz, 10 GHz, 12.75 GHz, 12.751 GHz, 20 GHz, 39.95 GHz - Test level 0 dBm unmodulated ➤ Recommended settings on analyzer: <ul style="list-style-type: none"> - Max peak detector - Filter Type: FFT - Ref-Level 0 dBm ➤ <ul style="list-style-type: none"> - Set analyzer center frequency to the test frequency, span to 40 MHz and resolution bandwidth to 2 kHz - Measure carrier level P - all signals other than the carrier must be below P – 70 dB - Set analyzer span to 100 kHz and resolution bandwidth to 200 Hz - all signals other than the carrier must be below P – 70 dB
	<p>Note: <i>Some of the nonharmonics suppression values to be measured might be outside analyzer specifications. In case of doubt, repeat the measurement with a 3 dB attenuator pad at the analyzer input. If the nonharmonics suppression changes the nonharmonics are due to the analyzer. Because of the bell-shaped noise of the analyzer near the carrier, smaller resolution bandwidths may have to be used. To exclude amplitude independent nonharmonics of the analyzer, use a second generator with different synthesis architecture.</i></p>

1.4.3.5 Wideband Noise

Test assembly	Connect spectrum analyzer to RF socket of the DUT.
Test method	<p>The carrier power is measured first. Then the center frequency of the analyzer is increased by the offset frequency and the noise power in a small bandwidth is measured. The difference of the carrier power and the noise power in 1 Hz bandwidth, which is calculated from the measurement, is defined as wideband noise. Because wideband noise degrades with lower electronic levels in front of the output step attenuator the output level of the generator has to be set to the lowest level before switching the step attenuator.</p>

<p>Measurement</p>	<ul style="list-style-type: none"> ➤ Settings on DUT: <ul style="list-style-type: none"> - frequency: test frequency - level: test level P_{Test} ➤ Settings on analyzer: <ul style="list-style-type: none"> - center: test frequency - reference level $P_{Test} + 1$ dB - Attenuator $D_{min} = P_{Test} - P_{1dB} + 5dB \Rightarrow$ round to next larger available attenuation of the analyzer (P_{1dB} = analyzer P1dB level at test frequency) - span 110 kHz - Detector RMS - Sweep Time Manual 1 s - switch on channel power measurement with 100 kHz bandwidth ➤ Determine the channel power with the center frequency of the analyzer set to the test frequency and note it down as P_{ref}. ➤ Increase the analyzer center frequency by offset frequency (see below) ➤ Inhibit the switching of the attenuator with AMPT RF ATTEN MANUAL without entering a value so that the input mixer is not overdriven. ➤ Lower the reference level of the analyzer by 20 dB, read the channel power P_{Noise}. ➤ Minimize the output level on the DUT by means of RF OFF, read the channel power $P_{Analyzer}$. (analyzer noise floor)
<p>Evaluation</p>	<ul style="list-style-type: none"> ➤ If the analyzer noise $P_{Analyzer}$ is more than 0.41 dB below the measured noise P_{Noise} ($P_{Noise} - P_{Analyzer} > 0.41$ dB), the inherent noise power of the analyzer can be subtracted: $Wideband_Noise = -P_{ref} + 10 \cdot \log_{10}(10^{P_{Noise}/10} - 10^{P_{Analyzer}/10}) - 50dB$ ➤ If the analyzer noise $P_{Analyzer}$ is less than 0.41 dB below the measured noise P_{Noise} ($P_{Noise} - P_{Analyzer} < 0.41$ dB), the analyzer resolution is not sufficient for a precise measurement. The true result is in such case certainly more than 10 dB below the measured value. The result is at least: $Wideband_Noise = -P_{ref} + P_{Noise} - 50dB - 10dB$ <p>\Rightarrow The difference between the (possibly corrected) power P_{Noise} in dBm and the power P_{ref} in dBm is the broadband noise floor in dBc.</p>
<p>Recommended test and offset frequencies</p>	<ul style="list-style-type: none"> ➤ test frequencies see Table 1-2 for $f \geq 15$ MHz ➤ additional test frequency: 1.9 GHz ➤ offset frequencies 9.8 MHz for test frequency ≤ 6.375 GHz 29.9 MHz for test frequency > 6.375 GHz

Recommended test level for instruments equipped with R&S SMB-B112L	- Level: $P_{\text{Test}} = 10 \text{ dBm}$
Recommended test level for instruments equipped with R&S SMB-B112	- Level: $P_{\text{Test}} = 10 \text{ dBm}$ - determine Att-fixed range upper Level P_{upper} : - $\Rightarrow \text{RF} \Rightarrow \text{Level} \Rightarrow \text{Att fixed range} \Rightarrow \text{upper}$ - if $P_{\text{upper}} < 15 \text{ dBm}$ set level to $P_{\text{Test}} = P_{\text{upper}} + 0.1 \text{ dB}$ - if $P_{\text{upper}} \geq 15 \text{ dBm}$ set level to $P_{\text{Test}} = +10 \text{ dBm}$
Recommended test level for instruments equipped with R&S SMB-B120/B140/120L/B140L	- Level: $P_{\text{Test}} = 10 \text{ dBm}$ or maximum specified output level (whichever is lower)

1.4.3.6 SSB Phase Noise

The SSB phase noise of the DUT can be measured direct if a Signal Source Analyzer (item 1) is available. An R&S FSUP or any other analyzer with phase noise option is suitable if its own phase noise is at least 6 dB less than the guaranteed DUT Phase noise in the data sheet. Measurement: Set the Level of the DUT to 10 dBm and measure the phase noise at 20 kHz offset with the analyzer in phase noise mode.

If no suited signal source analyzer is available, the Phase noise can be measured with the aid of a second generator and a mixer:

Test assembly	See section " Test Assembly for SSB Phase Noise and Jitter ", page 1.4.
Test method	The two generators are set to the test frequency and synchronized with a phase offset of 90° (phase quadrature). Mixing to 0 Hz suppresses the RF carrier. Due to the phase quadrature, the mixer supplies a voltage representing the phase difference between the input signals. This voltage is measured with the spectrum analyzer.

<p>Measurement</p>	<ul style="list-style-type: none"> ➤ Set the levels of the two generators in accordance with the specifications of the mixer used. (For the MITEQ-DB0118 mixer set the LO-level to +10 dBm and the RF-level to 0 dBm.) ➤ Settings of the DUT: <ul style="list-style-type: none"> - Level = 10 dBm - PM int - PM deviation 0.01 rad - Modulation frequency 19 kHz ➤ Settings on the analyzer: <ul style="list-style-type: none"> - Center frequency 19.5 kHz - Span 2 kHz - Input coupling DC - Attenuator manual 0 dB - average on, count = 10 - average mode: linear/ power - Filter Type: FFT - Resolution Bandwidth 10 Hz - set marker to 19 kHz. - set delta marker to 20 kHz
	<ul style="list-style-type: none"> ➤ Adjust the phase of the DUT for phase quadrature: Set the Delta Phase in the Frequency/Phase menu for maximum marker readout at 19 kHz in the Delta Phase range of 0 ° to 180 °. Note down the relative Delta marker level D. ➤ Calculate the SSB phase noise in dbc/Hz: <ul style="list-style-type: none"> - The Delta Marker measures the noise in 10 Hz bandwidth. The power in 1 Hz bandwidth is one tenth of this power: $\log_{10}(10)$ - The PM with a modulation rate of 0.01 rad is equivalent to a phase noise of -46 dBc. - The phase noises of the two generators add together: - 3 dB if they are of the same type. If the reference generator is of the same type as the DUT: $PN = D - 10 * \log_{10}(10) - 46 \text{ dB} - 3 \text{ dB}$ PN = D - 59 dB If the phase noise of the reference generator is at least 10 dB better than the phase noise of the DUT: $PN = D - \log_{10}(10) - 46 \text{ dB}$ PN = D - 56 dB
<p>Recommended test frequencies.</p>	<ul style="list-style-type: none"> ➤ 100 MHz, 1 GHz, 2 GHz, 3 GHz, 4 GHz, 6 GHz, 10 GHz, 20 GHz, 40 GHz

Example: Two R&S SMB measured against each other

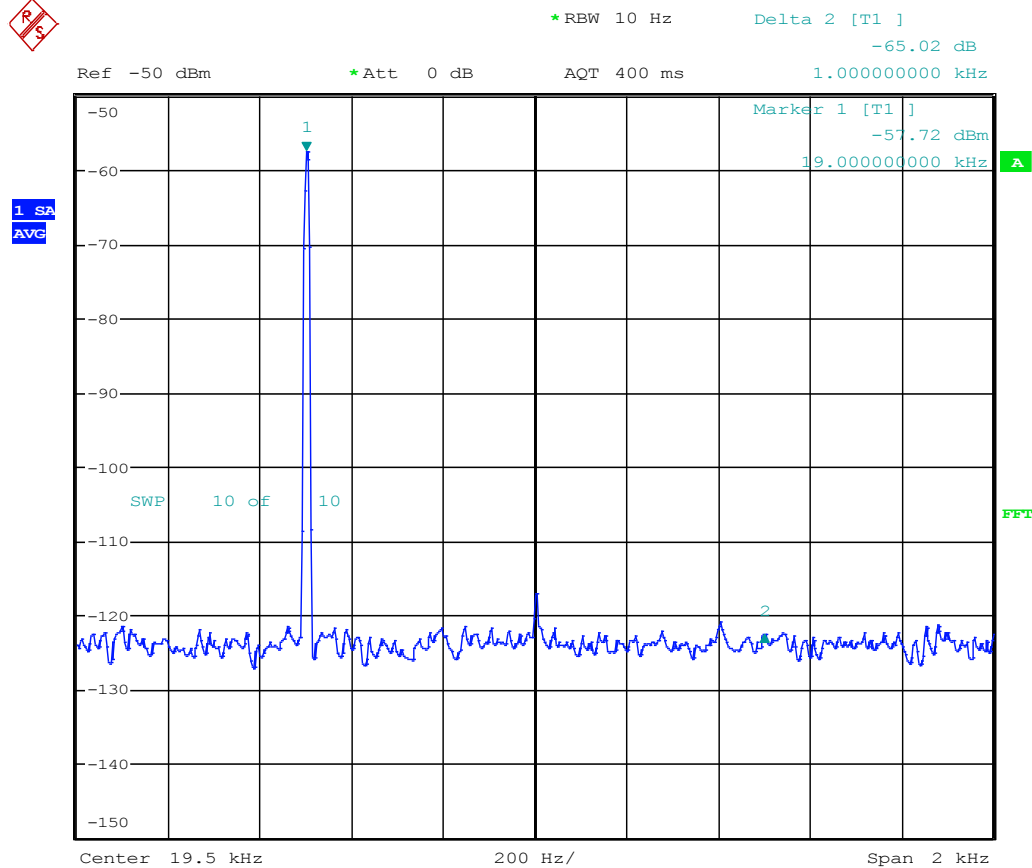

Date: 22.FEB.2008 16:32:46

PN = -65.02 dBc -59 dB = 124.02 dBc/ Hz

1.4.3.7 Residual FM

Test assembly	Connect spectrum analyzer to RF socket of the DUT.
Test method	The FM demodulator of the analyzer is used to FM-demodulate the CW signal of the DUT. By setting the AF-low-pass and high-pass-filters the RMS value in the desired bandwidth can be measured. The value displayed is the sum of the analyzer residual FM and the DUT residual FM. Because they are uncorrelated, the displayed result is worse than residual RMS of the DUT alone. Therefore, if the sum is in tolerance according to the data sheet the DUT is also in tolerance.

<p>Measurement</p>	<ul style="list-style-type: none"> ➤ Settings on DUT: <ul style="list-style-type: none"> - frequency: 1 GHz - Level: 0 dBm ➤ Settings on analyzer: <ul style="list-style-type: none"> - CENTER: 1 GHz - REFERENCE LEVEL: 1 dBm - FM DEMOD - FM DEMOD ⇨ MEAS TIME: 100 ms - FM DEMOD ⇨ DEMOD BW: 200 kHz - FM DEMOD ⇨ AF-FILTER ⇨ HIGH PASS AF FILTER: 300 Hz - FM DEMOD ⇨ AF-FILTER ⇨ LOW PASS AF FILTER: 3 kHz ➤ The Residual FM in the frequency range 300 Hz – 3 kHz is the RMS value displayed. ➤ Repeat the measurement with setting the HIGH PASS AF FILTER: to 20 Hz and the LOW PASS AF FILTER to 23 kHz.
--------------------	--

Example:

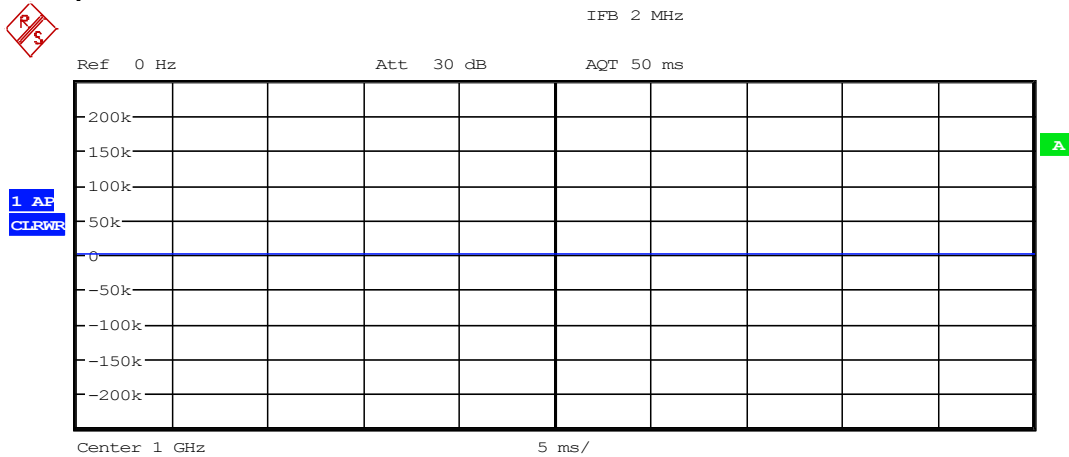

Frequency Modulation Summary

Coupling	DC	Carrier Offset	45.639 Hz
Deviation	+peak 12.93 Hz	Carrier Power	-0.91 dBm
	-peak -12.41 Hz	Modulation Frequency	--- Hz
	±peak/2 12.67 Hz	Sampling Rate	250 kHz
	RMS 3.465 Hz	Record Length	12501
		Demod Bandwidth	200 kHz
		AF Filter	HP 20 Hz
			LP 23 kHz

Date: 22.FEB.2008 17:35:25

Residual FM = 3.465 Hz

1.4.3.8 Residual AM

Test assembly	Connect spectrum analyzer to RF socket of the DUT.
Test method	The FM demodulator of the analyzer is used to AM-demodulate the CW signal of the DUT. By setting the AF-low-pass and high-pass-filters the RMS value in the desired bandwidth can be measured. The value displayed is the sum of the analyzer residual AM and the DUT residual AM. Because they are uncorrelated, the displayed result is worse than residual RMS of the DUT alone. Therefore, if the sum is in tolerance according to the data sheet the DUT is also in tolerance.
Measurement	<ul style="list-style-type: none"> ➤ Settings on DUT: <ul style="list-style-type: none"> - frequency: 1 GHz - Level: 8 dBm ➤ Settings on analyzer: <ul style="list-style-type: none"> - CENTER: test frequency - REFERENCE LEVEL: 10 dBm - AMPT ⇒ RF ATTEN MANUAL: 10 dB - FM DEMOD - FM DEMOD ⇒ RESULT DISPLAY ⇒ AM - FM DEMOD ⇒ MEAS TIME: 100 ms - FM DEMOD ⇒ DEMOD BW: 200 kHz - FM DEMOD ⇒ AF-FILTER ⇒ HIGH PASS AF FILTER: 20 Hz - FM DEMOD ⇒ AF-FILTER ⇒ LOW PASS AF FILTER: 20 kHz ➤ The Residual AM in the frequency range 20 Hz – 23 kHz is the RMS value displayed.
Test frequencies	5 MHz, 450 MHz, 1 GHz, 2.2 GHz, 3.2 GHz, 4.5 GHz, 6 GHz, 7 GHz, 10 GHz, 12.75 GHz, 12.7501 GHz, 16 GHz, 16.0001 GHz, 20 GHz, 20.0001 GHz, 40 GHz

Example:

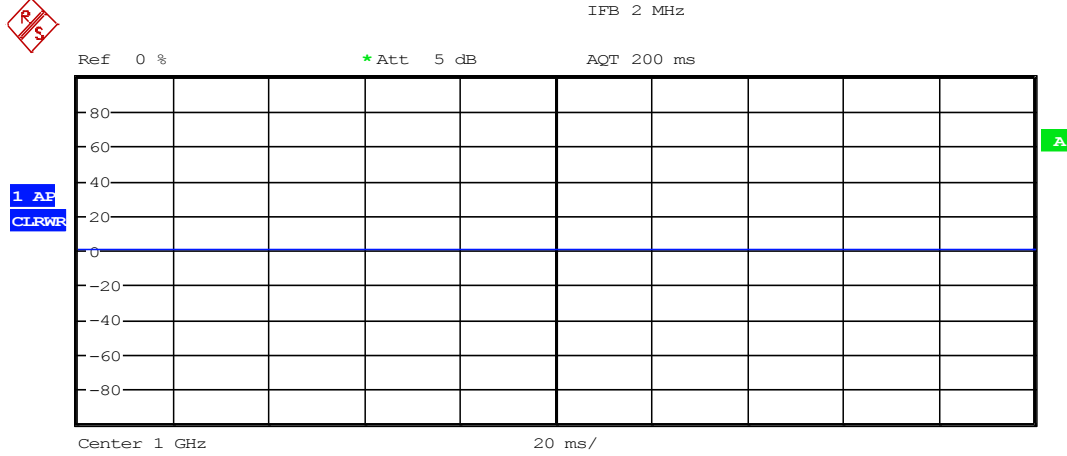

Amplitude Modulation Summary

Modulation Depth	0.022 %	Carrier Power	-0.87 dBm
Modulation +peak	0.022 %	Modulation Frequency	--- Hz
-peak	-0.023 %	Sampling Rate	250 kHz
±peak/2	0.022 %	Record Length	50001
RMS	0.005 %	Demod Bandwidth	200 kHz
		AF Filter	HP 20 Hz LP 23 kHz

Date: 25.FEB.2008 16:33:44

Residual AM = 0.005 %

1.4.4 Level Data

1.4.4.1 Level Uncertainty

Test method	The level uncertainty is measured in two steps. First, the frequency response is measured at a fixed level with high frequency resolution. Then the level dependant uncertainty is measured at fixed frequencies over the specified range.
Test equipment	- Power meter (<i>Table 1-1</i> , item 5) or - Spectrum analyzer (<i>Table 1-1</i> , item 1)

Test method for levels in measurement range of power meter

Test setup	Connect power meter to RF output socket.
Measurement	<ul style="list-style-type: none"> ➤ Setting on DUT: <ul style="list-style-type: none"> - Levels : test level - ALC Mode: AUTO, and ALC Table ➤ Measure the level $P_{absolute}$ at the recommended test frequencies up to RF_{max}. ➤ For instruments with option B25/B26 (Low Harmonic Filter): Repeat measurement in ALC Mode: AUTO with Low Harmonic Filter State On <p>⇒ The level error is the deviation of the measured level from the set value.</p>
Recommended test levels for frequency response measurement	<ul style="list-style-type: none"> ➤ ALC Mode AUTO and S&H Option R&S SMB-B112/B120/B140: maximum specified level, 5 dBm Option R&S SMB-B112L/B120L/B140L: maximum specified level, minimum specified level Option R&S SMB-B25/B26: Test with Low Harmonic Filter State On 10dBm
Recommended test frequencies for the level frequency response measurement	<p>200.01 kHz, 500 kHz, 1 MHz, 1.01 MHz, 5 MHz, 7 MHz, 10 MHz, 23.4375 MHz, 23.4376 MHz</p> <p>25 MHz to 95 MHz in 10 MHz steps for measurement with ALC Mode AUTO at max. spec.level 112.5 MHz to fmax in 25 MHz steps otherwise 112.5 MHz to fmax in 100 MHz steps</p> <p>Additional test points at 12.75 GHz+1Hz and 20 GHz+1 Hz</p> <p>Option R&S SMB-B25/B26: Test with Low Harmonic Filter State On: test frequency > 150 MHz</p>
Measurement of level dependent uncertainty for instruments with no step attenuator (instruments equipped with R&S SMB-B112L/B120L/B140L)	
Recommended test levels	-5 dBm to 18 dBm in 2 dB steps
Recommended test frequencies for instruments equipped with R&S SMB-B112L	201 kHz, 12.5 MHz, 512.5 MHz, 1087.5 MHz, 2187.5 MHz, 3187.5 MHz, 4012.5 MHz, 5012.5 MHz, 5987.5 MHz, 7012.5 MHz, 8012.5 MHz, 9012.5 MHz, 10012.5 MHz, 11012.5 MHz, 12012.5 MHz, 12737.5 MHz,
Recommended test frequencies for instruments equipped with R&S SMB-B120L/B140L	201 kHz, 12.5 MHz, 512.5 MHz, 1087.5 MHz, 2187.5 MHz, 3000 MHz, 3125 MHz, 5125 MHz, 7125 MHz, 9125 MHz, 10050 MHz, 12050 MHz, 15550 MHz, 16150 MHz, 18050 MHz, 20000 MHz, 20050 MHz, 24250 MHz, 27550 MHz, 30250 MHz, 32250 MHz, 34250 MHz, 35250 MHz, 36250 MHz, 37250 MHz, 38150 MHz, 39150 MHz, 39950 MHz

Test method for measurement of level dependent uncertainty at low levels for instruments equipped with step attenuator (option R&S SMB-B112/B120/B140)

<p>Test principle</p>	<p>Low levels can only be measured using a frequency selective measurement instrument. Spectrum analyzers with digital IF are best suited for this measurement due to their low linearity error. The absolute accuracy of these analyzers is not sufficient for this measurement. So a relative measurement referred to the measurements performed with the power meter is used to increase the accuracy of the measurement.</p> <p>Only by switching the input attenuator and preamplifier (when available) of the analyzer the needed dynamic range of more than 120 dB can be reached. After switching the analyzer attenuator or preamplifier, a continuity calibration is to be carried out. It is therefore recommended to switch the attenuator not until reaching 50 dB under full scale, since the linearity errors are very small in this range.</p>
<p>Test setup</p>	<ul style="list-style-type: none"> ➤ Connect the spectrum analyzer to the RF output of the DUT with hermetically sealed RF measurement cables.
<p>Measurement</p>	<ul style="list-style-type: none"> ➤ Settings on DUT Frequency recommended test frequencies Level: maximum specified level, unmodulated ➤ Setting on the analyzer Test frequency SPAN 10 Hz FILTER TYPE FFT RES BW 5 Hz set Marker to test frequency Reference level $P_{ref} = +20$ dBm ➤ Read the marker level P_{Marker} and calculate the correction factor $C = P_{absolute} - P_{Marker}$ with $P_{absolute}$ from the measurements performed with the power meter. ➤ Now decrease the DUT level in 5 dB steps and calculate the output power P by adding the Correction factor C to the marker readout. ➤ As soon as the marker level P_{Att1} is lower than $P_{ref} -45$ dB increase the sensitivity of the analyzer by reducing the input attenuation, switching on the internal preamplifier (if available) or by using an external preamplifier and reducing the resolution bandwidth to 1 Hz for levels below -90 dBm. Set the analyzer reference level to $P_{Att1} + 1$ dB. After switching the analyzer sensitivity read out the marker level P_{Att2} and recalculate the Correction factor: $C_{new} = C_{old} + P_{Att1} - P_{Att2}$ ➤ Set the DUT level to RF OFF and measure the noise floor P_{noise} of the analyzer. If the noise floor of the analyzer is less the 20 dB below the measured carrier level, the carrier level must be corrected by the noise floor. $P_{carrier_corrected} = 10 \cdot \log_{10}(10^{P_{carrier}/10} - 10^{P_{noise}/10})$ ➤ Continue the measurement down to -120 dBm in 5 dB steps. ➤ -120 dBm in 5 dB steps.

Recommended test frequencies for instruments equipped with R&S SMB-B112	201 kHz, 512.5 MHz, 1087.5 MHz, 2187.5 MHz, 3187.5 MHz, 4012.5 MHz, 5012.5 MHz, 5987.5 MHz, 7012.5 MHz, 8012.5 MHz, 9012.5 MHz, 10012.5 MHz, 11012.5 MHz, 12012.5 MHz, 12737.5 MHz
Recommended test frequencies for instruments equipped with R&S SMB-B120/B140	201 kHz, 12.5 MHz, 512.5 MHz, 1087.5 MHz, 2187.5 MHz, 3000 MHz, 3125 MHz, 5125 MHz, 7125 MHz, 9125 MHz, 10050 MHz, 12050 MHz, 15550 MHz, 16150 MHz, 18050 MHz, 20000 MHz, 20050 MHz, 24250 MHz, 27550 MHz, 30250 MHz, 32250 MHz, 34250 MHz, 35250 MHz, 36250 MHz, 37250 MHz, 38150 MHz, 39150 MHz, 39950 MHz

1.4.4.2 Output Impedance

Only for instruments equipped with option R&S SMB-B112/B112L

Test assembly	"Test Assembly for Output Impedance (VSWR)" (page 1.5)
Test method	For the VSWR measurement of a source the effect of the level control must be taken into account. For this purpose, an auxiliary generator is used which transmits a wave with a slightly offset carrier frequency into the DUT. The difference frequency has to be within the control bandwidth of the level control. In the case of ideal source impedance, the wave from the auxiliary generator is not reflected by the DUT. In the case of not ideal DUT source impedance, the output wave of the DUT and the reflected wave of the auxiliary generator are superimposed on one another. A directional coupler couples a part of these outgoing superimposed waves to an analyzer. The frequency offset, results in a beat of the superimposed outgoing waves. The VSWR is the ratio between the maximum and minimum amplitude of the beat.

<p>Measurement</p>	<ul style="list-style-type: none"> ➤ Settings on DUT: <ul style="list-style-type: none"> - Level: test level - Frequency: test frequency, unmodulated ➤ Settings on spectrum analyzer: <ul style="list-style-type: none"> - Test frequency, span 0 Hz, test level - Resolution and video bandwidth 10 kHz - Linear level scale - Sweep time 20 ms ➤ Settings on second signal generator: <ul style="list-style-type: none"> - set the frequency to the test frequency – 100 Hz, - set minimum level, unmodulated. ➤ Vary the reference level to bring the line displayed on the screen of the spectrum analyzer approximately into the middle of the screen. Measure the voltage of the signal V_{ref}. ➤ Unscrew the VSWR bridge from the DUT and let the test port open. Increase the level of the second signal generator until the voltage on the analyzer is $V_{ref} \pm 0.5\%$. ➤ Screw the VSWR bridge onto the DUT again. ➤ Measure the maximum voltage V_{max} and minimum voltage V_{min} of the sinusoidal trace. Calculate the VSWR: $VSWR = V_{max}/V_{min}$
<p>Recommended test frequencies</p>	<ul style="list-style-type: none"> ➤ Test frequencies: from 200 kHz every 50 MHz up to RF_{max}.
<p>Recommended test level for instruments equipped with R&S SMB-B112L</p>	<p>0 dBm.</p>
<p>Recommended test level for instruments equipped with R&S SMB-B112</p>	<ul style="list-style-type: none"> ➤ Settings on DUT for test level 1 <ul style="list-style-type: none"> - Frequency: test frequency - Level: Attenuator Settings Mode “AUTO” set level to maximum specified level Attenuator Settings Mode “FIXED” set level to 0 dBm ➤ Settings on DUT for test level 2 <ul style="list-style-type: none"> - set “Attenuator Mode” to AUTO - set level to -10 dBm

1.4.4.3 Setting Time

Test assembly

Connect the spectrum analyzer ([Table 1-1](#), item 1) to the RF connector of the DUT.

Test method

The spectrum analyzer is operated as a fast level meter in zero span. A controller transfers the start and the stop level via the IEC/IEEE bus. The analyzer is triggered by the positive edge on the EOI line of the IEC/IEEE bus. At switch over from start to stop level, the settling procedure is displayed on the screen of the analyzer.

- Preparation of measurement
- Synchronize the reference frequencies of the DUT and the analyzer.
 - Make IEC/IEEE bus and RF connections.
 - Connect spectrum analyzers trigger connector to EOI line (pin 5) of IEC/IEEE bus.
 - Setting on DUT:
 - **Frequency:** test frequency unmodulated,
 - **Level:** start level

- Settings on spectrum analyzer:
 - REFERENCE LEVEL: target level + 3 dB
 - AMPLITUDE LOG RANGE 10 dB
 - RESOLUTION BANDWIDTH 200 kHz
 - VIDEO BANDWIDTH 2 MHz
 - SPAN 0 Hz
 - SWEEP TIME: 10 ms
 - TRIGGER EXTERN
 - External triggering by positive edge at 1.4 V.

- Measurement
- Send the stop level from the controller to the DUT.
 - ⇒ The externally triggered analyzer displays the settling curve. The setting time is defined as the time from which on the level deviation from the final level is less than the specified deviation in the data sheet.
 - Measure the following steps with ALC state AUTO, with ALC state OFF (Sample & Hold) and List mode.
 - Measure the following steps with ALC state AUTO, with ALC state OFF (Sample & Hold) and List mode.

Recommended test frequencies

Frequencies: 1 MHz, 30 MHz, 375 MHz, 1.1 GHz, 2.2 GHz, 3.2 GHz, 6 GHz, 7.15 GHz, 7.151 GHz, 10 GHz, 12.75 GHz, 13 GHz, 16 GHz, 20 GHz, 26 GHz, 30 GHz, 40 GHz

Recommended test level for instruments equipped with R&S SMB-B112L/B120L/B140L

Measure the following steps with ALC state AUTO, with ALC state OFF (Sample & Hold) and List mode.

Start level	Stop level
Minimum specified level	Maximum specified level
Maximum specified level	Minimum specified level

Recommended test level for instruments equipped with R&S SMB-B112

Measure the following steps with ALC state AUTO, with ALC state OFF (Sample & Hold) and List mode

Start level	Stop level
-130 dBm	Maximum specified level
-35 dBm	-5 dBm
-5 dBm	-35 dBm

Recommended test level for instruments equipped with R&S SMB-B120/B140

Measure the following steps with ALC state AUTO

Start level	Stop level
-130 dBm	Maximum specified level

Measure the following steps with ATTENUATOR MODE FIXED ALC state AUTO, with ALC state OFF (Sample & Hold) and List mode

Start level	Stop level
0 dBm	Maximum specified level
Maximum specified level	0 dBm

1.4.5 Internal Modulation Generator

Frequency accuracy

The LF-Generator is integrated into an FPGA clocked with the same reference frequency as the synthesizer. Therefore, the LF frequency has the same accuracy as the RF and has not to be measured.

Distortions

Test equipment	Spectrum analyzer (Table 1-1 , item 1)
Test method	The fundamental and harmonics of the LF-generator are measured with the analyzer. The analyzer calculates the Total Harmonic Distortion with the 'Harmonic Distortion' function.
Test setup	<ul style="list-style-type: none"> ➤ Connect the spectrum analyzer to the LF socket of the DUT through a 150 Ω series resistor. This is necessary, because the LF output can only drive 200 Ω loads with very good harmonic distortion. If the instrument is equipped with a RFBOARD 1406.7207.xx switch the LF Gen output impedance to 600 Ω and omit the 150 Ω series resistor.
Measurement of frequency settings and distortion	<ul style="list-style-type: none"> ➤ Settings on DUT: LF Output menu: LF Gen Voltage 1 V LF Gen Frequency 1 kHz ➤ Settings of the spectrum analyzer: RF INPUT DC AMPT REF LEVEL 10 dBm FREQ CENTER = LF Gen Frequency MEAS ⇒ HARMONIC DISTOR RF ATTEN MANUAL increase by 10 dB ➤ Read the THD ➤ repeat the measurement at the recommended test frequencies by changing the DUT LF Gen Frequency and the analyzer center frequency.
Recommended test frequencies	100 Hz, 300 Hz, 1 kHz, 3kHz, 10 kHz, 30 kHz, 100 kHz

Level Accuracy and Frequency response

Test equipment	AC voltmeter (<i>Table 1-1</i> , item 10)
Test method	The output level of the LF Generator is measured direct with an AC voltmeter.
Test setup	➤ Connect the AC voltmeter to the LF socket of the DUT.
Measurement of Level Accuracy	➤ Settings on DUT: LF Output menu: LF Gen Frequency 1 kHz set LF Output Voltage to recommended levels and measure the output level
Recommended test levels for Level Accuracy	3 mV, 10 mV, 30 mV, 100 mV, 300 mV, 1 V and 3 V
Measurement of Frequency response	➤ Settings on DUT: LF Output menu: LF Output Voltage 1 V set LF Gen Frequency to recommended test frequencies and measure the output level ⇒ Determine the highest and the lowest level V_{max} and V_{min} . The frequency response in dB is defined as: $D = 20 \cdot \log_{10}(V_{max}) - 20 \cdot \log_{10}(V_{min})$
Recommended test frequencies	10 Hz, 1 kHz, 10 kHz, 100 kHz and 1 MHz

Note: *The settling time is a pure computer time and needs therefore not to be measured.*

1.4.6 Amplitude Modulation

1.4.6.1 AM Setting Uncertainty

Test assembly	See section " Standard Test Assembly for Analog Modulations ", page 1.2.
Measurement of accuracy versus modulation depth	<ul style="list-style-type: none"> ➤ Settings on DUT: RF On Frequency 10 GHz Level: test level Amplitude Modulation On AM Source Internal LF Gen Frequency 1 kHz ➤ Settings on analyzer: AMPTD ⇒ REF LEVEL test level + 6 dB , FREQ ⇒ CENTER 10 GHz FM DEMOD, FMDEMOD ON, RESULT DISPLAY ⇒ AM DEMOD BW 50 kHz RANGE ⇒ DEVIATION PER DIV 20 % MEAS TIME 100 ms ➤ Settings on DUT AM Source External, AM Ext Coupling AC, LF Gen Output On, ➤ Set the AM Depth to the recommended modulation depths Connect LF output to MOD EXT input and read the modulation depth $\pm\text{peak}/2$ from the analyzer.
Recommended modulation depths	m = 5 %, 10 %, 20 %, 40 %, 60 %, 80 %
Recommended test level	maximum specified level – 5.8 dB

<p>Measurement of accuracy versus RF</p>	<ul style="list-style-type: none"> ➤ Settings on DUT: RF On Frequency recommended test frequencies Level: 0 dBm Amplitude Modulation On AM Source Internal LF Gen Frequency 1 kHz AM Depth 80 % ➤ Settings on analyzer: AMPTD ⇨ REF LEVEL 6 dBm, FREQ ⇨ CENTER same as DUT FM DEMOD, FMDEMOD ON, RESULT DISPLAY ⇨ AM DEMOD BW 50 kHz RANGE ⇨ DEVIATION PER DIV 20 % MEAS TIME 100 ms ➤ Measure the modulation depth for all recommended test frequencies
<p>Recommended test frequencies</p>	<ul style="list-style-type: none"> ➤ see Table 1-2, $f > 1$ MHz
<p>Recommended test level</p>	<p>Test level = Maximum specified level – 5.1 dB</p>

1.4.6.2 AM Distortion

Test assembly	See section " Standard Test Assembly for Analog Modulations ", page 1.2.
Measurement	<ul style="list-style-type: none"> ➤ Settings on DUT: RF On Level test level Amplitude Modulation menu: LF Gen Frequency 1 kHz Source Internal AM depth 30 % and 80 %. ➤ Settings on R&S FSQ: AMPTD / REF LEVEL 6 dBm, FREQ / CENTER test frequency FM DEMOD, FMDEMODOFF, RESULT DISPLAY ⇒ AM RESULT DISPLAY ⇒ AF SPECTRUM DEMODOFF BW > 7 * f_{mod}, RANGE ⇒ DEVIATION PER DIV 20 % MEAS TIME 0.16 s ➤ Measure the THD for all recommended test frequencies. To convert the displayed THD value in dB to percent calculate: $THD_{pct} = 100 * 10^{(THD_{dB}/20)}$. ➤ Repeat the measurement with AM depth set to 80 %.
Recommended test frequencies	➤ see Table 1-2 , f > 5 MHz
Recommended test level	<p>AM depth = 30 %: Test level = Maximum specified level for AM distortion – 2.3 dB</p> <p>AM depth = 80 %: Test level = Maximum specified level for AM distortion – 5.2 dB</p>

1.4.6.3 AM Frequency Response

Test assembly	See section " Standard Test Assembly for Analog Modulations ", page 1.2.												
Measurement	<ul style="list-style-type: none"> ➤ Settings on DUT: RF On Level test level Amplitude Modulation menu: Source External External Coupling DC AM depth 60 %. ➤ Settings on R&S FSQ: AMPTD / REF LEVEL test level + 6 dB FREQ / CENTER test frequency FM DEMOD, FMDEMODOFF, RESULT DISPLAY ⇒ AM RESULT DISPLAY ⇒ AF SPECTRUM DEMODOFF BW 200 kHz, RANGE ⇒ DEVIATION PER DIV 20 % MEAS TIME ≥ 16/fmod s ➤ Settings on the signal generator: - LF Output ON - LFGen Voltage 1 V (V_{peak}). <ul style="list-style-type: none"> ➤ Set the generator frequency to the frequencies given below and measure the modulation depth in RMS. <table border="1" data-bbox="655 1205 1378 1285" style="margin-left: 40px;"> <tr> <td>Gen. frequency</td> <td>10 Hz</td> <td>100 Hz</td> <td>1 kHz</td> <td>10 kHz</td> <td>50 kHz</td> </tr> <tr> <td>MEAS TIME</td> <td>1.6 s</td> <td>0.2 s</td> <td>0.2 s</td> <td>0.2 s</td> <td>0.2 s</td> </tr> </table> <p>⇒ The modulation frequency response in dB is the difference between the greatest and the smallest modulation depth m_{max} and m_{min}:</p> $m_{max-min} = 20 * \log_{10}(m_{max}) - 20 * \log_{10}(m_{min})$	Gen. frequency	10 Hz	100 Hz	1 kHz	10 kHz	50 kHz	MEAS TIME	1.6 s	0.2 s	0.2 s	0.2 s	0.2 s
Gen. frequency	10 Hz	100 Hz	1 kHz	10 kHz	50 kHz								
MEAS TIME	1.6 s	0.2 s	0.2 s	0.2 s	0.2 s								
Recommended test frequencies	<ul style="list-style-type: none"> ➤ 1.01 MHz, 46.87 MHz, 186.9 MHz, 375.1 MHz 1.1 GHz, 2.2 GHz, 3.2 GHz, 6 GHz, 7.15 GHz, 7.151 GHz, 10 GHz, 12.75 GHz, 13 GHz, 16 GHz, 20 GHz, 26 GHz, 30 GHz, 39.999 GHz 												
	<ul style="list-style-type: none"> ➤ Repeat the measurement at RF = 1 GHz with the setting Amplitude Modulation ⇒ External Coupling AC ➤ Repeat the measurement at RF = 1 GHz with the internal modulation generator with the setting Amplitude Modulation ⇒ Source Internal. 												
Recommended test level	Test level = Maximum specified level – 4.1 dB												

1.4.6.4 Synchronous PhiM with AM

Test assembly	See section " Standard Test Assembly for Analog Modulations ", page 1.2.
Measurement	<ul style="list-style-type: none"> ➤ Settings on DUT: RF On Level test level Amplitude Modulation menu: Source Internal LF Gen Frequency 1 kHz AM depth 30 %. ➤ Settings on spectrum analyzer AMPTD / REF LEVEL 3 dBm, FM DEMOD DEMOD BW 12.5 kHz MEAS TIME 100 ms RESULT DISPLAY ⇔ PM ➤ Measure the resulting phase modulation with peak detection (\pmpeak/2-value).
Recommended test frequencies	➤ see Table 1-2 $f > 1$ MHz
Recommended test level for instruments equipped with R&S SMB-B112L	-2 dBm
Recommended test level for instruments equipped with R&S SMB-B112/B120/B140 /B120L/B140L	Test level = Maximum specified level – 2.3 dB

1.4.7 Frequency Modulation

1.4.7.1 Test Methods

Test assembly	See section " Standard Test Assembly for Analog Modulations ", page 1.2
Test Method "FFT Demodulation (Option FS-K7)"	<ul style="list-style-type: none"> • The FM deviation and distortion are determined by digital signal processing in the spectrum analyzer. ➤ Settings on R&S FSQ: <ul style="list-style-type: none"> AMPTD / REF LEVEL test level, FREQ / CENTER test frequency FMDEMODOFF, <ul style="list-style-type: none"> FMDEMODOFF ON, RESULT DISPLAY / FM resp. PM DEMODOFF BW > 2 * (deviation + fmod) for FM, DEMODOFF BW > 2 * fmod * (1 + deviation) for PM, RANGE / DEVIATION PER DIV 0.5 * deviation MEAS TIME 3/fmod for distortion (up to 3rd harmonic) <ul style="list-style-type: none"> RESULT DISPLAY / FM resp. PM / AF SPECTRUM DEMODOFF BW > 2 * (deviation + 3.5 * fmod) for FM, DEMODOFF BW > 7 * fmod * (1 + deviation) for PM, MEAS TIME 16/fmod

1.4.7.2 FM Setting Uncertainty

Test Method	➤ FFT Demodulation (see chapter " Test Methods ")
Measurement	<ul style="list-style-type: none"> ➤ Settings on DUT: <ul style="list-style-type: none"> RF On Level 0 dBm: Frequency Modulation menu: <ul style="list-style-type: none"> State on FM Source Internal FM Mode Normal LF Gen Frequency: 1 kHz FM deviation: 100 kHz. ➤ Repeat measurement at 1000 MHz with changing settings to <ul style="list-style-type: none"> FM Source External FM Ext Coupling AC feed in a 1 kHz, 1 Vp external modulation signal at the MOD EXT connector
Recommended test frequencies	10 MHz, 1000 MHz, 10 GHz, 20 GHz, 40 GHz

1.4.7.3 FM Distortion

Test Method	FFT Demodulation (see chapter "Test Methods")
Measurement	<ul style="list-style-type: none"> ➤ Settings on DUT: RF On Level 0 dBm: Frequency Modulation menu: State on FM Source Internal FM Mode Normal LFGGen Frequency 2 kHz. ➤ Settings on R&S FSQ: DEMOD BW 5 * FM deviation, RANGE / DEVIATION PER DIV 250 kHz, RESULT DISPLAY / FM, AF SPECTRUM, SWEEP / MEAS TIME 2.5 ms, FREQ / AF STOP 50 kHz. ➤ Read the THD from the display. To convert to percent calculate $THD_{pct} = 100 * 10^{(THD_{dB}/20)}$.
Recommended settings	<ul style="list-style-type: none"> ➤ CF sweep Recommended test frequencies with FM deviation 250 kHz: 10 MHz, with FM deviation 500 kHz: 375.1 MHz, 500 MHz, 625 MHz, 750 MHz, with FM deviation 1 MHz: 1100 MHz, with FM deviation 2 MHz: 2200 MHz, with FM deviation 4 MHz: 3200 MHz, 6.375 GHz with FM deviation 8 MHz: 6.376 GHz, 12.75 GHz with FM deviation 16 MHz: 13 GHz, 20 GHz, 20.1 GHz, 25.5 GHz with FM deviation 16 MHz: 26 GHz, 39 GHz ➤ Repeat measurement with changing settings to FM Mode Low Noise FM deviation 500 kHz for test frequencies: 375.1 MHz, 750 MHz ➤ Repeat measurement with changing settings to FM Mode High Deviation FM deviation 500 kHz for test frequencies: 375.1 MHz, 750 MHz

1.4.7.4 FM Frequency Response

Test Method	FFT Demodulation (see chapter "Test Methods")
Measurement	<ul style="list-style-type: none"> ➤ Settings on DUT: <ul style="list-style-type: none"> RF On Level 0 dBm Frequency Modulation menu: <ul style="list-style-type: none"> FM Source External FM Ext Coupling DC FM Mode Normal FM deviation: 1 MHz ➤ Setting on the signal generator: <p>The internal LF generator of the signal generator delivers the modulation signal to the external modulation input of the DUT. The level of the modulation signal is controlled by use of an AC voltmeter (Table 1-1, item 10).</p> <ul style="list-style-type: none"> - LFGGen Voltage 1 V peak - State ON ➤ Settings on R&S FSQ: <ul style="list-style-type: none"> FFT Demodulation ➤ Vary the signal generator frequency and measure the modulation depth. ⇒ The modulation frequency response is the factor between the greatest and the smallest modulation depth.

Recommended settings	<ul style="list-style-type: none"> ➤ LF in logarithmic steps, 3 steps per decade (1, 2, 5) from 10 Hz to 500 kHz ➤ Perform the measurement for test frequency 23 MHz. ➤ Repeat the measurement with changing the settings to FM Ext Coupling AC for test frequency 23 MHz. ➤ Repeat the measurement with changing the settings to FM Ext Coupling AC. <table border="1" style="margin-left: 40px;"> <thead> <tr> <th>Test frequency in MHz</th> <th>Deviation in MHz</th> </tr> </thead> <tbody> <tr> <td>375.1</td> <td>1</td> </tr> <tr> <td>3001</td> <td>8</td> </tr> <tr> <td>6375</td> <td>8</td> </tr> <tr> <td>10000</td> <td>16</td> </tr> <tr> <td>20000</td> <td>16</td> </tr> <tr> <td>40000</td> <td>8</td> </tr> </tbody> </table> <p style="margin-left: 40px;">LF sweep from 1 kHz to 500 kHz</p> <ul style="list-style-type: none"> ➤ Repeat the measurement with changing the settings to FM Ext Coupling AC FM Mode Low Noise FM deviation 500 kHz at test frequency 500 MHz. LF sweep from 1 kHz to 100 kHz ➤ Repeat the measurement with changing the settings to FM Ext Coupling AC FM Mode High Deviation FM deviation 2 MHz at test frequency 500 MHz. LF sweep from 1 kHz to 100 kHz ➤ Repeat the measurement with changing the settings to FM Source Internal FM Mode Normal FM deviation 1 MHz at test frequency 500 MHz. LF sweep from 1 kHz to 500 kHz 	Test frequency in MHz	Deviation in MHz	375.1	1	3001	8	6375	8	10000	16	20000	16	40000	8
Test frequency in MHz	Deviation in MHz														
375.1	1														
3001	8														
6375	8														
10000	16														
20000	16														
40000	8														

1.4.7.5 Synchronous AM with FM

Test assembly	See section " Standard Test Assembly for Analog Modulations ", page 1.2.
Measurement	<ul style="list-style-type: none"> ➤ Settings on DUT: <ul style="list-style-type: none"> RF On Level 0 dBm Frequency Modulation menu: <ul style="list-style-type: none"> State on FM Source Internal FM Mode Normal FM deviation 40 kHz LFGGen Frequency 1 kHz. ➤ Settings on spectrum analyzer <ul style="list-style-type: none"> AMPTD / REF LEVEL 6 dBm FREQ / CENTER test frequency FMDEMOD, <ul style="list-style-type: none"> FMDEMOD ON, RESULT DISPLAY / AM / AF Spectrum AF Start = 0 Hz AF Stop = 5 kHz RES BW = 30 Hz DEMOD BW = 100 kHz IF BW MANUAL 10 MHz, RANGE / REFERENCE VALUE 0.2 % MEAS TIME 3 ms ➤ Read the AM depth at 1 kHz modulation frequency from the demodulated AF spectrum.
Recommended settings	<ul style="list-style-type: none"> ➤ CF sweep Recommended test frequencies: 23.4 MHz, 375 MHz, 500 MHz, 750 MHz, 1100 MHz, 2200 MHz, 3200 MHz, 6.375 GHz, 6.376 GHz, 7.2 GHz, 10 GHz, 12.75 GHz, 13 GHz, 16 GHz, 20 GHz, 26 GHz, 30 GHz, 40 GHz

1.4.7.6 Carrier Frequency Offset with FM

Test assembly	See section " Standard Test Assembly for Analog Modulations ", page 1.2.
Measurement	<ul style="list-style-type: none"> ➤ Settings on DUT: <ul style="list-style-type: none"> RF On Level 0 dBm Frequency 1 GHz Frequency Modulation menu: <ul style="list-style-type: none"> State on FM Source Internal FM Mode Normal FM deviation 1 MHz LFGen Frequency 10 kHz ➤ Settings on spectrum analyzer <ul style="list-style-type: none"> AMPT / REF LEVEL 0 dBm FREQ / CENTER 1 GHz SPAN 10 kHz MKR / SIGNAL COUNT / NEXT / CNT RESOL 10 Hz <ul style="list-style-type: none"> ➤ Terminate the DUT External Modulation input with 50 Ω and execute the internal FM offset adjustment. ➤ Execute a single sweep. Using MKR→ / PEAK, read counted marker frequency. ⇒ The offset is the difference between marker frequency and set carrier frequency. ➤ Repeat measurement with FM source external, coupling ac and dc (2 measurements).

1.4.8 Phase Modulation

1.4.8.1 PhiM Setting Uncertainty

Test Method	FFT Demodulation (see chapter " Test Methods ").
Measurement	<ul style="list-style-type: none"> ➤ Settings on DUT: RF On Level 0 dBm Phase Modulation menu: State on PhiM Source Internal PhiM Mode Normal PhiM Deviation 1 rad LFGen Freq = 1 kHz ➤ Settings on spectrum analyzer: see chapter "Test" ➤ Repeat measurement at 500 MHz with changing settings to PhiM Source External PhiM Ext Coupling AC feed in a 1 kHz external modulation signal at MOD EXT connector
Recommended test frequencies	10 MHz, 500 MHz, 10 GHz, 20 GHz, 39.999 GHz

1.4.8.2 PhiM Distortion

Test Method	FFT Demodulation (see chapter " Test Methods ")
Measurement	<ul style="list-style-type: none"> ➤ Settings on DUT: RF On Level 0 dBm Phase Modulation menu: State on PhiM Source Internal PhiM Mode Normal LFGen Frequency 10 kHz ➤ Settings on R&S FSQ: see chapter "Test Methods" SWEEP / MEAS TIME 2.5 ms, FREQ / AF STOP 50 kHz, AMPTD / REF LEVEL 0 dBm, FREQ / CENTER test frequency. ➤ Read THD from the Display. To convert to percent calculate $THD_{pct} = 100 * 10^{(THD_{dB}/20)}$.

Recommended settings	<ul style="list-style-type: none"> ➤ CF sweep Recommended test frequencies with PhiM deviation 1 rad: 10 MHz, 375.1 MHz, 500 MHz, 625 MHz, 750 MHz, with PhiM deviation 2 rad: 1100 MHz, with PhiM deviation 4 rad: 2200 MHz, with PhiM deviation 8 rad: 3200 MHz, 6.375 GHz with PhiM deviation 16 rad: 6.376 GHz, 12.75 GHz with PhiM deviation 32 rad: 13 GHz, 20 GHz, 20.1 GHz, 25.5 GHz with PhiM deviation 64 rad: 26 GHz, 40 GHz ➤ Repeat measurement with changing settings to PhiM Mode Low Noise PhiM deviation 2.5 rad for test frequencies: 375.1 MHz, 750 MHz ➤ Repeat measurement with changing settings to PhiM Mode High Deviation PhiM deviation 10 rad for test frequencies: 375.1 MHz, 750 MHz
----------------------	--

1.4.8.3 PhiM Frequency Response

Test method	FFT Demodulation (see chapter " Test Methods ").
Measurement	<ul style="list-style-type: none"> ➤ Settings on DUT: RF On Level 0 dBm Phase Modulation menu: PhiM Source External PhiM Ext Coupling DC PhiM Mode Normal PhiM deviation: 2 rad ➤ Setting on the signal generator: The internal LF generator of the signal generator delivers the modulation signal to the external modulation input of the DUT. The level of the modulation signal is controlled by use of an AC voltmeter (Table 1-1, item 10) - LFGGen Voltage 1 V peak - State ON ➤ Settings on R&S FSQ: FFT Demodulation ➤ Vary the signal generator frequency and measure the modulation depth. ⇒ The modulation frequency response is the factor between the greatest and the smallest modulation depth.

Recommended settings	<ul style="list-style-type: none"> ➤ LF in logarithmic steps, 3 steps per decade (1, 2, 5) from 10 Hz to 500 kHz ➤ Perform the measurement for test frequency 23 MHz ➤ Repeat the measurement with changing the settings to PhiM Ext Coupling AC for test frequency 23 MHz. ➤ Repeat the measurement with changing the settings to PhiM Ext Coupling AC <table border="1" style="margin-left: 40px;"> <thead> <tr> <th>Test frequency in MHz</th> <th>Deviation in rad</th> </tr> </thead> <tbody> <tr> <td>375.1</td> <td>2</td> </tr> <tr> <td>3001</td> <td>16</td> </tr> <tr> <td>6375</td> <td>16</td> </tr> <tr> <td>10000</td> <td>32</td> </tr> <tr> <td>20000</td> <td>32</td> </tr> <tr> <td>40000</td> <td>16</td> </tr> </tbody> </table> <p style="margin-left: 40px;">LF sweep from 1 kHz to 500 kHz</p> <ul style="list-style-type: none"> ➤ Repeat the measurement with changing the settings to PhiM Ext Coupling AC PhiM Mode Low Noise PhiM deviation 5 rad at test frequency 500 MHz. LF sweep from 1 kHz to 100 kHz ➤ Repeat the measurement with changing the settings to PhiM Ext Coupling AC PhiM Mode High Deviation PhiM deviation 20 rad at test frequency 500 MHz. LF sweep from 1 kHz to 100 kHz ➤ Repeat the measurement with changing the settings to PhiM Source Internal PhiM Mode Normal PhiM deviation 2 rad at test frequency 500 MHz. LF sweep from 1 kHz to 500 kHz 	Test frequency in MHz	Deviation in rad	375.1	2	3001	16	6375	16	10000	32	20000	32	40000	16
Test frequency in MHz	Deviation in rad														
375.1	2														
3001	16														
6375	16														
10000	32														
20000	32														
40000	16														

1.4.9 Pulse Modulation

1.4.9.1 ON/OFF Ratio

Test equipment	- Spectrum analyzer (Table 1-1 , item 1)
Test setup	➤ To determine the ON/OFF ratio, connect the spectrum analyzer to the RF output socket of the DUT and let the PULSE EXT input open.
Measurement	<p>➤ Setting on DUT: RF On Frequency recommended test frequencies Pulse Modulation menu: Source External State On Polarity Inverse</p> <p>➤ Setting on Analyzer FREQ/CENTER test frequency SPAN 0 Hz AMPT/REF LEVEL 0 dBm BW ⇒ RES BW MANUAL 3 kHz SWEEP ⇒ SWEEP TIME MANUAL 100 ms MEAS ⇒ TIME DOM POWER on</p> <p>➤ Determine the output level of the DUT at the recommended test frequencies with Pulse Modulation ⇒ Polarity Inverse and Pulse Modulation ⇒ Polarity Normal.</p> <p>⇒ The level difference between the output level with Polarity Inverse and Polarity Normal is the ON/OFF ratio.</p>
Recommended test frequencies	5 MHz, 150 MHz, 400 MHz, 1.1 GHz, 2.2 GHz, 3.2 GHz, 4 GHz, 5 GHz, 6.375 GHz 6375.1 MHz to fmax in 50 MHz steps
Recommended test level for instruments equipped with R&S SMB-B112L/B120L/B140L	- Level: 0 dBm
Recommended test level for instruments equipped with R&S SMB-B112/B120/B140	- Level: 0 dBm - determine Att-fixed range upper Level P_{upper} : - ⇒ RF ⇒ Level ⇒ Att fixed range ⇒ upper - set level to $P_{upper} + 0.1$ dB

1.4.9.2 Rise/ Fall Time

Test assembly	Test Assembly for Pulse Modulation (see page 1.3)
Test method	The RF signal is detected by a microwave detector diode. Thus, the video output of the detector reproduces the RF amplitude vs. time.
Measurement	<ul style="list-style-type: none"> ➤ Setting on pulse generator: For adjustment statically high level, for measurement square wave pulse sequence with a frequency of 1 MHz, TTL level ➤ Setting on DUT: RF On Level 0 dBm Frequency recommended test frequencies Pulse Modulation menu: State On ➤ Setting on oscilloscope: Adjust V/div according to the video output of the used detector Time base 20 ns/div Trigger: - for adjustment free running, - for measurement 50 % of signal amplitude, rising and falling edge. ➤ Measurement: Evaluate the down converted pulse-modulated signal on the oscilloscope. <p style="margin-left: 40px;">⇒ Rise time = time between 10 % and 90 % of signal amplitude Fall time = time between 90 % and 10 % of signal amplitude</p>
Recommended test frequencies	700 MHz, 1.1 GHz, 2.2 GHz, 3.2 GHz, 4 GHz, 5 GHz, 6.375 GHz, 6.376 GHz, 7.2 GHz, 8 GHz, 9 GHz, 10 GHz, 11 GHz, 12 GHz, 12.75 GHz; 13 GHz; 16 GHz; 20 GHz; 20.01 GHz; 25.5 GHz, 25.6 GHz, 30 GHz, 40 GHz

1.4.9.3 Video Crosstalk

Test assembly	As above for ON/OFF Ratio
Measurement	<ul style="list-style-type: none"> ➤ Setting on pulse generator: Square wave pulse sequence with a frequency of 100 kHz, TTL level ➤ Setting on DUT: RF On Frequency test frequencies Level maximum specified level Pulse Modulation State On ➤ Settings on the Analyzer REF LEVEL 0 dBm FREQ CENTER 100 kHz SPAN 10 kHz ➤ Measure the signal level at 100 kHz with the analyzer. <ul style="list-style-type: none"> ⇒ The Video Crosstalk is the amplitude of the spectral line found at 100 kHz related to the RF carrier level
Recommended test frequencies	23.4375 MHz , 23.4376 MHz, 1 GHz, 6.5 GHz, 7.15 GHz, 7.151 GHz, 12.75 GHz; 13 GHz; 16 GHz; 20 GHz; 20.01 GHz; 25.5 GHz, 25.6 GHz, 30 GHz, 39.95 GHz
Recommended test level	Pmax

1.4.10 Pulse Generator

1.4.10.1 PULSE VIDEO

Test equipment	- Storage oscilloscope (Table 1-1 , item 6) with 50 Ω Feed-through termination on input.
Test setup	➤ Connect the PULSE VIDEO socket on the rear of the DUT to the storage oscilloscope.
Measurement	<p>Setting on DUT:</p> <p>Pulse Modulation menu:</p> <p> State On</p> <p> Source: Pulse Generator</p> <p>Pulse Generator menu:</p> <p> State On</p> <p> Pulse Period 10 μs</p> <p> Pulse Width 5 μs</p> <p>➤ Setting on oscilloscope:</p> <p> 1 V/div</p> <p> Time base 2.5 μs/div</p> <p> Trigger: 50 % of amplitude, rising edge.</p> <p>➤ Check the signal for a symmetric square wave with 10 μs pulse period and 3 V amplitude.</p> <p> Rise and fall time < 10 ns</p>

1.4.11 Hardware Signals

1.4.11.1 SIGNAL VALID

Test equipment	- Spectrum analyzer (Table 1-1 , item 1)
Test setup	➤ Apply connection from the SIGNAL VALID socket on the rear of the DUT to external trigger input of the spectrum analyzer.
Test method	The function of the Signal is tested by triggering the spectrum analyzer.
Measurement	<p>➤ Setting on DUT:</p> <p> - Frequency: 100 MHz</p> <p>➤ Settings on spectrum analyzer:</p> <p> - TRIGGER EXTERN</p> <p> - External triggering by negative edge at 1.4 V.</p> <p>➤ Change DUT Frequency to 1 GHz</p> <p>➤ Check trigger on analyzer.</p>

Contents - Chapter 2 "Procedures after Module Replacement"

2	Procedures after Module Replacement	2.1
2.1	Procedures after Replacing the Lithium Battery	2.3
2.2	Procedures after Replacing the Basis Board	2.3
2.3	Adjustments	2.3
2.3.1	Internal Adjustments	2.3
2.3.2	External Adjustments Requiring Measurement Equipment	2.3
2.3.3	External Level Correction	2.4
2.3.3.1	Level 1: Full Level Correction	2.4
2.3.3.2	Level 2: Partial Level Correction for High Output Levels	2.5
2.3.4	Adjustment of internal Reference Frequency	2.6
2.4	Internal Self Test	2.7

2 Procedures after Module Replacement

This chapter describes all necessary measures to restore the performance of the R&S SMB after module replacement

There are no manual adjustments to be performed. Internal and external adjustment routines are implemented for this purpose.

All spare part boards are tested at Rohde & Schwarz with calibrated working standards according to the performance test. All measurement values are within the specified values including the measurement uncertainty as a minimum guard band.

The power levels of all spare part modules are pre-corrected at factory side, but level errors due to mismatch between RF Board, Step Attenuator and Reverse Power Protection module must be corrected at the instruments RF output.

For details see chapter [External Level Correction](#).

OCXOs are tested at Rohde & Schwarz for the frequency adjustment range and the control voltage for an exact 10 MHz output frequency. This control voltage is coded in a digital value and stored on the OCXO module.

Allow the DUT to warm up for at least 30 minutes, before performing in internal or external adjustment. If a calibration of the instrument is required the performance test should be performed completely.

After replacing an assembly, check the following table to see which service procedure you perform.

Table 2-1: Overview of service procedures after modules replacement

Changed module	Required adjustment/correction	Recommended Test Procedure (refer to chapter 1 Performance Test "Checking the rated characteristics")
Basis Board	Setup/Internal Adjustments/Adjust All set correct time and date, see below.	None
RF Board 13 GHz	Setup/Internal Adjustments/Adjust All External Level Correction	Level uncertainty Reference Frequency "Output of Internal Reference" (for instruments without option R&S SMB-B1 or R&S SMB-B1H)
RF Board 20 GHz	Setup/Internal Adjustments/Adjust All External Level Correction	Level uncertainty
HP20	Setup/Internal Adjustments/Adjust All External Level Correction	Level uncertainty
Filter20	Setup/Internal Adjustments/Adjust All External Level Correction	Level uncertainty
FD40	Setup/Internal Adjustments/Adjust All External Level Correction	Level uncertainty
FD40P	Setup/Internal Adjustments/Adjust All External Level Correction	Level uncertainty
Attenuator 13 GHz	Setup/Internal Adjustments/Adjust All External Level Correction	Level uncertainty
Reverse Power Protection 13 GHz	Setup/Internal Adjustments/Adjust All External Level Correction	Level uncertainty
ATT40	Setup/Internal Adjustments/Adjust All External Level Correction	Level uncertainty
OCXO	Setup/Internal Adjustments/Adjust All	Reference Frequency "Output of Internal Reference"
Power Supply	Setup/Internal Adjustments/Adjust All	None

2.1 Procedures after Replacing the Lithium Battery

1. Connect an USB keyboard to the R&S SMB.
2. Switch on the R&S SMB. The operating system (LINUX) and the R&S SMB firmware will start.
3. Set correct date and time at R&S SMB setup menu.

2.2 Procedures after Replacing the Basis Board

Required equipment

USB Memory Stick (at least 128 MB)

Required software

Actual SMB_Firmware see R&S homepage www.rohde-schwarz.com

Copy the firmware to the root folder of the memory stick.

Install the new Firmware

See chapter 4 "Software Update".

2.3 Adjustments

Preliminary Remark

Setting a defined **initial** state by pressing the **PRESET** key prior to adjustments is recommended. In addition, a valid reference frequency is required, either by setting the instrument to internal reference or by applying an appropriate external reference signal. To ensure that the internal adjustments are valid at operating temperature, at least **20 minutes warm-up time** at this temperature must be observed.

2.3.1 Internal Adjustments

All internal adjustments are available in the **Setup/Internal Adjustments** menu (see operating manual).

Performing **Setup/Internal Adjustments/Adjust All** activates all internal adjustments in a reasonable order.

2.3.2 External Adjustments Requiring Measurement Equipment

The external adjustments have to be performed, if the recommended calibration interval is exhausted or after a module replacement (according to Table 2-1).

The external adjustments require calibrated equipment and special software. If required, contact your local Rohde & Schwarz representative. Data sheet specifications of the unit are concerned.

2.3.3 External Level Correction

External level correction measures output power over frequency and level and stores the correction values inside the instrument to maintain level accuracy. The R&S SMB provides a build in measuring procedure for external level correction for high output levels. An external level correction for low output levels (approx < 0 dBm) requires calibrated equipment and special software. If required, contact your local Rohde & Schwarz representative.

NOTICE**Risk of damage to the power sensor**

Power sensor NRP-Zxx can be damaged when being exposed to R&S SMBs maximum output power. So it is recommended to PRESET the instrument before connecting the power sensor. The build-in level correction procedure does not overload the sensor.

There are 3 possible options for level correction.

- **Level 1: Full level correction**

This is the most preferred option and should normally be performed after a module replacement. All full level correction routines require calibrated equipment and special software. If required, contact your local Rohde & Schwarz representative. A full level calibration can only be performed after a full level correction.

- **Level 2: Partial level correction**

This option should only be performed, if it is not possible to perform a full level correction. In this case, it is possible to execute an external level correction only for high output levels (approx. > 0 dBm) by use of a thermal R&S NRP-Z power sensor together with the R&S SMB (see chapter [External Level Correction](#) below). After this adjustment the level accuracy is within its specification for high output levels. For low output levels (approx < 0 dBm), the output level is uncalibrated and no level data is guaranteed. The maximum level error in this level range can exceed 1 dB.

- **Level 3: No level correction**

This option should only be performed, if no applicable R&S NRP-Z power sensor is available. It is not possible to calibrate the output level of the instrument and therefore level accuracy will not be within specified range. The level error of such an uncorrected instrument will exceed 1 dB.

2.3.3.1 Level 1: Full Level Correction

An external level correction over the complete output level range can only be performed at a Rohde & Schwarz service center.

2.3.3.2 Level 2: Partial Level Correction for High Output Levels

This feature will be available with a new firmware release until end of 2011.

- | | |
|----------------|--|
| Test equipment | ➤ R&S NRP-Z55 power sensor with NRP-Z3 or NRP-Z4 USB adaptor |
| Test setup | <ul style="list-style-type: none"> ➤ Power on instrument ➤ Setting on instrument: <ul style="list-style-type: none"> PRESET Setup Menu Reference Oscillator Source INTERNAL Protection Protection Level 2 = 147946 ENTER ➤ Connect the power sensor to the RF plug and to the USB connector of the instrument. ➤ Allow the R&S SMB and the power sensor to warm up for at least 20 minutes |
| Adjustment | <ul style="list-style-type: none"> ➤ Setting on instrument: <ul style="list-style-type: none"> Setup Menu External Adjustments External Level Adjustment Adjust Ext Level... |

Note that the R&S factory level correction data is not replaced by this procedure, instead an additional data set is created.

The active correction data set is selected by the setting

- Setup Menu
 - External Adjustments
 - External Level Adjustment
 - Active Adjustment Data CUSTOM

2.3.4 Adjustment of internal Reference Frequency

The frequency accuracy of the synthesizer is determined (set to internal reference) by a 200 MHz VTCXO or when the Option R&S SMB-B1 or R&S SMB-B1H is fitted with a highly stable OCXO that is set to a calibrated frequency standard at the R&S factory. This oscillator is subject to ageing and hence its output frequency can be adjusted.

Important: Allow the DUT to warm up for at least 20 minutes before adjustment is executed

- | | |
|----------------|--|
| Test equipment | - External frequency counter (1 Hz to RF_{max} , resolution 0.1 Hz) |
| Test setup | ➤ Connect a calibrated external frequency counter to the reference output at the rear panel. |
| Adjustment | ➤ Setting on DUT: |

PRESET

Setup Menu

Protection

Protection Level 2 = 147946 ENTER

- Setting on spectrum analyzer (external frequency counter):

MKR SIGNAL COUNT

MKR / NEXT CNT RESOL 0.1 Hz

- Adjust the TCXO/ OCXO Calibration Value (Setup - Reference Oscillator - Calibration Value) for an external frequency counter reading of 10 MHz, with minimal error.
- Setting on instrument:

Setup Menu

External Adjustments

OCXO Adjustment

Write Value to Eeprom...

Note that the R&S factory adjustment data is not replaced by this procedure, instead an additional data set is created.

The active adjustment data set is selected by the setting

Setup Menu

External Adjustments

OCXO Adjustment

Active Adjustment Data CUSTOM

2.4 Internal Self Test

After each module replacement, it is recommended to perform the internal self test (refer to chapter 3, "Troubleshooting with Internal Self Test"). The self test checks the instrument by measuring internal diagnostic points and verifies whether generator is operating properly.

If a self test failure occurs, check again whether all cables are properly connected. If the self test fails continuously, contact your local service center.

Contents – Chapter 3 "Repair"

3 Repair	3.1
3.1 Instrument Design and Function Description	3.1
3.1.1 Block diagram	3.1
3.1.2 Power Supply Module	3.4
3.1.3 Basis Board Module	3.5
3.1.3.1 Fuses	3.5
3.1.3.2 Switching regulators	3.5
3.1.3.3 Controller	3.5
3.1.3.4 FPGA (SMB_COM)	3.5
3.1.3.5 Keyboard Controller	3.5
3.1.3.6 Diagnostic ADC	3.5
3.1.3.7 EEPROM	3.5
3.1.3.8 Temperature sensor	3.5
3.1.3.9 Fan Controller	3.6
3.1.4 RF Board 13 Module	3.7
3.1.4.1 Implemented functions	3.7
3.1.4.2 Internal and external 10 MHz reference	3.7
3.1.4.3 TCXO 200 MHz crystal oscillator	3.7
3.1.4.4 RF Synthesizer/ DDS module	3.8
3.1.4.5 Harmonic filters	3.8
3.1.4.6 Band-pass filters	3.8
3.1.4.7 LO output	3.8
3.1.4.8 LF generator	3.8
3.1.4.9 Pulse Generator and Pulse Modulator	3.8
3.1.4.10 Modulation matrix and AM/FM/φM modulator	3.9
3.1.4.11 Power Amplifiers	3.9
3.1.4.12 Automatic Level control	3.9
3.1.4.13 Supply voltage control and filtering	3.9
3.1.5 Reference Oscillator Module	3.10
3.1.6 Active Step Attenuator Module	3.10
3.1.6.1 Implemented functions	3.10
3.1.6.2 Switching matrix	3.10
3.1.6.3 Power Amplifiers	3.10
3.1.6.4 Voltage Regulators and filtering	3.11
3.1.7 Reverse Power Protection Module	3.11
3.1.8 RFBOARD20 Module	3.11
3.1.8.1 Implemented functions	3.11
3.1.8.2 Frequency doubler	3.12
3.1.8.3 Band pass filters	3.12
3.1.8.4 Variable Attenuator	3.12
3.1.8.5 Pulse Modulator	3.12
3.1.8.6 Signal Amplifiers	3.12
3.1.8.7 Frequency band switches	3.12
3.1.8.8 Level control hardware	3.12
3.1.8.9 Digital control and diagnostics	3.13
3.1.9 HP20 Module	3.13
3.1.9.1 Implemented functions	3.13
3.1.9.2 Broadband high power amplifiers	3.13
3.1.9.3 Level control hardware	3.13
3.1.9.4 Digital control and diagnostics	3.13

3.1.10	FILTER20 Module	3.14
3.1.10.1	Implemented functions	3.14
3.1.10.2	Switchable low pass filters	3.14
3.1.10.3	all other functions	3.14
3.1.11	FD40 / FD40P Module.....	3.15
3.1.11.1	Implemented functions	3.15
3.1.11.2	Frequency doubler	3.15
3.1.11.3	Band pass filters.....	3.15
3.1.11.4	Signal Amplifiers.....	3.16
3.1.11.5	Frequency band switch	3.16
3.1.11.6	Level control hardware.....	3.16
3.1.11.7	Digital control and diagnostics.....	3.16
3.1.12	ATT40 Module.....	3.16
3.1.12.1	Implemented functions	3.16
3.1.12.2	Step attenuator.....	3.16
3.1.12.3	Digital control and diagnostics.....	3.17
3.2	Troubleshooting - Instrument.....	3.18
3.2.1	Measuring Equipment and Accessories.....	3.19
3.2.2	Switch-On Problems.....	3.19
3.2.2.1	Switch-on.....	3.19
3.2.2.2	Switch-off.....	3.21
3.2.3	Problems with Booting.....	3.22
3.2.4	Keyboard and Rotary Knob Test.....	3.22
3.2.5	USB Cable Test.....	3.23
3.2.6	Troubleshooting with Internal Selftest	3.23
3.2.7	Troubleshooting with Internal Adjustments	3.25
3.2.8	Instrument Faults.....	3.26
3.2.9	Troubleshooting – Basis Board Module	3.32
3.2.9.1	Supply Voltages	3.32
3.2.9.2	Fuses.....	3.33
3.2.10	Troubleshooting – RF Board 13 Module	3.34
3.2.10.1	Internal Adjustment "Adjust All".....	3.34
3.2.10.2	Supply Voltages	3.34
3.2.10.3	Control Signals	3.35
3.2.10.4	Input and Output Signals.....	3.37
3.2.10.5	Error Messages Concerning the RF Board Module	3.37
3.2.10.6	Warnings Concerning the RF Board Module	3.38
3.2.10.7	Frequency Error	3.39
3.2.11	Troubleshooting – Reference Oscillator Module	3.40
3.2.11.1	Input and Output Signals.....	3.40
3.2.11.2	Error Messages Concerning the Reference Oscillator Module.....	3.41
3.2.11.3	Frequency Error, Reference Oscillator Adjustment.....	3.41
3.2.12	Troubleshooting – Active Step Attenuator Module.....	3.42
3.2.12.1	Supply Voltages	3.42
3.2.13	Troubleshooting – Reverse Power Protection Module.....	3.44
3.2.13.1	Supply Voltages	3.44
3.2.13.2	Warnings Concerning the Reverse Power Protection Module.....	3.44
3.2.14	Troubleshooting – RFBOARD20 Module.....	3.45
3.2.14.1	Wiring and cables.....	3.45
3.2.14.2	Checking input and output signals	3.45
3.2.15	Troubleshooting – HP20 / FILTER20 Module	3.47
3.2.15.1	Wiring and cables.....	3.47
3.2.15.2	Checking input and output signals	3.47

3.2.16	Troubleshooting – FD40 / FD40P Module	3.48
3.2.16.1	Wiring and cables	3.48
3.2.16.2	Checking input and output signals	3.48
3.2.17	Troubleshooting – ATT40 Module	3.50
3.2.17.1	Wiring and cables	3.50
3.2.17.2	Checking input and output signals	3.50
3.3	Module Replacement	3.51
3.3.1	Overview of the Modules	3.52
3.3.2	After replacing an assembly	3.53
3.3.3	Dismounting the Case	3.53
3.3.4	Mounting the Case	3.53
3.3.5	Replacing Fuses	3.54
3.3.6	Replacing the Front Cover and the Front Unit (A300)	3.55
3.3.6.1	Removing the Front Cover	3.55
3.3.6.2	Removing the Front Unit	3.55
3.3.6.3	Mounting the Front Unit	3.58
3.3.6.4	Mounting the Front Cover	3.58
3.3.6.5	Replacing the TFT Display (A330), Encoder Board (A310), Flex. Switch Board and Pushbutton Board Set	3.58
3.3.6.6	Replacing the Encoder Board	3.59
3.3.6.7	Replacing the TFT Display, Flex. Switch Board and Pushbutton Board Set	3.60
3.3.7	Replacing the Basis Board 3 (A100)	3.62
3.3.7.1	Removing the Basis Board	3.62
3.3.7.2	Installing the Basis Board	3.64
3.3.7.3	Replacing the Battery (G1)	3.64
3.3.7.4	Replacing the SIM Card	3.66
3.3.8	Replacing the RF-Board (A200)	3.67
3.3.8.1	Removing the RF-Board	3.67
3.3.8.2	Installing the RF-Board	3.68
3.3.9	Replacing the Power Supply (A50)	3.69
3.3.9.1	Removing the Power Supply	3.69
3.3.9.2	Installing the Power Supply	3.70
3.3.10	Replacing the Fan Unit (E1, E2)	3.70
3.3.11	Replacing the Reference Oscillator Option R&S SMB-B1/B1H (A210)	3.71
3.3.11.1	Removing the Reference Oscillator	3.71
3.3.11.2	Installing the Reference Oscillator	3.71
3.3.12	Replacing the ASATT 13 GHz included in Option R&S SMB-B112 (A950)	3.72
3.3.12.1	Removing the ASATT 13 GHz	3.72
3.3.12.2	Installing the ASATT 13 GHz	3.72
3.3.13	Replacing the Reverse Power Protection included in Option R&S SMB-B30 (A980)	3.73
3.3.13.1	Removing the Reverse Power Protection	3.73
3.3.13.2	Installing the Reverse Power Protection	3.73
3.3.14	Replacing the RF Board 20 GHz (A220), 1406.7407.02 (included in options R&S SMB-B120/-B131/-B140/-B140N)	3.74
3.3.14.1	Removing the RF Board 20 GHz	3.74
3.3.14.2	Replacing the RF Board 20 GHz	3.75
3.3.15	Replacing the HP20 (A970) 1407.1290.02 (included in options R&S SMB-B31 and R&S SMB-B32)	3.75
3.3.15.1	Removing the HP20 module	3.75
3.3.15.2	Replacing the HP20 module	3.76

3.3.16	Replacing the Filter20 (A920) 1407.1690.02	
	(included in options R&S SMB-B25 and R&S SMB-B26)	3.76
3.3.16.1	Removing the Filter20 module	3.76
3.3.16.2	Replacing the Filter20 module.....	3.77
3.3.17	Replacing the Step Attenuator (A960) 1170.0094.02 / 1170.0113.02 (included in options R&S SMB-B120/-B131/-B140/-B140N).....	3.78
3.3.17.1	Removing the step attenuator	3.78
3.3.17.2	Replacing the step attenuator	3.78
3.3.18	Replacing the Doubler FD40 (A820) 1312.1006.02/.27/.31 (included in R&S SMB-B131/-B140/-B140N)	3.79
3.3.18.1	Removing the Doubler FD40.....	3.79
3.3.18.2	Replacing the Doubler FD40	3.79
3.3.19	Replacing the Doubler FD40 P (A990) 1315.0500.02/.27/.31 (included in option R&S SMB-B32 High Output Power)	3.80
3.3.19.1	Removing the Doubler FD40P	3.80
3.3.19.2	Replacing the Doubler FD40P.....	3.80

3 Repair

3.1 Instrument Design and Function Description

3.1.1 Block diagram

A schematic of the signal generator's design is presented below as block diagrams at module level for different frequency options

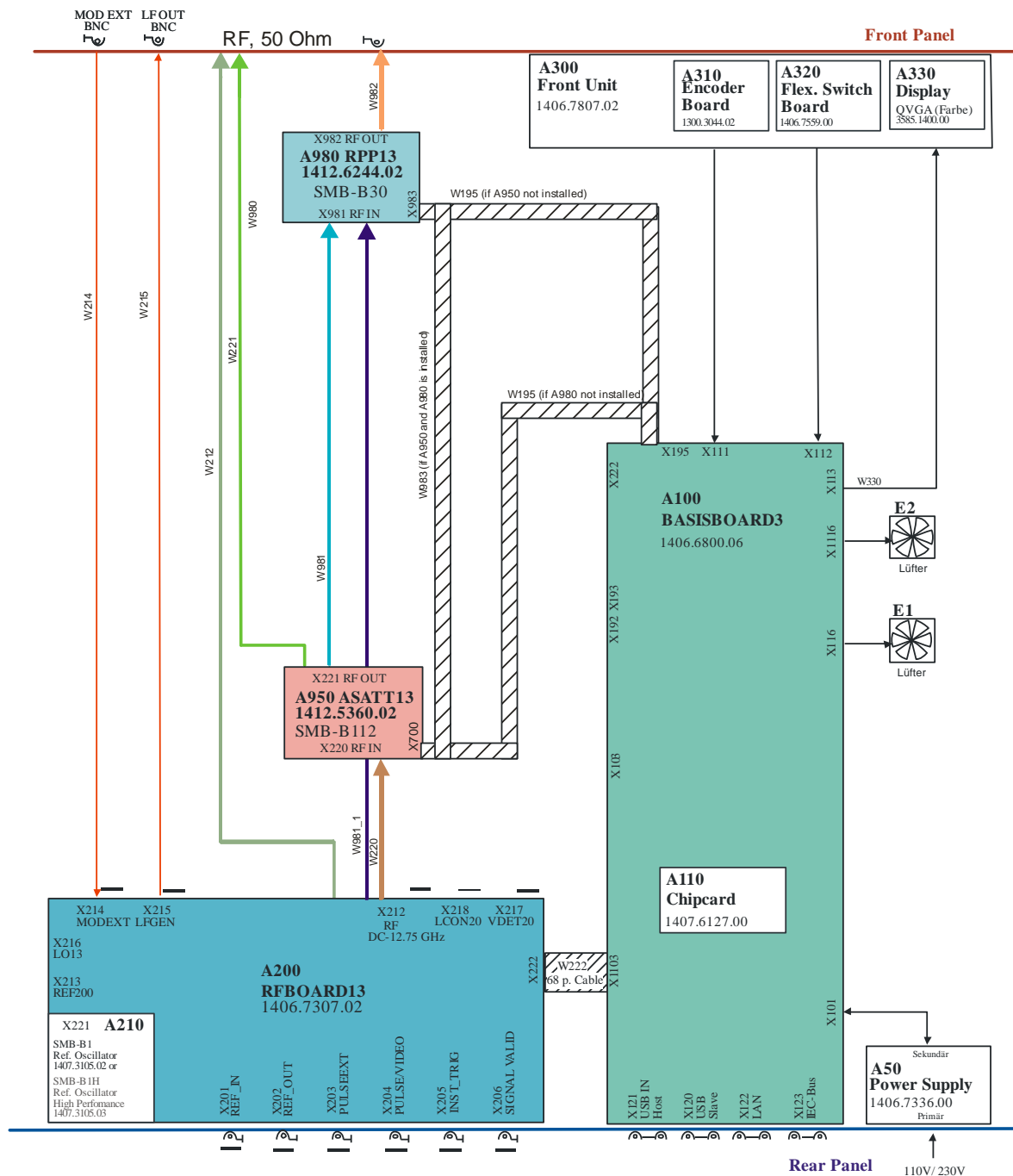

Fig. 3-1 Block diagram for instrument equipped with R&S SMB-B112 and R&S SMB-B30

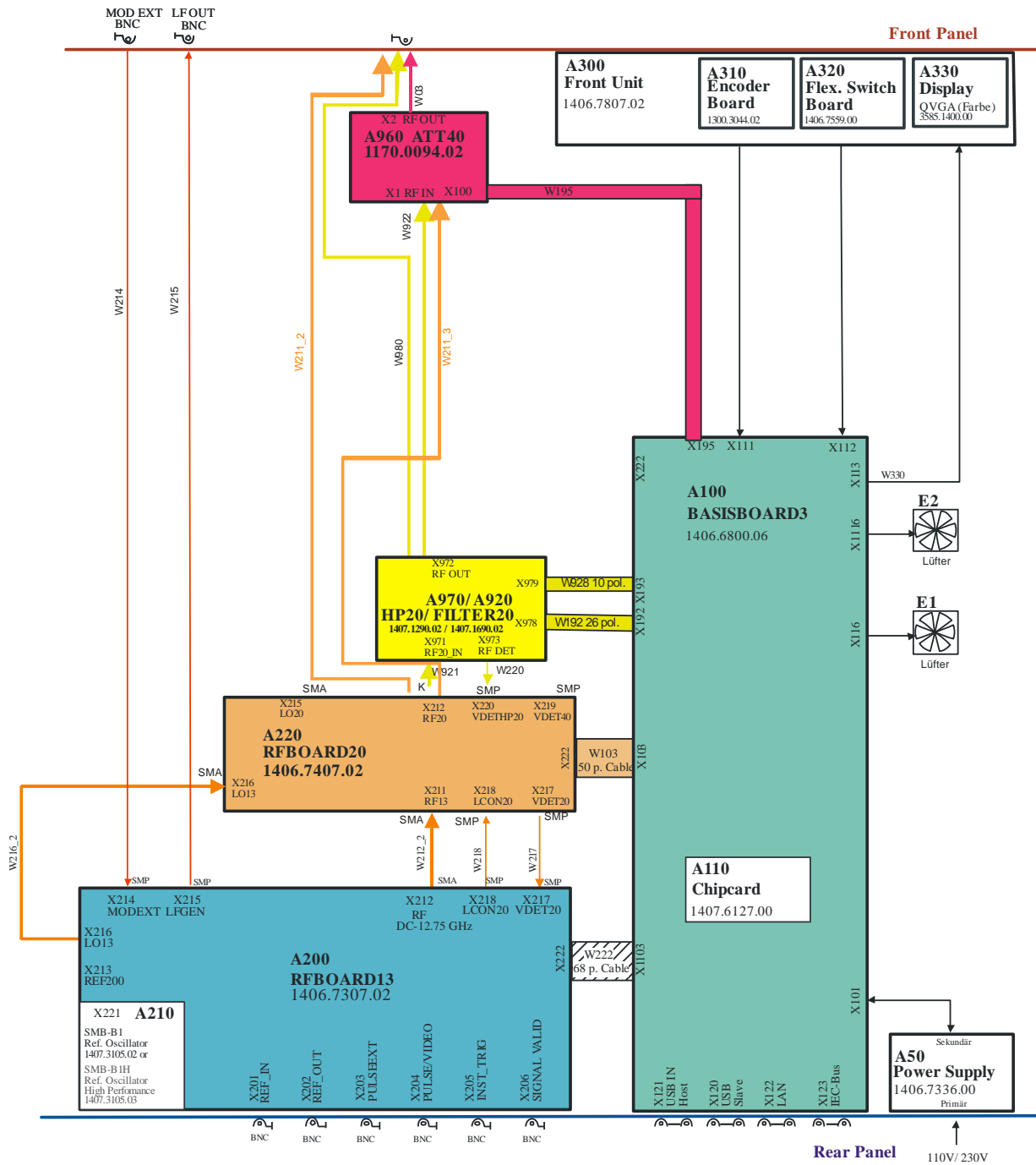

Fig. 3-2 Block diagram for instrument equipped with R&S SMB-B120 and R&S SMB-B31/B25

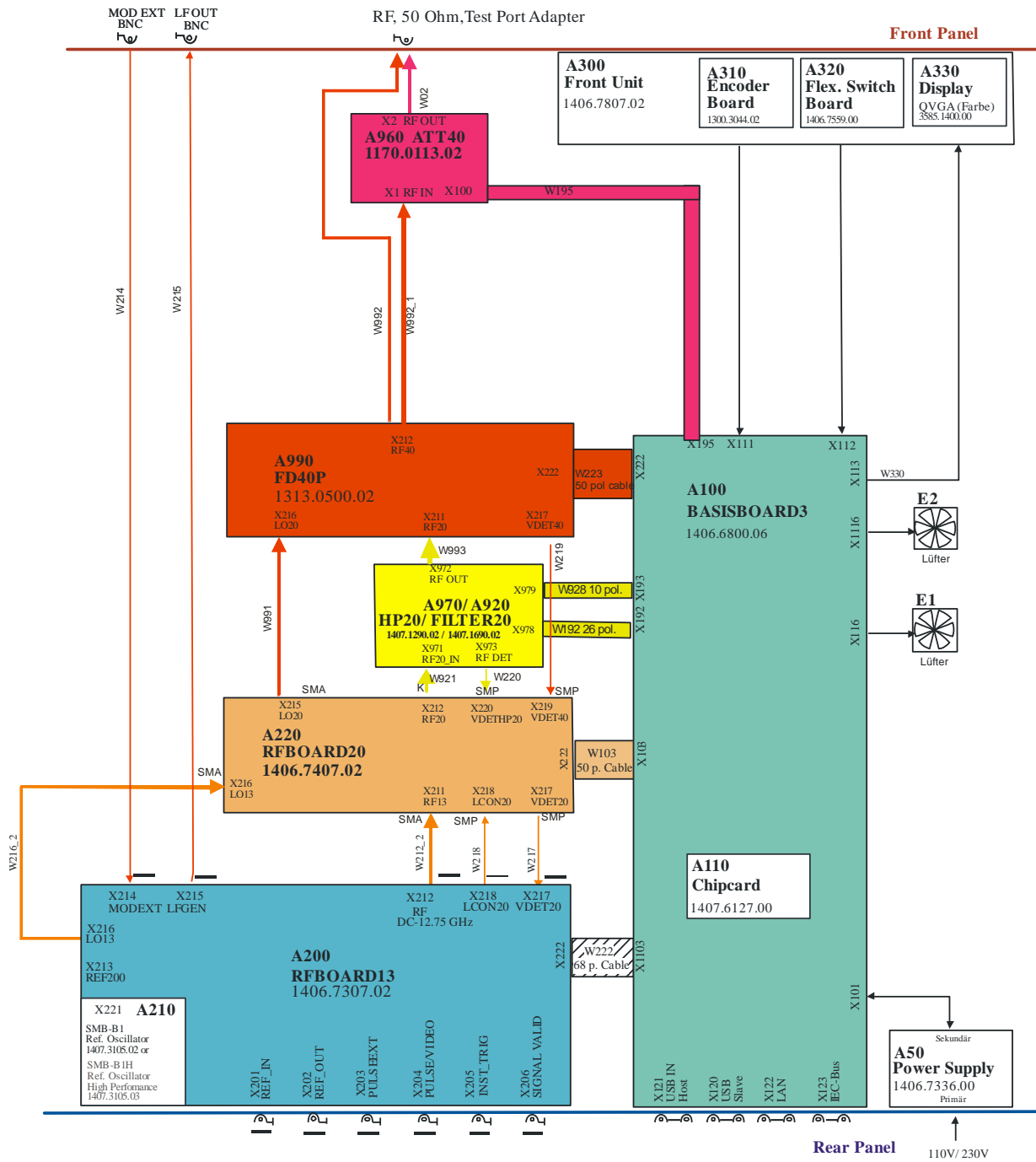

Fig. 3-3 Block diagram for instrument equipped with R&S SMB-B131/-B140 and R&S SMB-B32/B26

The R&S SMB consists of few main modules and few connections between these modules. The main units are:

- Power Supply
- Basis Board which includes all digital external Interfaces, the main CPU, the Fan control logic, the hardware drivers for the front panel and the Interface for the RF Board
- Front Unit consisting of the rotary knob with encoder, the flexible switch board and the QVGA Color Display
- RF Board 13 including the signal generator hardware up to 12.75 GHz
- R&S SMB-B1 or R&S SMB-B1H Reference Oscillator (optional) which is plugged directly into the RF Board
- ASATT13 Electronic Step Attenuator (optional)
- RPP13 Reverse Power Protection (optional)
- RFBOARD20 including the frequency doubler up to 20 GHz (optional)
- HP20 including the high power amplifier from 100 kHz to 20 GHz (optional)
- FILTER20 including the high power amplifier (100 kHz – 20 GHz) and an array of switched harmonics (low pass) filters (150 MHz – 20 GHz)
- Doubler FD40 including the frequency doubler up to 40 GHz (optional)
- Doubler FD40P including the frequency doubler and high power amplifier up to 40 GHz (optional)

A detailed description of these modules is given in the next chapters.

3.1.2 Power Supply Module

The power supply module provides all necessary voltages for the operation of the signal generator. It can be switched on and off by means of the power switch on the rear panel. After switch-on, the instrument is either in standby or in operating mode, depending on a value stored in an internal EEPROM.

The power supply works over a wide input voltage range from 100 V to 240 V ($\pm 10\%$) and AC supply frequencies from 50 Hz to 60 Hz ($\pm 5\%$).

On the secondary side, the power supply generates three DC voltages (+5.0 V, +13.25 V, -13.25 V) and one standby voltage (+5 V), all $\pm 5\%$.

The secondary voltages are open-circuit-proof and short-circuit-proof with respect to ground and each other.

The power inlet module contains two fuses. Replace these fuses only with type and rating specified on the rear panel. If the replaced fuse blows again, change the module.

Further fuses are fitted on the BASIS BOARD as a means of fire protection.

In instruments equipped with option R&S SMB-B26 (Low Harmonic Filter) a power supply module with higher output power is installed.

3.1.3 Basis Board Module

The Basis Board of the signal generator involves the following components and modules.

3.1.3.1 Fuses

Each supply voltage is fused with one or several fuses on the Basis Board.

3.1.3.2 Switching regulators

The built-in switching regulators generate the additional supply voltages.

3.1.3.3 Controller

Central Controller of the R&S SMB including all memory devices and external interfaces.

3.1.3.4 FPGA (SMB_COM)

The SMB_COM FPGA contains the serial bus for internal communication of the instrument, timer functions, the display controller and the logic of the frequency counter.

3.1.3.5 Keyboard Controller

The keyboard controller notifies the processor about keyboard and spin wheel events. The keyboard controller switches on or off the power supply module and memorizes the power on state of the instrument when the main power is cut. This state is reconstituted on powering the instrument again.

3.1.3.6 Diagnostic ADC

The diagnostic ADC is used for measuring the voltages in the unit. These voltages are used for internal adjustments and the ALC S&H mode of the R&S SMB. Additionally the failure diagnostic of the instrument is carried out by the use of the Diagnostic ADC.

3.1.3.7 EEPROM

The following data is stored here: Serial number of the instrument, header line data of the board.

3.1.3.8 Temperature sensor

A temperature sensor mounted on the Basis Board monitors the temperature. If a defined temperature above the guaranteed maximum operating temperature is exceeded, the power supply is switched off. So the R&S SMB secures itself against damage due to overheating.

3.1.3.9 Fan Controller

Two fans for cooling the RF modules are connected to the BASIS BOARD and directly controlled according to the temperature of the Basis Board. This is done independent of the controller.

3.1.4 RF Board 13 Module

The RF-Board 13 contains the major part of the measuring hardware of the instrument. The RF and LF signals are generated and modulated on the module. The output level of the RF-Board 13 is controlled by a level control loop.

The following diagram shows the main RF functional blocks of the board.

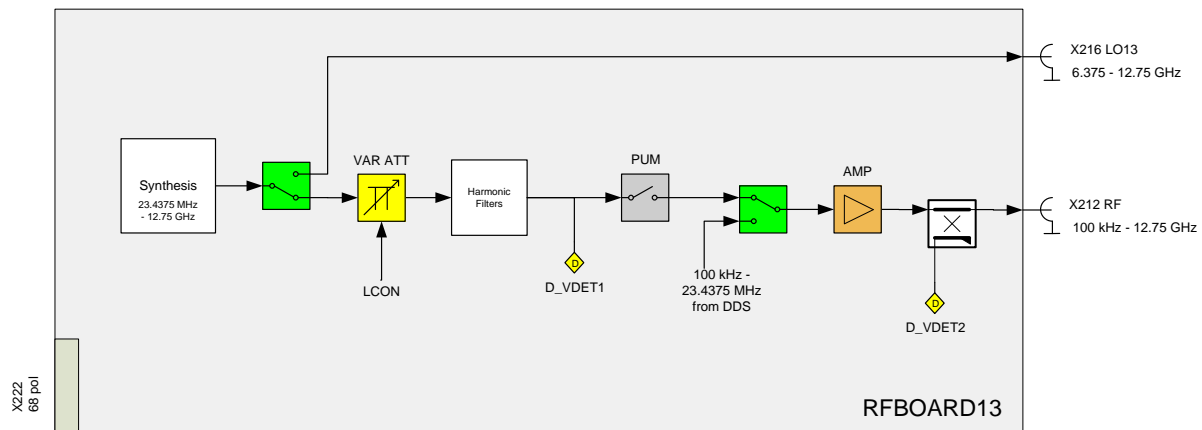

3.1.4.1 Implemented functions

- Reference crystal oscillator and reference frequency switch
- Synthesizer
- Frequency doubler
- LF generator
- Pulse generator and Pulse modulator control
- Modulation matrix
- DDS module including AM/FM/ ϕ M modulator
- AM modulator
- Harmonics filters
- Pulse modulator
- RF amplifiers
- Level control
- Diagnostics

3.1.4.2 Internal and external 10 MHz reference

The instrument's reference frequency is determined either by the signal supplied by the built-in OCXO (A210 reference oscillator) or by an external 10 MHz reference signal that is fed to the input X201 REFIN. The output X202 REFOUT provides a buffered 10 MHz signal, which has been derived from the active reference source. In internal reference mode, the frequency of the OCXO can be adjusted by a DAC.

3.1.4.3 TCXO 200 MHz crystal oscillator

A built-in 200 MHz TCXO delivers the internal reference signal for the DDS based Synthesizer and LF generator. This TCXO is synchronized to the selected 10 MHz reference signal (internal OCXO or externally applied signal) with a PLL.

3.1.4.4 RF Synthesizer/ DDS module

The 200 MHz signal of the TCXO provides the system clock for the DDS module. The RF output frequencies from 100 kHz to 23.4375 MHz are generated directly by the DDS. In this mode, any modulation is implemented in the digital domain. The modulated signal is converted to the analog domain by a DAC. The analog RF signal is then low pass filtered, amplified and fed to the input of the power amplifier.

For set frequencies above 23.4375 MHz the DDS generates a signal with high resolution, that is upconverted with the 200 MHz Signal from the TCXO and then applied as reference signal to the main PLL of the RF frequency synthesizer. In the synthesizer a VCO is locked to the reference frequency using a fractional-n-PLL. The VCO RF output signal ranges from 3000 ... 6375 MHz. Below 3 GHz it is fed to fixed frequency dividers which are set to appropriate divider ratios to generate the RF signal from 23.4375 MHz to 3 GHz. Frequencies above 6375 MHz are generated by doubling the fundamental VCO output frequency.

3.1.4.5 Harmonic filters

The output signal of the frequency dividers is a square wave signal. To reach the guaranteed harmonic performance (see datasheet) the harmonics of the RF signal have to be suppressed. Due to the wide RF frequency range multiple filters are needed. The different filters are selected according to the RF output frequency and their cut off frequency.

3.1.4.6 Band-pass filters

The output signal of the frequency doubler also contains the fundamental VCO frequency and its harmonic components which have to be suppressed by band-pass filters.

3.1.4.7 LO output

The RF-Board 13 provides an LO output signal at X216 LO13 which serves as input signal for the 20 GHz frequency option.

3.1.4.8 LF generator

The above mentioned DDS module also generates the LF sine wave or square wave signal. This signal can be used as a source for internal modulation or as output signal at LFOUT BNC connector for frequencies up to 1 MHz in sine wave mode or up to 20 kHz in square wave mode. The output amplitude of the LF signal is set with a multiplying DAC in the range from 1 mV to 3 V.

3.1.4.9 Pulse Generator and Pulse Modulator

The pulse generator is also digitally implemented in the DDS module (FPGA). The pulse generator has three different modes. The pulse generator can run free, can be triggered or gated externally using the PULSE EXT input. The input impedance at the PULSE EXT BNC connector can be chosen high-impedance or 50 Ω . The pulse signal serves as a source for internal pulse modulation and can additionally be applied at the output PULSE/VIDEO in a buffered way.

Below 23.4375 MHz the pulse modulator is implemented digitally switching on and off the output signal of the DAC. Above 23.4375 MHz four RF switches in series are used as pulse modulator.

3.1.4.10 Modulation matrix and AM/FM/φM modulator

The external modulation signal from MODEXT can be AC- or DC-coupled. This signal is converted into the digital domain by the means of a 12 Bit ADC. The Frequency and Phase Modulations are implemented fully digital in the DDS module. For output frequencies below 23.4375 MHz the AM is implemented fully digital as well. For RF frequencies above 23.4375 MHz, the modulation signal is applied as reference signal to the level control loop. The AM modulation depth is set by a multiplying DAC. A switch matrix to select internal, external or internal + external modulation signals is implemented in analog circuitry and additionally in the digital domain. For RF frequencies from 23.4375 MHz to 375 MHz a variable gain differential amplifier and above 375 MHz a PIN modulator is used as AM modulator in the RF path.

3.1.4.11 Power Amplifiers

To achieve high output power levels over the entire frequency range, the power amplifier is split into two frequency bands.

3.1.4.12 Automatic Level control

A small part of the RF output power is coupled to an RF detector. The output signal of this RF detector is fed to the Automatic Level Control (ALC) unit. The ALC sets the Level Control Voltage driving the amplitude modulator to reach the desired output level.

In case of setting the ALC into the OFF state, the level is actually still controlled by the levelling loop, using another RF detector before the pulse modulator.

Levelling for any installed frequency option is done only on the RF-Board 13. This requires the RF-Board to have an external detector voltage input (X217 VDET20) and a level control output (X218 LCON20).

The following diagram shows the basic functionality of the ALC.

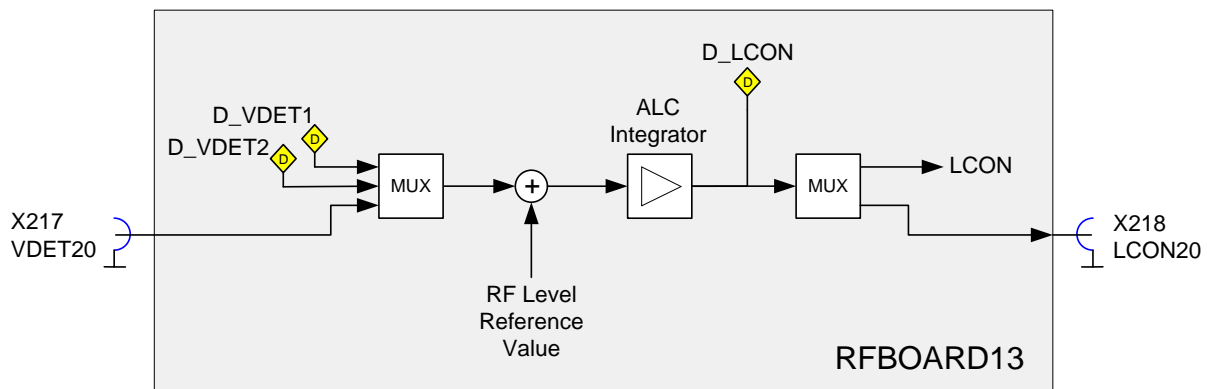

3.1.4.13 Supply voltage control and filtering

The module supply voltages are filtered by means of passive filtering and additional active voltage regulators. Linear regulators with very good noise and distortion suppression characteristics have been implemented based on operational amplifier circuitry.

3.1.5 Reference Oscillator Module

The frequency stability (temperature drift and aging) and the phase noise performance close to the carrier (< 100 Hz offset frequency) of the instrument is improved by option R&S SMB-B1/B1H Reference Oscillator. The option is plugged into the RF-Board module at the rear panel of the instrument. See chapter [Replacing the Reference Oscillator Option R&S SMB-B1/B1H \(A210\)](#).

3.1.6 Active Step Attenuator Module

The dynamic range of output power from the RF Board is limited due to several technical restrictions. Therefore the Active Step Attenuator is used to extend the output power range of the instrument. To gain very low output levels an attenuator can be switched in 6 dB-Steps to approximately 120 dB. To achieve high output power levels a power amplifier is integrated on the module.

The following diagram shows the functional principle.

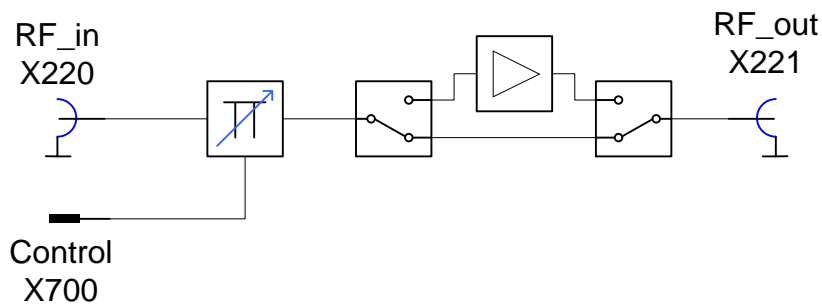

3.1.6.1 Implemented functions

- Switching Matrix
- Power Amplifiers
- Voltage Regulators and filtering

3.1.6.2 Switching matrix

The switching matrix consists of two parts. At the input the minor steps from 6 to 24 dB and near the output the major steps 24, 30, 30 dB. Directly at the output there is one 6 dB attenuator to ensure stable output VSWR over a wide range of settings.

3.1.6.3 Power Amplifiers

To offer high output power levels despite of the insertion loss of the switching matrix there are two amplifiers which can be switched into the path at the output of the board. The amplifiers are split into frequency bands. There is one for the low frequencies from 1 MHz to 8 GHz and one for the range from 6 GHz to 12.75 GHz.

3.1.6.4 Voltage Regulators and filtering

There are two voltage regulators located at the board connector as the Step Attenuator is used in multiple instruments with different supply voltages. On the board itself great efforts have been spent to effectively filter all control voltages to ensure the requested dynamic range.

3.1.7 Reverse Power Protection Module

At the RF output of the R&S SMB a reverse power protection circuitry detects RF power and DC voltage fed into the RF socket from outside the instrument. To protect the R&S SMB against damage a relay and an electronic circuitry disconnects the RF output, when a reverse power of more than approximately 30 dBm is detected. In standby or power off mode this relay is also in off state to protect the RF output of the instrument from damage.

3.1.8 RFBOARD20 Module

The RFBOARD20 is a frequency extension module for the R&S SMB100A signal generator which provides frequencies up to 20 GHz at its output. The module contains the necessary functions for signal generation and modulation of a frequency octave band. The signal chain consists of the following function blocks: Frequency doubler, band pass filters, variable attenuator, pulse modulator, signal amplifiers and frequency band switches.

The block diagram illustrates the functionality of the RFBOARD20:

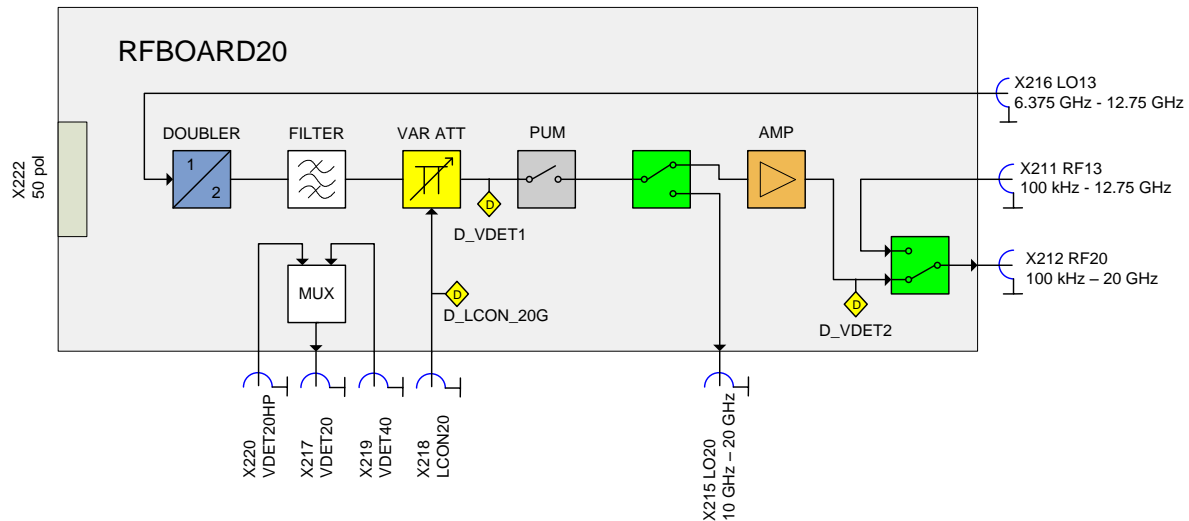

3.1.8.1 Implemented functions

- Frequency doubler
- Band pass filters
- Variable attenuator
- Pulse modulator
- Signal amplifiers
- Frequency band switches
- Level control hardware
- Digital control and diagnostics

3.1.8.2 Frequency doubler

The frequency doubler function block uses the synthesized local oscillator signal from the RF Board 13 for the generation of frequencies up to 20 GHz. Angle modulated signals are passed through the frequency doubler.

3.1.8.3 Band pass filters

The band pass filters account for the signal purity of the output signal. After frequency doubling the spectrum is filled with a number of harmonics of the fundamental. The filters suppress the sub-harmonics and pass through the desired output signal. The appropriate filter is selected according to the RF output frequency.

3.1.8.4 Variable Attenuator

The level of the output signal is adjusted by a variable attenuator. This attenuator is controlled by the automatic level control (ALC) circuitry located on the RF Board 13. Amplitude modulation of the output signal is accomplished by the variable attenuator.

3.1.8.5 Pulse Modulator

The pulse modulator is used for switching the output RF signal on and off. The switching is implemented with a high on / off ratio and short rise / fall times of the RF output signal. The pulse modulator is driven by the pulse generator on the RF Board 13 module. Two signals can switch the pulse modulator PUM to high attenuation: One controls the PUM during modulation and one is applied when blanking of the RF signal is required.

3.1.8.6 Signal Amplifiers

Signal amplifiers are used throughout the RF signal chain in order to compensate transmission loss and provide the desired output level.

3.1.8.7 Frequency band switches

Frequency band switches route the signals of several frequency ranges: One switch combines the lower and the higher frequency paths in order to generate one broadband signal path. A second switch provides a octave band signal for further frequency extension modules.

3.1.8.8 Level control hardware

Several analog control signals are employed by the automatic level control ALC circuitry. The signal LCON20 at connector X218 is the actuating variable of the ALC which sets the variable attenuator directly. The feedback signal to the ALC is VDET20 at connector X217. A multiplexer on the module selects the feedback variable between internal detector signals, the detector signal from HP20 module VDET20HP at X220 or the detector signal from the FD40 / FD40P module VDET40 at X219.

3.1.8.9 Digital control and diagnostics

There is a digital serial bus system in the instrument which is used to control the modules via software. Digital logic on the module decodes the messages and controls the hardware. Electronic diagnostics is implemented on the module which is used to measure voltages on certain nets.

3.1.9 HP20 Module

The HP20 is a broadband amplifier module for the R&S SMB100A signal generator which provides high output power for signal frequencies up to 20 GHz at its output. The signal chain consists of the following function blocks: Broadband high power amplifiers, switches.

The block diagram illustrates the functionality of the HP20:

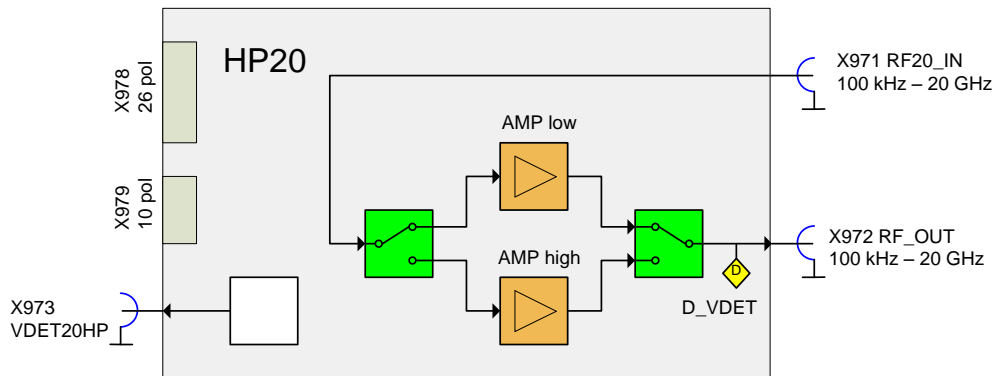

3.1.9.1 Implemented functions

- Broadband high power amplifiers
- Level control hardware
- Digital control and diagnostics

3.1.9.2 Broadband high power amplifiers

Several broadband amplifiers provide high power signals at the module output over the whole frequency range. One path amplifies lower frequency signals and one path amplifies the higher frequency signals. Switching between the two paths is done at approximately 3 GHz.

3.1.9.3 Level control hardware

There is a level detector at the output of the module. The detector signal VDET20HP is provided at X973, is fed to the RFBOARD20 and is used by the ALC circuitry.

3.1.9.4 Digital control and diagnostics

There is a digital serial bus system in the instrument which is used to control the modules via software. Digital logic on the module decodes the messages and controls the hardware. Electronic diagnostics is implemented on the module which is used to measure voltages on certain nets.

3.1.10 FILTER20 Module

The FILTER20 is a broadband amplifier and harmonics filter module for the R&S SMB100A signal generator which provides high output power and harmonics suppression to -50..-60 dBc for signal frequencies up to 20 GHz at its output. The signal chain consists of the following function blocks: Broadband high power amplifiers, switches, switchable low pass filters.

The block diagram illustrates the functionality of the HP20:

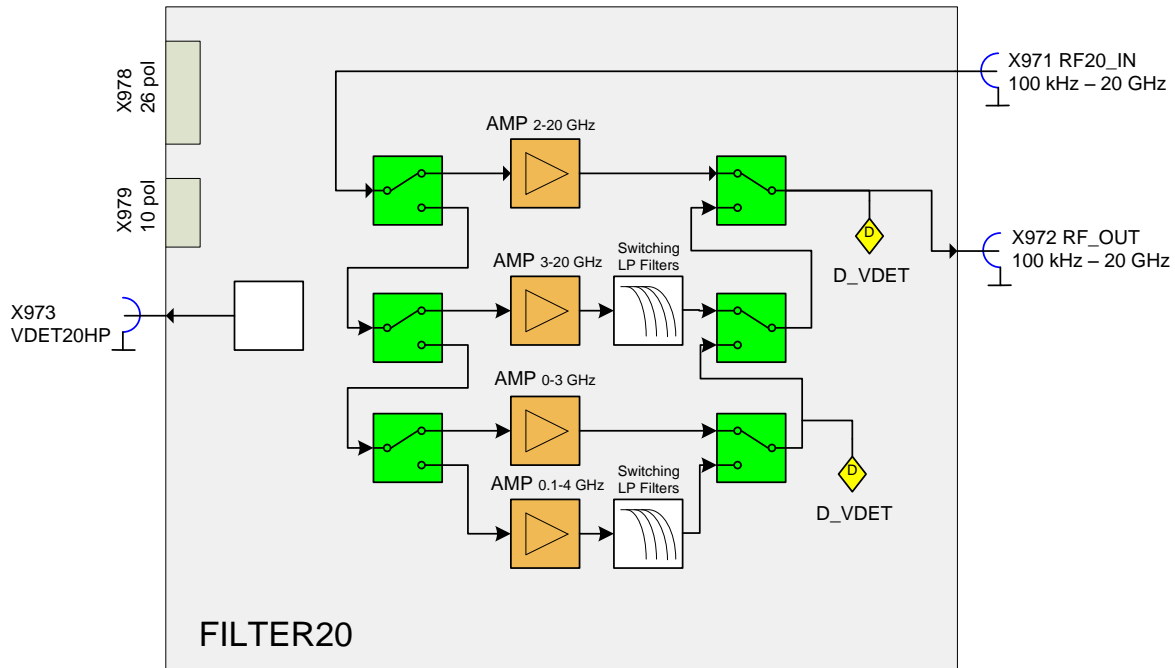

3.1.10.1 Implemented functions

- Broadband high power amplifiers
- switchable low pass filters
- Level control hardware
- Digital control and diagnostics

3.1.10.2 Switchable low pass filters

Various low pass filters are employed to remove unwanted K2 (K3, ...) harmonics from the spectrum. Two groups of filters are used in this module. Printed circuit low pass filters are connected to the output of one of the high frequency amplifiers. The other group of filters (discrete, switchable) are connected to the output of one of the low frequency amplifiers.

The other two of the amplifiers – bypassing the low pass filters – are used for the high output power mode of the FILTER20 module.

3.1.10.3 all other functions

See HP20 Module.

3.1.11 FD40 / FD40P Module

The FD40 / FD40P is a frequency extension module for the R&S SMB100A signal generator which provides frequencies up to 40 GHz at its output. The FD40P module delivers higher output power than the FD40 module. The modules contain the necessary functions for signal generation of a frequency octave band. The signal chain consists of the following function blocks: Frequency doubler, band pass filters, signal amplifiers and frequency band switch.

The block diagram illustrates the functionality of the FD40 / FD40P:

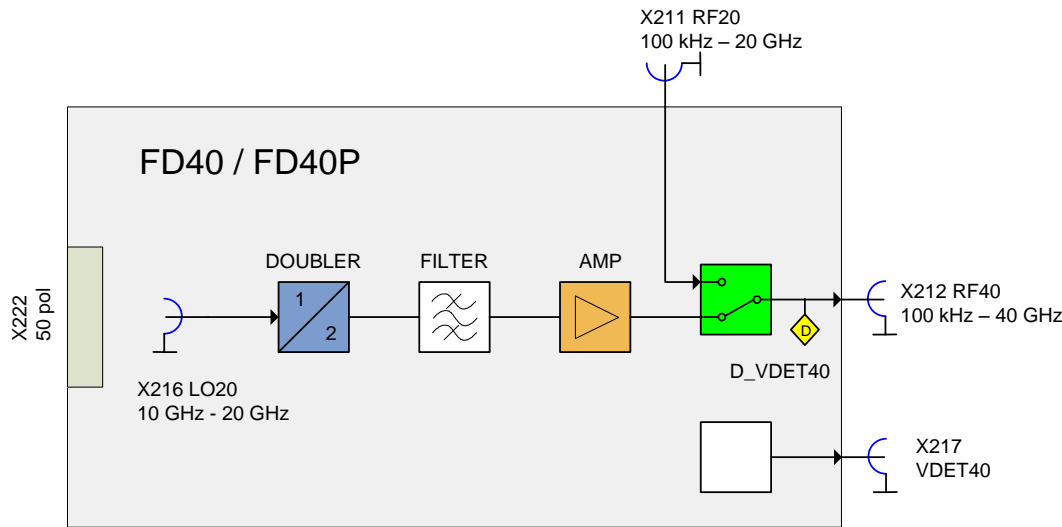

3.1.11.1 Implemented functions

- Frequency doubler
- Band pass filters
- Signal amplifiers
- Frequency band switch
- Level control hardware
- Digital control and diagnostics

3.1.11.2 Frequency doubler

The frequency doubler function block uses the synthesized local oscillator signal from the RFBOARD20 for the generation of frequencies up to 40 GHz. Angle modulated signals are passed through the frequency doubler.

3.1.11.3 Band pass filters

The band pass filters account for the signal purity of the output signal. After frequency doubling the spectrum is filled with a number of harmonics of the fundamental. The filters suppress the sub-harmonics and pass through the desired output signal. The appropriate filter is selected according to the RF output frequency.

3.1.11.4 Signal Amplifiers

Signal amplifiers are used throughout the RF signal chain in order to compensate transmission loss and provide the desired output level.

3.1.11.5 Frequency band switch

A frequency band switch combines the lower and the higher frequency paths in order to generate one broadband signal path.

3.1.11.6 Level control hardware

There is a level detector at the output of the module. The detector signal VDET40 is provided at X217, is fed to the RFBOARD20 and is used by the ALC circuitry.

3.1.11.7 Digital control and diagnostics

There is a digital serial bus system in the instrument which is used to control the modules via software. Digital logic on the module decodes the messages and controls the hardware. Electronic diagnostics is implemented on the module which is used to measure voltages on certain nets.

3.1.12 ATT40 Module

The ATT40 module is a mechanical step attenuator. The attenuator is controlled digitally and is used to generate low power output signals over whole frequency range.

The block diagram illustrates the functionality of the ATT40:

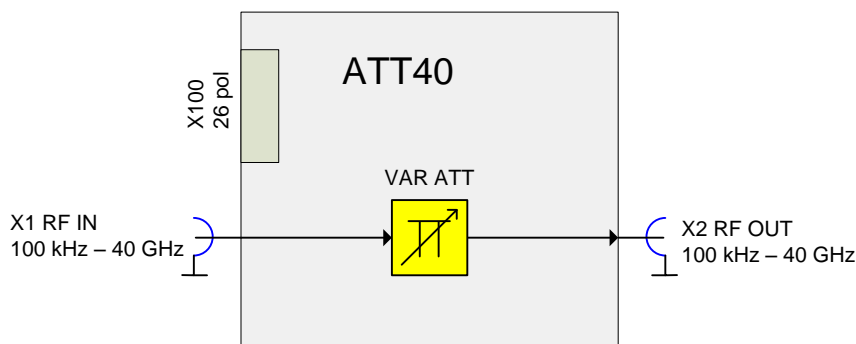

3.1.12.1 Implemented functions

- Step attenuator
- Digital control and diagnostics

3.1.12.2 Step attenuator

Several elements with different attenuation values are connected in series in order to reduce the signal level over high and scaleable range.

3.1.12.3 Digital control and diagnostics

There is a digital serial bus system in the instrument which is used to control the modules via software. Digital logic on the module decodes the messages and controls the hardware.

Electronic diagnostics is implemented on the module which is used to measure voltages on certain nets.

3.2 Troubleshooting - Instrument

The purpose of these troubleshooting instructions is to help to trace down malfunctions to board level. The instrument can thus be made ready for use again by means of board replacement.

If error tracing doesn't show clear results, we recommend that you ship your instrument to our experts in the service centers (see address list) for module replacement and further error elimination. Some module replacements involve calibration procedures requiring calibrated equipment and appropriate software.

⚠ DANGER**Danger of shock hazard**

For module replacement, ensure that the instrument is switched off and disconnected from the power supply by removing the plug from the AC and DC power connector.

Read all safety instructions at the beginning of this manual carefully before module replacement.

NOTICE**Risk of damage to the boards**

Be careful not to cause short circuits when measuring voltages at pins placed close together.

The following utilities are provided in the signal generator for easy diagnosis:

- Internal selftest
 - Internal diagnosis test points
 - Internal adjustments
 - Info line with error messages and history of messages
 - Internal keyboard test
-



When problems occur, first check whether any connections (cables, plug-in connections of boards, etc) are damaged or wrongly connected.

3.2.1 Measuring Equipment and Accessories

Item	Type of equipment	Specifications recommended	Equipment recommended	R&S order No.
1	DC voltmeter		R&S URE	0350.5315.02
2	Spectrum analyzer	Frequency range 100 kHz to 40 GHz	R&S FSV40	1307.9002.40
3	Adapting cable	1 m long SMP-to-SMA connection	-	1129.8259.00
4	Oscilloscope	100 MHz	TDS 220	

3.2.2 Switch-On Problems

The yellow LED on the front panel, next to the ON/OFF Button is directly connected to the Standby Voltage of the power supply (via a resistor on the Basis Board) and is therefore a good indicator of the basic working of the power supply.

When the instrument is switched on, the following modules are involved:

- Power supply
- Basis Board
- Switching pad

To analyze switch-on and switch-off problems that occur with the R&S SMB, the interplay of the individual modules is summarized in the following.

3.2.2.1 Switch-on

When the ON/OFF button on the front panel is pressed, the signal on the ON/OFF test point (see [Fig. 3-3](#)) goes low. In this case the Basis Board pulls the signal on pin 13 of X101 (power supply connector see [Fig. 3-4](#)) low, which in turn switches on the power supply. In case of a prior emergency shutdown (pressing the ON/OFF Button for more than 5 seconds) it may take a few seconds until this mechanism works again.

Within four seconds after switch-on, the CPU takes over the control of pin 13 of the power supply connector. If the green LED on the front panel lights up for only a short time (approx. five seconds) and then the orange standby LED lights up again, this means that the CPU is not booting properly. The cause may be a defective or overheated power supply or Basis Board.

- **Error: Instrument cannot be switched on.**

Action	Possible error causes and further steps
Check power-on switch on the rear. Check fuses on the rear. ↓	Power switch OFF: Switch on power supply.
Check yellow LED (standby). ↓	LED remains unlit: Measure standby voltage at pin1 X101. Rated value: 4.75 V... 5.25 V No voltage: Check power cable from power supply. no/faulty voltage: change power supply Otherwise: Loose Cable W112 or bad contact of switching pad.

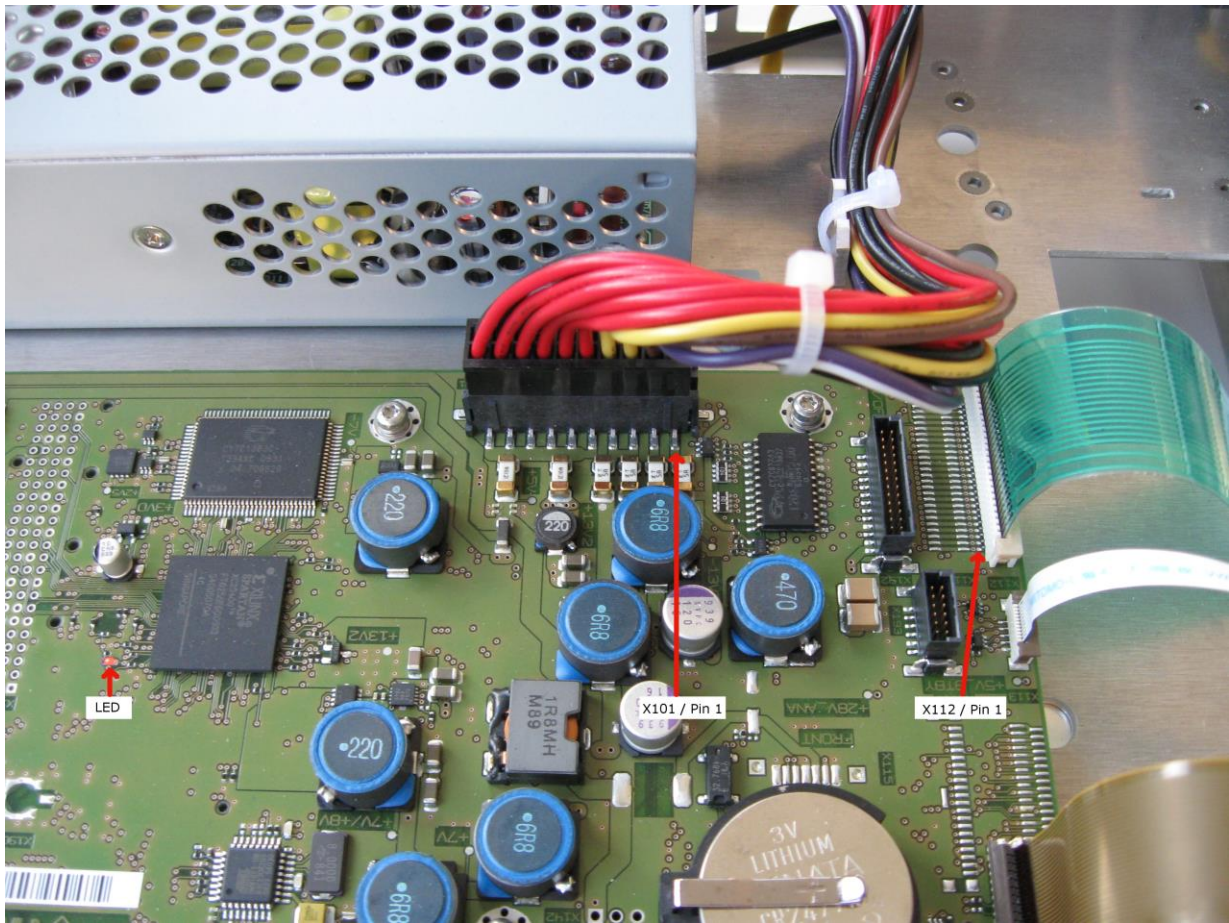

Fig. 3-4 LED, X101 and X112 location on the Basis Board

- **Error: Signal generator starts up but display remains black**

Description of error	Possible error causes and further steps
CPU does not boot correctly	<ul style="list-style-type: none"> ➤ Check red LED on Basis Board (see Fig. 3-4). <p>If LED does not turn red approx. 1 sec after power on, either the Basis Board FPGA does not configure correctly or the CPU does not boot.</p> <p>Change Basis Board</p>
Cables are loose	<ul style="list-style-type: none"> ➤ Check cabling between Basis Board and Display
TFT display defective	<ul style="list-style-type: none"> ➤ Replace Front panel with TFT display

- Error: Fan does not work

Description of error	Possible error causes and further steps
Fan does not work	<p>Disconnect fan and check voltages on BASIS BOARD X116 and X1116 (fan connectors) between pin 1 and 2. Rated voltage: 8 V ... 13 V, depending on temperature.</p> <p>Correct voltage: Replace fan</p> <p>Faulty voltage: Check the power supply of the Basis Board (see page 3.32).</p>

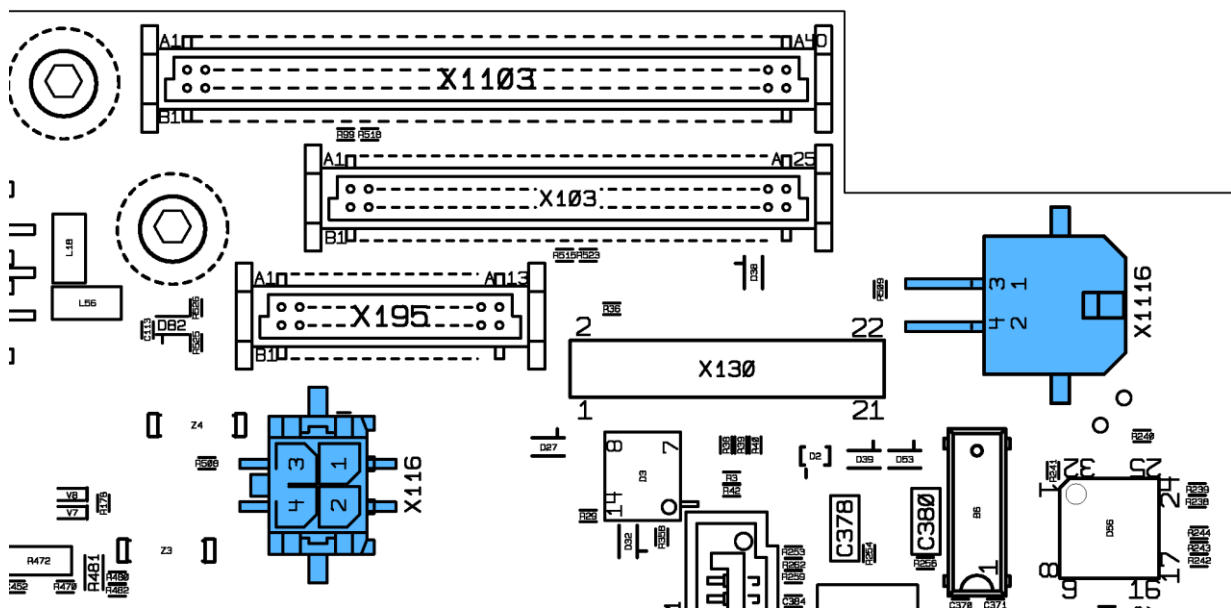

Fig. 3-5 X116 and X1116 Fan Connector Pin Location

3.2.2.2 Switch-off

Besides pressing the power switch, the instrument can be switched off in three ways.

After briefly pressing the ON/OFF button on the front panel, the CPU performs a normal system shutdown and then powers off the power supply via pin 13 of the power supply connector.

Pressing and holding the button on the front panel for longer than five seconds leads to an emergency shutdown, which is controlled by special hardware on the Basis Board. In this case, no user data can be saved.

The instrument can also be switched off by means of the temperature monitoring circuit on the Basis Board. If the temperature sensor on the Basis Board detects an over temperature (e.g. in the event that a fan fails), the power supply is switched off via pin 13 of the power supply connector. It can only be switched on again, after cooling down.

3.2.3 Problems with Booting

- **Error: Unit does not start the application**

After switch-on, the signal generator first runs the Boot Loader. The Boot Loader displays the R&S Logo. The Boot Loader loads the FPGA on the Basis Board. After successful initialization of the computer (approx. 10 seconds), the LINUX operating system starts up and displays the background picture. Subsequently, the application is loaded. During loading, several progress bars are shown on the display.

All software of the R&S SMB is stored in an on board flash memory. There are no serviceable hardware parts related to mass memory. The only possible service action is the reinstallation of firmware, which requires at least some basically working computer and firmware.

Normal action	Error, possible causes and corrective action
<ul style="list-style-type: none"> ➤ Start signal generator 	<p>R&S Boot Screen does not disappear</p> <p>Error: The operating system (LINUX) does not start.</p> <p>Reinstall the firmware of the device. If this does not solve the problem, replace the Basis Board.</p>



Fig. 3-6 R&S Boot Screen

3.2.4 Keyboard and Rotary Knob Test

- This **utility** allows you to check for proper operation of all front panel control elements

Normal action	Error, possible causes and corrective action
<p>Test called with SETUP - Check Front Panel...</p> <p>An image of the front panel appears with gray keys.</p> <p>When a key is pressed once or the knob is moved, the field changes to green.</p> <p>If the key is pressed more than once, the field changes to red.</p>	<p>Note:</p> <p>Be careful with the rotary knob! Turn only slightly in the specified direction; otherwise the field will change to red.</p>

Normal action	Error, possible causes and corrective action
<p>When all operating elements including the rotary knob have been actuated once, all fields are green. If operating elements have been actuated twice, the fields are red.</p>	<p>If the color changes to red at the first actuation, a malfunction has occurred (bouncing). If the color of the corresponding field remains the same after actuation, the function is defective.</p> <p>In either case: Change the switching pad and/or rotary knob.</p>
<p>A message is output when all keys have been pressed: "All Front Panel Keys were accessed correctly"</p>	<p>Note: No error message is output even if a number of keys are red. The user must decide whether a malfunction has occurred.</p>

3.2.5 USB Cable Test

USB cables of good quality are required for EMI suppression and stable connections.

However, according to our experience USB cables are of varying and often poor quality. This concerns the connection between the cable shield and the shield contacts of the connectors.

Cables of poor quality may cause EMI interference and poor connection quality. EMI interference, among other things, may ultimately lead to measurement errors. Poor connection quality may create problems like increased latencies that are due to retransmissions because of data corruption or may even lead to a complete loss of data connection.

Therefore, we recommend checking every USB cable using the following easy method:

Measure the electrical resistance from the shield contact of one connector to the shield contact of the other connector. For correct measurement results, consider the contact resistance at your probe tips. Good cables have a value of less than 0.6 Ω according to USB standards.

Also check, whether the resistance is stable when you bend the cable.

3.2.6 Troubleshooting with Internal Selftest

The internal selftest checks the instrument by setting different internal states and measuring internal diagnostic voltages. The selftest is subdivided into the mounted hardware modules/options. Each module is set to several conditions and the diagnostic voltages are measured in each case. The measured values are compared with limits in order to judge the functionality.

Execute **SETUP - Selftest- Start Selftest** . The selftest reports the modules stating irregular values:

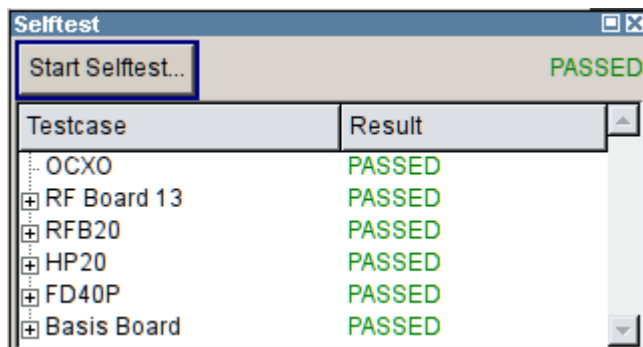

To see the details of the selftest open the corresponding branch of the result tree:

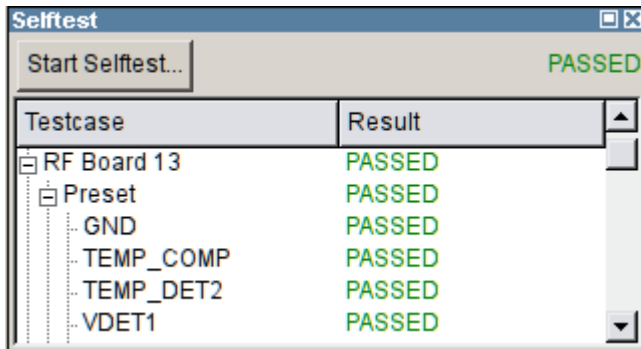

If the selftest fails on one module, this does not directly imply the specific module to be defective (and vice versa), as results may be ambiguous in some combinations of installed options (RF Board with Step Attenuator with/without Reverse Power Protection).

It is not possible to verify RF performance within the modules diagnosis; external equipment is needed.

3.2.7 Troubleshooting with Internal Adjustments

Various internal adjustments are necessary for correct operation of the instrument. The failure of a certain adjustment can shorten troubleshooting considerably.



Failed internal adjustments can also be queried on the info page -> History.

Normal action	Error, possible causes and corrective action
Internal adjustments call: SETUP - Internal Adjustments - Adjust All Internal adjustments of the installed modules are executed.	Abort during adjustment: Internal synthesis adjustment is carried out on the RF Board 13, the diagnostic A/D converter on the Basis Board is needed. Checking more diagnostic voltages on the RF Board 13 helps isolating the defective module / cable. Internal level adjustment is carried out on all installed RF modules. Several parameters are determined which are necessary for correct level setting. Executing the instruments selftest helps isolating the defective modules / cables.

3.2.8 Instrument Faults

Following the previous examinations it is very likely that one or several faults on one or several RF modules are responsible for the poor RF performance, e.g. wrong RF level or frequency, bad spectral purity or faulty modulation. The flow chart below helps to narrow down the source of the failure to module level and associated cabling dependent of the frequency range with poor RF performance (faulty range). If a failure can be recognized within the stated faulty range one should check the modules listed on the right with descending priority. The module checks are described in the subsequent chapters.

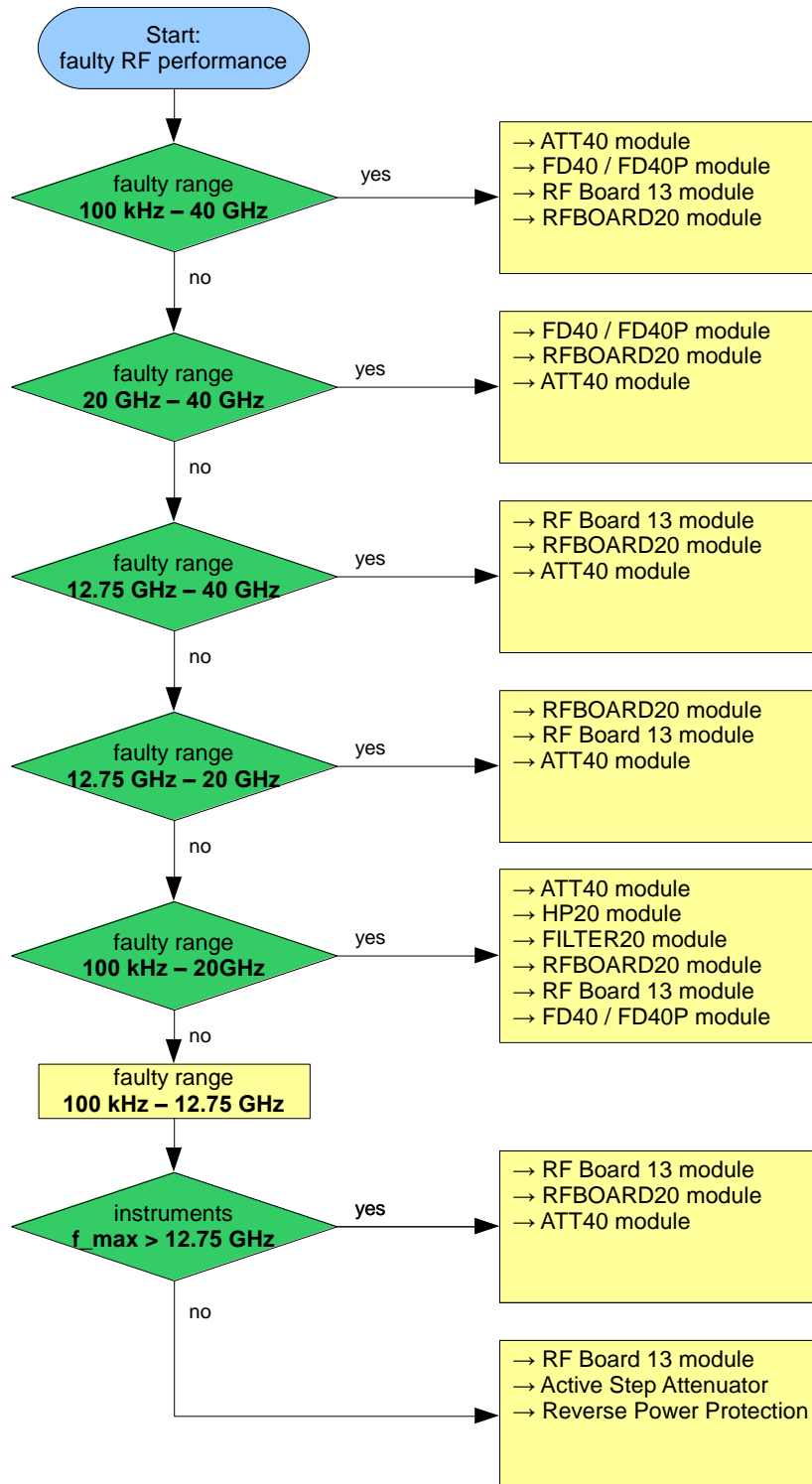

The following table lists R&S SMB faults. For every fault additional test are described to determine the defective module.

Fault	Test	Action if test fails
RF Output Level is wrong	R&S SMB settings: <ul style="list-style-type: none"> • Instrument Preset • Reference internal • RF on • Level = 15 dBm Measure the Output Level with a power meter across the frequency range. The difference between set and measured level has to be lower than guaranteed in the datasheet.	Check the mating torque of the screw-in connectors at all semi-rigid cables (depending on mounted RF options) being 60 Ncm for system SMA and 90 Ncm for system K (2.92mm). The flow chart above helps to trace the source of failure to board level.
RF Output Frequency is wrong	R&S SMB settings: <ul style="list-style-type: none"> • Instrument Preset • Setup ➔ Adjustment ➔ 'Adjust all' • Setup ➔ Reference external • RF on • Level: 0 dBm • Frequency = 1 GHz Supply an external 10 MHz reference signal meeting the level and frequency specification given in the datasheet. Measure output frequency with a spectrum analyzer or a frequency counter synchronized to the same reference. The frequency error has to be < 0.1 Hz.	Most probably the RF Board 13 is defective. Check the RF Board being supplied correct (see page 3.34).
	R&S SMB setting: <ul style="list-style-type: none"> • Setup ➔ Reference internal Measure the 10 MHz reference output signal with spectrum analyzer or frequency counter and power meter. Output frequency and level have to meet the specifications given in the data sheet.	Without Reference Oscillator R&S SMB-B1/B1H being equipped most probably the RF Board is defective. Check the RF Board 13 being supplied correct (see page 3.34). If the R&S SMB is equipped with Reference Oscillator R&S SMB-B1/B1H remove the unit (see page 3.71) and perform this test again. If it works most probably the Reference Oscillator B1/B1H is defective. Check the Reference Oscillator being supplied correct (see page 3.34).

Fault	Test	Action if test fails
<p>Poor Harmonic Distortion</p>	<p>R&S SMB settings:</p> <ul style="list-style-type: none"> • Instrument Preset • Reference internal • RF on • ATT-Mode Auto • Level = Maximum guaranteed level for harmonic distortion (see datasheet) <p>Measure the level of the fundamental frequency and its harmonics with a spectrum analyzer over the whole frequency range. The allowed maximum level of the harmonics is stated in the datasheet. Comment: In ATT-Mode fixed harmonic distortion is not guaranteed above Levels displayed under 'Level' menu ➔ 'Attenuator Settings' ➔ 'Fixed Range in'.</p>	<p>The flow chart above helps to trace the source of failure to board level.</p>
<p>Poor Harmonic Distortion (Option B25 / B26 installed)</p>	<p>Check if performance is out of spec below or above 20 GHz.</p> <p>Check if harmonic performance is out of spec in LowHarmonicsMode (e.g. -55 dBc) or in the HighPower range (e.g. -30 dBc).</p>	<p>LowHarmonics mode out of spec for $f < 20$ GHz ➔ replace <i>Filter20</i> module</p> <p>LowHarmonics mode out of spec for $f > 20$ GHz ➔ replace <i>FD40P</i> module</p> <p>HighPower range out of spec for $f < 20$ GHz ➔ most likely <i>Filter20</i> is defective, but a problem with <i>RFBoard20</i> or <i>RFBoard13</i> is also possible.</p>
<p>Reverse Power protection does not trigger (for instruments equipped with R&S SMB-B30)</p>	<p>Make sure that option R&S SMB-B30 is installed.</p> <p>Switch on RF -> apply a DC voltage step from 0 to +12 V to the RF connector of the R&S SMB.</p>	<p>If RF output is not switched off and an error message appears the Reverse Power Protection is defective. Check the Reverse Power Protection being supplied correct,</p>
<p>Slow Settling times</p>	<p>Settling times are defined for GPIB remote control only. The settling time is the time-delay after asserting EOI until level and frequency are within the given tolerance from their final values.</p> <p>Be careful not to measure with an instrument drifting on its own due to applying the RF from the R&S SMB.</p>	<p>The flow chart above helps to trace the source of failure to board level</p>

Fault	Test	Action if test fails
10 MHz Reference Input faulty	<p>Check the 10 MHz reference signal fed into the R&S SMB with a spectrum analyzer or frequency counter and power meter. If level and frequency of this signal is matching the specification in the datasheet set the R&S SMB to:</p> <ul style="list-style-type: none"> • Instrument Preset • Reference external • RF on • Frequency = 1 GHz • Level = 0 dBm <p>Check for error Messages. No "External Reference Errors" are allowed to occur. Measure output frequency with a spectrum analyzer or a frequency counter synchronized to the same reference. The frequency error has to be < 0.1 Hz.</p>	Most probably the RF Board 13 is defective. Check the RF Board being supplied correct (see page 3.34).

Fault	Test	Action if test fails
<p>10 MHz Reference Output faulty</p>	<p>R&S SMB setting:</p> <ul style="list-style-type: none"> • Setup ➔ Reference internal <p>Measure 10 MHz reference output signal with spectrum analyzer or frequency counter and power meter. Output frequency and level have to meet the specifications given in the data sheet.</p>	<p><i>R&S SMB without Reference Oscillator R&S SMB-B1/B1H:</i> Most probably the RF Board is defective. Check the RF Board being supplied correct (see page 3.34).</p> <p><i>R&S SMB with Reference Oscillator R&S SMB-B1/B1H:</i> Remove the Reference Oscillator (see page 3.71) and perform this test again. If still failing most probably the RF Board 13 is defective. Check the RF Board being supplied correct (see page 3.34). If the 10 MHz reference signal is in tolerance most probably the Reference Oscillator B1/B1H is defective. Check this module being supplied correct (see page 3.40).</p>
<p>LFGGen Output faulty</p>	<p>R&S SMB settings:</p> <ul style="list-style-type: none"> • LFGGen Stat on • LFGGen Source Impedance Low • LFGGen Freq 50 Hz <p>Measure the output voltage of the LF signal output with an AC-multimeter. The RMS reading should be $0.707\text{ V} \pm 0.05\text{ V}$.</p>	<p>Check the connection of cable W215 to the RF Board 13 (see Removing the RF-Board). If it is connected correct most probably the RF Board 13 is defective. Check the RF Board 13 being supplied correct (see page 3.34).</p>
<p>MOD ext Input faulty</p>	<p>R&S SMB settings:</p> <ul style="list-style-type: none"> • Setup ➔ Reference internal • AM State on • AM Source external • Ext Impedance High <p>Measure the input resistance of the Mod Ext BNC connector signal with a multimeter. The input resistance should be $221\text{ k}\Omega \pm 20\%$.</p>	<p>Check the connection of cable W214 to the RF Board (see Removing the RF-Board). If connected correct most probably the RF Board 13 is defective. Check the RF Board being supplied correct (see page 3.34).</p>

Fault	Test	Action if test fails
Amplitude Modulation faulty	<p>The AM is specified only up to the Peak Envelope Power (PEP) noted in the datasheet. The PEP value of an AM signal with depth m at setting level P is</p> $P_{PEP} = \text{Level} + 20 \log_{10}(1 + m/100)$ <p>So at m = 100 % the PEP is 6.02 dB higher than the setting level shown in the display. The AM performance has to match the values given in the datasheet. Measure with a true demodulating receiver, i.e. a R&S FSMR or R&S FSL/ FSP/ FSU/ FSQ spectrum analyzer equipped with option R&S-K7</p>	The flow chart above helps to trace the source of failure to board level
Frequency/ Phase Modulation faulty	<p>FM and PhiM Modulation are generated in the DDS synthesizer reference signal on the RF Board 13. Run Internal Adjustments to ensure the VCOs generating the RF signal working in their optimum. The FM performance has to match the values given in the datasheet. Measure with a true demodulating receiver, i.e. a R&S FSMR or R&S FSL/ FSP/ FSU/ FSQ spectrum analyzer equipped with option R&S-K7.</p>	Most probably the RF Board 13 is defective. Check the RF Board being supplied correct (see page 3.34).
Pulse Generator/ Pulse Modulator faulty	<p>The pulse generator is implemented fully digital in the RF Board FPGA. The pulse signals are fed to a pulse modulator on the RF Board 13 and to a modulator on the RFBOARD20. All external pulse-BNC connectors are fitted on the RF Board as well.</p>	Probably the RF Board 13 or the RFBOARD20 is defective. The flow chart above helps to trace the source of failure to board level
Signal Valid	<p>This signal is driven from the RF Board FPGA and the Signal Valid BNC connector is directly fitted onto the RF Board as well.</p>	Most probably the RF Board 13 is defective. Check the RF Board being supplied correct (see page 3.34).
Faulty Remote interface IEEE488, USB or LAN	<p>All remote interfaces including the interface connectors are fitted directly on the Basis Board.</p>	Most probably the Basis Board is defective. Check the Basis Board being supplied correct (see page 3.34).

3.2.9 Troubleshooting – Basis Board Module

3.2.9.1 Supply Voltages

Before Troubleshooting on the Basis Board switch the R&S SMB on and measure the supply voltages on its power supply connector (X101, see [Fig. 3-3](#) and [Fig. 3-4](#)) and compare them to the values specified in the table below. Pin 13 is the Power On-Signal for the power supply. As long as the voltage at this pin is +5 V the power supply is switched off. The power supply is turned on by assigning 0 V to this pin. If one or more voltages at the pins at X101 are not of the required level, the power supply is defective. If one or more of the other voltages X101 are not of the required level, the Basis Board is defective.

Pin at X101	Test Point	Fuse	R&S SMB in stand by mode	R&S SMB switched On
5...10	+5V	F4, F7	0 V	+4.7 V ... +5.3 V
3, 4	+13V2	F3, F5	0 V	+12.4 V ... +14.2 V
2	-13V2	F6	0 V	-14.2 V ... -12.4 V
	-7V		0 V	-7.35 V ... -6.65 V
	+7V		0 V	6.65 V ... 7.35 V
	+8V		0 V	7.6 V ... 8.4 V
	+3V3		0 V	+3.1 V ... +3.5 V
	+28V		0 V	+27 V ... + 29.9 V
	+3V0		0 V	+2.85 V ... 3.15 V
	+2V5		0 V	+2.4 V ... +2.6 V
	+1V2		0 V	1.14 V ... 1.26 V
	+0V9		0 V	0.85 V ... 0.95 V
1	+5V_STBY	F9	+4.5 V ... + 5.5 V Standby	+4.5 V ... + 5.5 V Standby
13			> +3 V	< 0.8 V
14...20			GND	GND

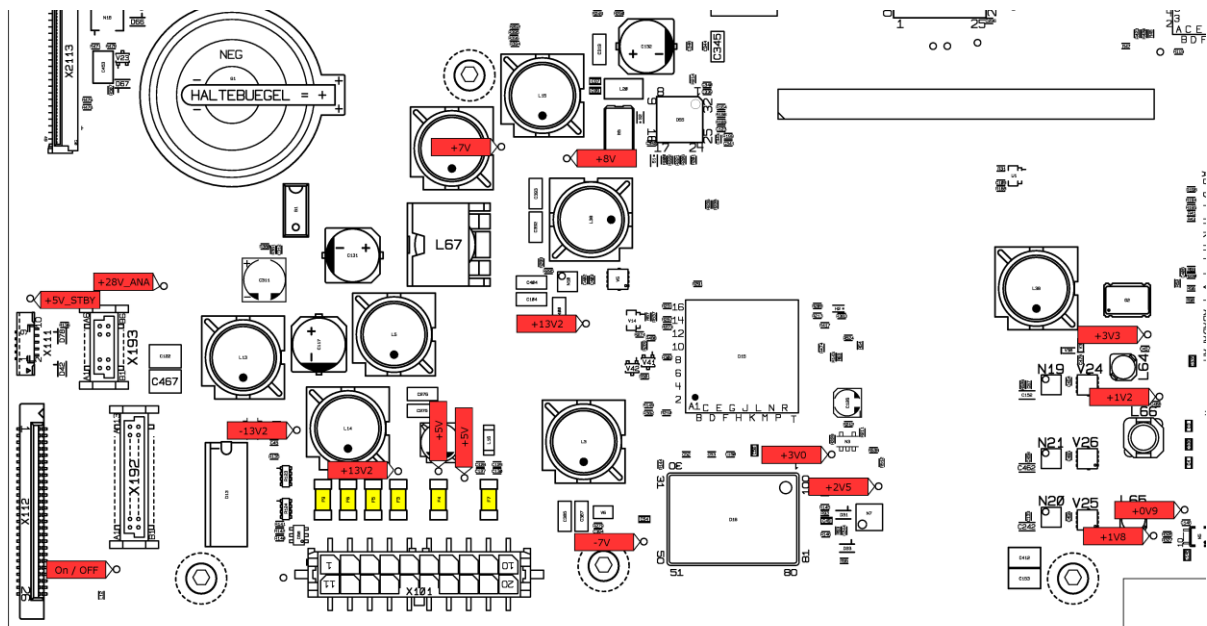

Fig. 3-7 Test Points and Power Supply Connector of the Basis Board

3.2.9.2 Fuses

Switch on the R&S SMB and measure the voltage drop across the fuses F3 – F7 (yellow marked see Fig. 3-3) with a multimeter. The voltage across every fuse should be in the range -100 mV ... +100 mV. The fuses might be blown due to a defective module other than the Basis Board. If one of the fuses is blown replace the fuse with the correct type given below. Remove all flat cable connections from the Basis Board (Flat cable to the RF Board, Step Attenuator and Reverse Power Protection to the front unit). Switch on the R&S SMB and check the voltage drop across the fuses after two minutes again. If one of the fuses is blown again the Basis Board is defective. If the fuses are OK switch off R&S SMB again and then connect the display and switch on the R&S SMB again. If one of the fuses is blown after two minutes and the display is not working the display is defective. If the RF Board is equipped with the Reference Oscillator B1 or B1H remove this unit first (see page 3.71). Now repeat the fuse test by first adding the connection to the RF Board and then adding the Reference Oscillator B1.

If the Step Attenuator module or Reverse Power Protection module is installed to the instrument, repeat the fuse test by connecting the modules one by one to the Basis Board. The module causing the blown fuse is defective.

Fuse	Type	R&S Part Number	Manufacturer Part Number
F3	T5A	1090.4442.00	Littlefuse R452.005 NRL (MRL)
F4	FF10A	6104.9199.00	Littlefuse R452.010 NRL (MRL)
F5	T5A	1090.4442.00	Littlefuse R452.005 NRL (MRL)
F6	T5A	1090.4442.00	Littlefuse R452.005 NRL (MRL)
F7	FF10A	6104.9199.00	Littlefuse R452.010 NRL (MRL)
F9	T5A	1090.4442.00	Littlefuse R452.005 NRL (MRL)

3.2.10 Troubleshooting – RF Board 13 Module

The tests listed below ensure that an assumed error on the RF Board module is not caused by a defective or incorrectly connected cable, incorrect adjustment or another module.

3.2.10.1 Internal Adjustment "Adjust All"

A comprehensive test of the module is to run the internal adjustment.

Normal action	Error, possible causes and corrective action
Internal adjustments call: SETUP - Internal Adjustments - Adjust All Internal adjustment of the RF Board is executed.	Abort during adjustment: The adjustments are all carried out exclusively on the RF Board, only the Diagnostic A/D converter on the Basis Board is needed. If the voltage levels at all Test Points on the Basis Board are in tolerance most probably the RF Board is defective. Check the RF Board being supplied correct (see page 3.34). If not in tolerance check the Basis Board (see page 3.32)

3.2.10.2 Supply Voltages

Remove the RF Board from the chassis and connect cable W222 from the Basis Board. Switch on the R&S SMB and measure the supply voltages of the RF Board at the series coils near its power supply connector (X222, see Fig. 3-4). The measured voltages have to meet the values given in the table below. If one or more voltages are not of the required level, check the Basis Board (see page 3.32).

Measuring Point	R&S SMB switched On
Shielding enclosure	GND
L6004	+3.1 V ... +3.5 V
L6001	+6.5 V ... +7.5 V
L6012	-7.5 V ... -6.5 V
L6010	+7.5 V ... +8.5 V
L6000	+12 V ... +14 V
L6002	-14 V ... -12 V
L6003	+26 V ... +30 V

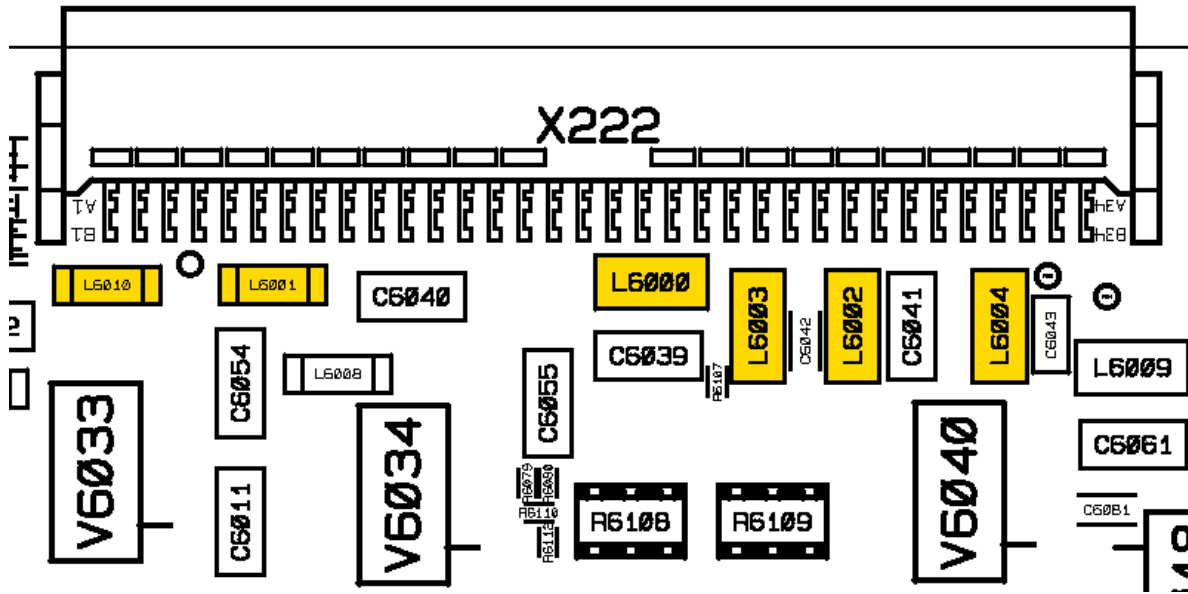

Fig. 3-8 Power Supply and digital interface connector of the RF Board.

3.2.10.3 Control Signals

The control signals of the RF Board can be measured at test points near connector X222 (see Fig. 3-9). Signals going to the RF Board are colored red and signals coming from the RF Board are colored blue.

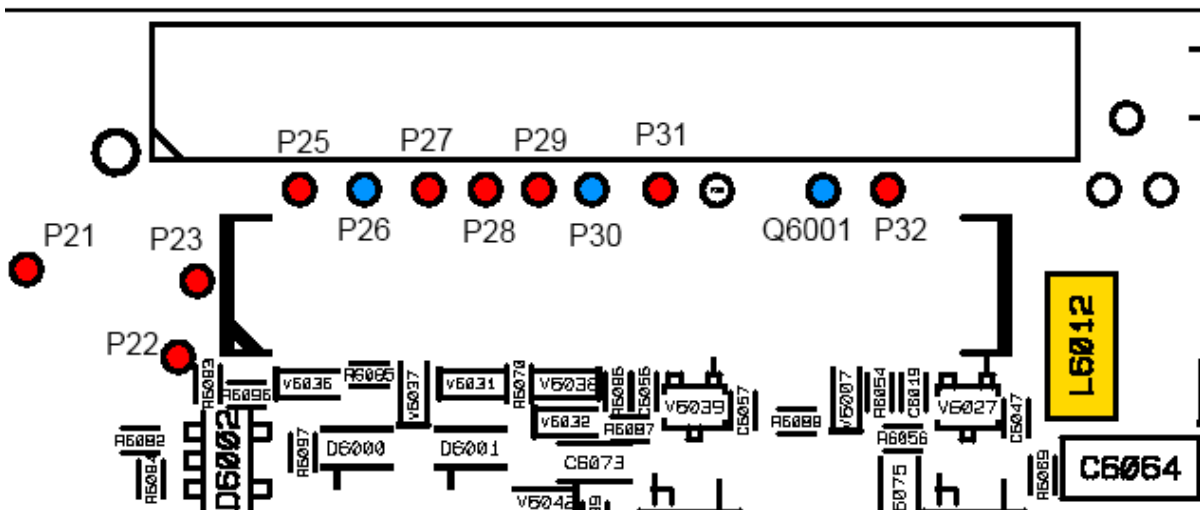

Fig. 3-9 Signal Test Points of the RF Board.

Perform the following settings at the R&S SMB:

- Preset
- RF on
- Unlock Protection Level 2: 147946
- **SETUP** - Test Point ⇒ Select Test Point ⇒ DIAG_SMB_RF_LCON
- **SETUP** - Test Point ⇒ State ⇒ on

Preset the R&S SMB and control the following signals with an Oscilloscope.

Oscilloscope settings:

- Voltage: 1 V / Div
- Timespan: 1 µs/ Div
- Trigger: Normal

Measure these signals

Test point	Function	Signal at normal operation	Defective
P23, P25, P27, P28	Logic Control Signals	Check the serial number of the RF Board displayed in the GUI: SETUP - Hardware-Config - RF Board - More... If the number is correct these signals are OK. If not measure these Test-Points with an Oscilloscope: They should toggle between 0 V and 3.3 V	Basis Board
P26	Logic Control Signal		RF Board
P29, P31	Reset	3.3 V	Basis Board
P30	Interrupt Signal	normal Operation: 3.3 V Switch R&S SMB to Reference extern without applying 10 MHz Reference signal: 0 V	RF Board
P32	Blank Signal	normal Operation: 0 V during Frequency switching: + 3,3 V	Basis Board
Q6001	Diagnosis Voltage	Voltage toggles on every update of the diagnosis between 0 V and about 1/5 of the Diagnosis voltage reading in the Display	RF Board
P21, P22, P23	Logic Control Signals	Check the serial number of the MOD-FPGA displayed in the GUI: SETUP - Hardware-Config - MOD-FPGA - More If the number is not 0.0 these signals are OK. If not measure these Test-Points with an Oscilloscope: They toggle between 0 V and 3.3 V during the first seconds after switching on the instrument	Basis Board
P26	Logic Control Signal		RF Board

If one of these Signals is not as described change the connector cable and test again. If the signals still do not match their description change the defective board according to the table.

3.2.10.4 Input and Output Signals

Connector, system	Signal name	Setting on signal generator	Frequency	Level	Signal flow
X212, SMA	RF13	RF on	100 kHz to 12.75 GHz	-20 dBm to +30 dBm	to RF connector at front
X216 SMA	LO13		6.375 to 12.75 GHz	10 to +18 dBm	LO output to RF Board 20
X215, SMP	LFGEN	LF out on	0.01 Hz to 1 MHz	0 V to 3 V	to LF out at front
X214, SMP	MODEXT	AM/FM/PM Source Ext	0.0 to 1 MHz	-1 V to +1 V	From Mod ext at front
X213, SMP	REF200		200 MHz	4±2 dBm	Output for testing purposes
X217, SMP	VDET20		0.0 to 1 MHz	0 to +8 V	Input of detector voltage from RF Board 20
X218, SMP	LCON20		0.0 to 1 MHz	0 to +7 V	Loop control voltage to RF Board 20

3.2.10.5 Error Messages Concerning the RF Board Module

Error message	Error correction
"ALC unlocked"	<ul style="list-style-type: none"> ➤ Automatic Level Control ALC exceeds upper bound. ➤ Set attenuator mode "Auto". ➤ Set level to specified value. ➤ If error message does not disappear, check the diagnosis (see Troubleshooting with Internal Selftest). If the diagnosis measurements work change the RF Board.
"Synthesis main-loop PLL unlocked"	<ul style="list-style-type: none"> ➤ Execute Internal Adjustment "Adjust Synthesis". ➤ If the error message does not disappear change the module.
"Synthesis adjustment failed"	<ul style="list-style-type: none"> ➤ Execute Internal Adjustment "Adjust Synthesis". ➤ If error message does not disappear, check the diagnosis (see Troubleshooting with Internal Selftest). If the diagnosis measurements work change the RF Board.
"Synthesis adjustment data invalid"	<ul style="list-style-type: none"> ➤ Execute Internal Adjustment "Adjust Synthesis". ➤ If the error message does not disappear, check the diagnosis (see Troubleshooting with Internal Selftest). If the diagnosis measurements work change the RF Board.

3.2.10.6 Warnings Concerning the RF Board Module

Warnings	Warning correction
"External reference oscillator out of range or disconnected"	<ul style="list-style-type: none"> ➤ Check the external reference input signal. ➤ If the input signal is correct and the error message is still displayed, change the module.
"Pep value greater than defined limit"	<ul style="list-style-type: none"> ➤ The peak envelope power (PEP) is higher than the set upper limit. ➤ Reduce the output level.
"Pep value less than defined lower bound (fix range)"	<ul style="list-style-type: none"> ➤ The peak envelope power (PEP) is lower than the permissible lower limit in the "fix range" mode of the attenuator. ➤ Increase the output level, set the attenuator mode to "Auto", or reset the "fix range" by briefly switching the attenuator mode to "Auto" and then switching back to "Fixed".
"Pep value greater than defined upper bound (fix range)"	<ul style="list-style-type: none"> ➤ The peak envelope power (PEP) is higher than the permissible upper limit in the "fix range" mode of the attenuator. ➤ Reduce the output level, set the attenuator mode to "Auto", or reset the "fix range" by briefly switching the attenuator mode to "Auto" and then switching back to "Fixed".
"Settings conflict, pep value vs. AM depth"	<ul style="list-style-type: none"> ➤ The peak envelope power (PEP) is higher than the permissible upper limit because of the set AM modulation depth. ➤ Reduce the output level or increase the level limit (e.g. by switching the attenuator mode to "Auto" if "Normal" or "Fixed" mode was set). Reducing the AM modulation depth will also eliminate the warning.
"Settings conflict, pep value greater than allowed level vs. frequency"	<ul style="list-style-type: none"> ➤ The full output level range cannot be utilized at low frequencies below 1 MHz. because internal components may be overloaded. Please check specified level range in the datasheet for the given frequency option.
"Settings-conflict: PulseGen"	<ul style="list-style-type: none"> ➤ Settings for the internal pulse generator are incorrect. Check timing settings of the pulse generator.
"Maximum temperature exceeded"	<ul style="list-style-type: none"> ➤ The internal temperature of the RF Board is too high. ➤ If the ambient temperature is within specified limits, the fan unit may be defective.

3.2.10.7 Frequency Error

Error	Error correction
Internal reference frequency: Frequency error greater than limit given in datasheet	<p data-bbox="654 418 1410 600">➤ The frequency accuracy of the synthesizer is determined (set to internal reference) by a highly stable 200 MHz quartz oscillator that is set to a calibrated frequency standard at the R&S factory. This oscillator is subject to ageing and hence its output frequency can be adjusted (see chapter 2 “Internal Counter Reference Oscillator Adjustment”).</p> <p data-bbox="692 618 766 647">Note:</p> <p data-bbox="692 672 1382 871">The internal reference can be impaired under the menu Setup - Reference Oscillator - Adjustment. This setting does not affect the factory adjustment and can be reset at any time by means of deactivation. If the tuning range is insufficient to reach the frequency error given in the datasheet the TCXO is defective. Replace the RF Board.</p>

3.2.11 Troubleshooting – Reference Oscillator Module

If the frequency Error of the R&S SMB is $> 3 \cdot 10^{-6}$ the Reference Oscillator is defective, change the module.

3.2.11.1 Input and Output Signals

The Reference Oscillator has only one Futurebus connector (X1). The Reference Oscillator is plugged into the RF Board (X221 see Fig. 3-10). All signals and the supply voltage are fed to the module through this connector. Check the voltages for the OCXO being according to the following table. To test the serial bus signals watch the signal lines while toggling between internal and external reference with an Oscilloscope. Voltage Levels are 0 V and 3.3 V.

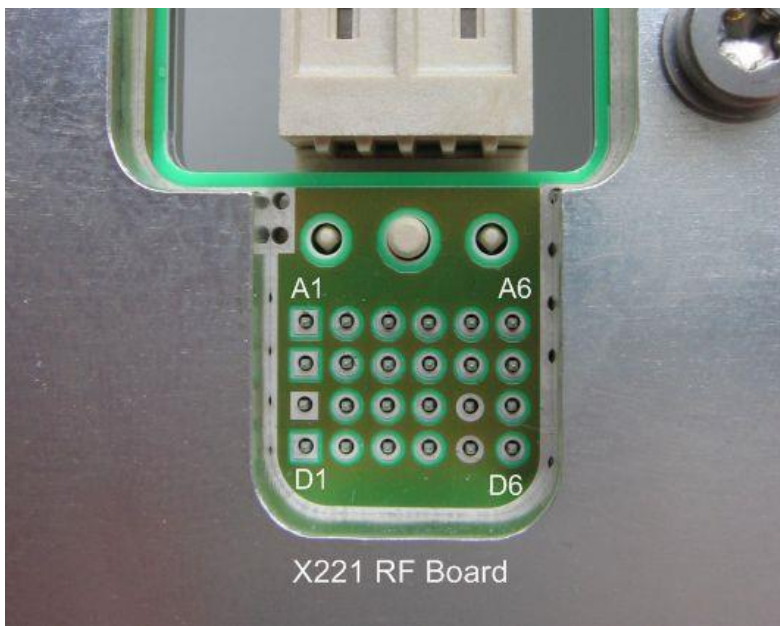

Fig. 3-10 Pin location X221 on RF Board

Pin of X221 RF Board	Voltage/Signal	Pin of X221 RF Board	Voltage/Signal	Pin of X221 RF Board	Voltage/Signal	Pin of X221 RF Board	Voltage/Signal
A1	Clock-signal serial bus	B1	NC	C1	GND	D1	+4.8 V - +5.6 V
A2	Data-signal to option serial bus	B2	0 V when Oven Cold	C2	NC	D2	GND
A3	Chip Select signal serial bus	B3	Data signal from option to serial bus	C3	+5.0 V on internal ref. 0 V on external ref.	D3	10 MHz LVDS reference signal
A4	10 MHz reference signal	B4	GND	C4	NC	D4	
A5	High Z	B5	+3.3 V	C5	GND	D5	GND
A6	+4.8 V - +5.6 V	B6	+4.8 V - +5.6 V	C6	+11 V – +14 V	D6	-8 V – -12 V

3.2.11.2 Error Messages Concerning the Reference Oscillator Module

Error message	Error correction
<ul style="list-style-type: none"> ➤ "OCXO 10 MHz oven cold" 	<ul style="list-style-type: none"> ➤ If this message does not disappear after 10 minutes, OCXO is defective, change the module.
<ul style="list-style-type: none"> ➤ "Synchronization error on internal reference" ➤ 	<ul style="list-style-type: none"> ➤ Switch the R&S SMB to external Reference and supply a 10 MHz 10 dBm signal to the Reference Input of the RF BOARD. If the error disappears and the R&S SMB is working correct the OCXO is defective, change the module.
<ul style="list-style-type: none"> ➤ "OCXO: cannot read EEPROM data" ➤ "OCXO: cannot store adjustment data" 	<ul style="list-style-type: none"> ➤ This indicates problems concerning the data transfer from and to the EEPROM of the module. If changing the module does not help, change the RF Board module.

3.2.11.3 Frequency Error, Reference Oscillator Adjustment

Error	Error correction
<ul style="list-style-type: none"> ➤ Internal reference frequency: ➤ Frequency error greater than limit given in datasheet 	<ul style="list-style-type: none"> ➤ The frequency accuracy of the synthesizer is determined (set to internal reference) by a highly stable oven controlled 10 MHz quartz oscillator that is set to a calibrated frequency standard at the R&S factory. This oscillator is subject to ageing and hence its output frequency can be adjusted (see chapter 2 "Internal Counter Reference Oscillator Adjustment"). <p>Note:</p> <p>The internal reference can be tuned by up to approx. $\pm 10^{-6}$ under the menu Setup - Reference Oscillator - Adjustment. This setting does not affect the factory adjustment and can be reset at any time by means of deactivation.</p>

3.2.12 Troubleshooting – Active Step Attenuator Module

3.2.12.1 Supply Voltages

Remove the Step Attenuator from the chassis and connect cable W195 (or W983 if Reverse Power Protection is installed) from the Basis Board. Switch on the R&S SMB and measure the supply voltages of the Step Attenuator at the capacitors near its power supply connector (X700, see Fig. 3-11). The measured voltages have to meet the values given in the table below. If one or more voltages are not of the required level, check the Basis Board (see page 3.32).

Measuring Point	R&S SMB switched On
Shielding enclosure	GND
C600	+7.5 V ... +8.5 V
C605	+12 V ... +14 V
Z701	-14 V ... -12 V

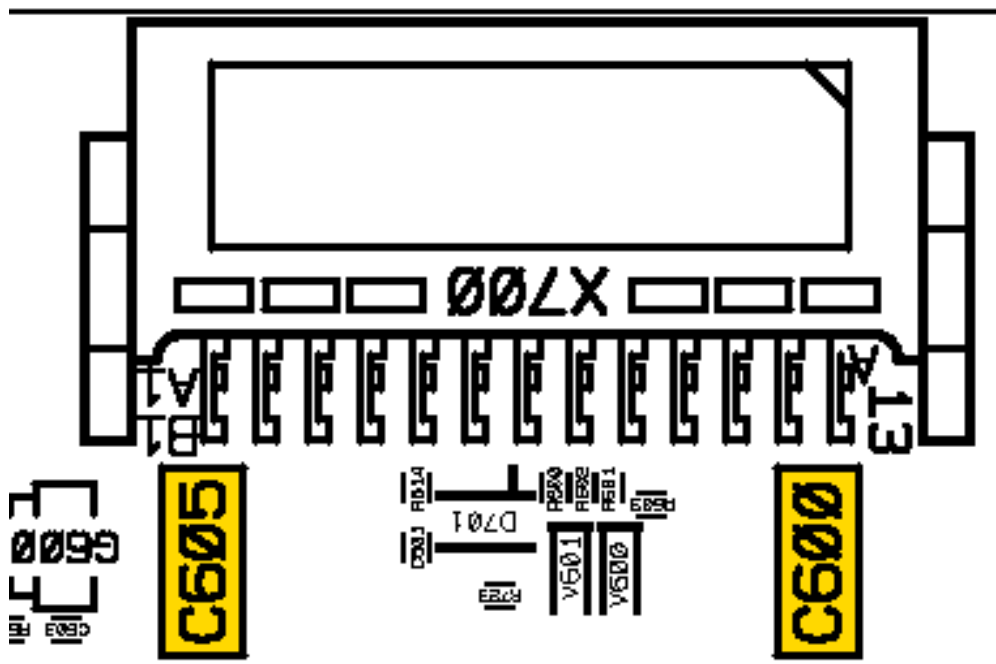

Fig. 3-11 Power Supply Connector of Active Step Attenuator (top view)

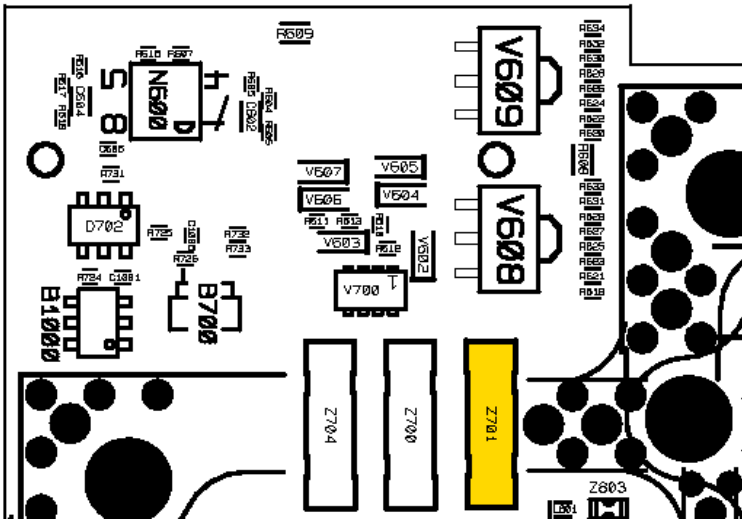

Fig. 3-12 Power Supply Connector of Active Step Attenuator (bottom view)

If the supply voltages do not comply with the given values in the above table, change the connector cable and test again. If the supply voltages still do not comply, change the module.

3.2.13 Troubleshooting – Reverse Power Protection Module

3.2.13.1 Supply Voltages

Remove the Reverse Power Protection from the chassis and connect cable W983 from the Basis Board. Switch on the R&S SMB and measure the supply voltages of the Reverse Power Protection at the components near its power supply connector (X700, see Fig. 3-13). The measured voltages have to meet the values given in the table below. If one or more voltages are not of the required level, check the Basis Board (see page 3.32).

Measuring Point	R&S SMB switched On
Shielding enclosure	GND
N3.1	+7.5 ... +8.5 V
N1.1, N1.3	+12 V ... +14 V
N2.2	-14 V ... -12 V

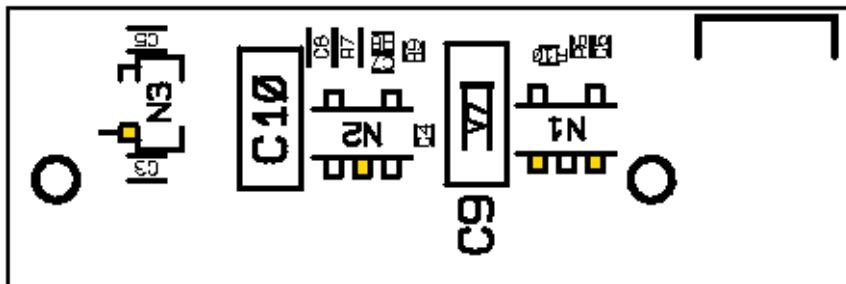

Fig. 3-13 Power Supply Connector of Reverse Power Protection (bottom view)

If the supply voltages do not comply with the given values in the above table, change the connector cable and test again. If the supply voltages still do not comply, change the module.

3.2.13.2 Warnings Concerning the Reverse Power Protection Module

<p>“Output protection tripped”</p>	<ul style="list-style-type: none"> ➤ Excessive reverse RF power or dc voltage at the RF port tripped the output protection. ➤ Remove the overload condition and press the “RF ON/OFF” button to enter normal operation.
------------------------------------	---

3.2.14 Troubleshooting – RFBOARD20 Module

The tests listed below ensure that an assumed error on the module is not caused by a defective or incorrectly connected cable, incorrect adjustment or another module.

3.2.14.1 Wiring and cables

First, checking the wiring and the cables in the instrument help to locate the failure. The wiring of all semi-rigid RF cables, flexible coaxial cables and flat ribbon cables should be verified; compare block diagram of the instrument. A damaged cable or the mating of any connector can cause the instrument not to work properly; plug and socket at the connection should be considered. The torque at each screw-in RF connector needs to be inspected.

Special attention should be kept on the wiring of the flexible coaxial cables of the automatic level control circuitry at X218 LCON20, X217 VDET20, X220 VDET20HP and X219VDET40.

3.2.14.2 Checking input and output signals

Second, input and output signals of the module should be tested prior to the replacement of the module.

- **Supply voltages**

Measuring the supply voltages of a module can be done with a DC voltmeter or more conveniently by using the modules “Test Point”. The diagnose voltages can be measured after the following settings:

- Unlock Protection Level 2: 147946
- **[SETUP]** - Test Point ⇒ **Select Test Point** ⇒ **DIAG_SMB_x_y**
- **[SETUP]** - Test Point ⇒ **State** ⇒ **on**

Supply voltages are measured and checked during the internal selftest.

- **Digital control signals**

The communication with the module can be checked by reading the “Hardware Config” in the setup menu; installed modules with serial number.

- **Analog control signals**

Interrupting the loop by disconnecting W217 at X217 VDET20 is recommended for measuring the ALC signals; LCON20 must not be interrupted. The ALC voltages can be measured with a DC Voltmeter using a SMP-T-adapter at the corresponding connector; some signals can be measured via “Test Point”.

<i>Connector, cable</i>	<i>Signal name</i>	<i>Setting on signal generator</i>	<i>Value / Test Point</i>	<i>Signal flow</i>
RFB 13 X218, W218	LCON20	P_max, 12.75 GHz < f_set	> 6.5 V RFB120_LCON_20G	RFB13 → RFB20
RFB20 X217	VDET20	P_max, 12.75 GHz < f_set	> 2.0 V	RFB20 → RFB13
HP20 X220, W220 *	VDET20HP	P_max, 1 GHz < f_set ≤ 20 GHz	> 2.0 V HP20_DET	HP20 → RFB20
FD40 / FD40P X217, W219 *	VDET40	P_max, 20 GHz < f_set ≤ 40 GHz	> 2.0 V FD40_VDET40	FD40 / FD40P → RFB20

* only if module FD40 or FD40P installed

• **RF signals**

The RF signals at the input and output of the module are listed in the table below. The signals can be measured at the connector when the instrument is set accordingly.

<i>Connector, cable</i>	<i>Signal name</i>	<i>Setting on signal generator</i>	<i>Value</i>	<i>Signal flow</i>
RFB13 X216, W212_2	LO13	P_max, 12.75 GHz < f_set ≤ 20 GHz P_max, 20 GHz < f_set ≤ 25.5 GHz *	> 10 dBm @ f_set / 2 > 10 dBm @ f_set / 2	RFB13 → RFB20
RFB13 X212, W220	RF13	P_max, 1 GHz < f_set ≤ 12.75 GHz	> 16 dBm	RFB13 → RFB20
RFB20 X212	RF20	P_max, 1 GHz < f_set ≤ 20 GHz	> 15 dBm	RFB20 → RF front / HP20 / FD40 / FD40P / ATT40
RFB20 X215	LO20	P_max, 20 GHz < f_set ≤ 40 GHz *	> 12 dBm @ f_set / 2	RFB20 → FD40 / FD40P

* only if module FD40 or FD40P installed

3.2.15 Troubleshooting – HP20 / FILTER20 Module

The tests listed below ensure that an assumed error on the module is not caused by a defective or incorrectly connected cable, incorrect adjustment or another module.

3.2.15.1 Wiring and cables

First, checking the wiring and the cables in the instrument help to locate the failure. The wiring of all semi-rigid RF cables, flexible coaxial cables and flat ribbon cables should be verified; compare block diagram of the instrument. A damaged cable or the mating of any connector can cause the instrument not to work properly; plug and socket at the connection should be considered. The torque at each screw-in RF connector needs to be inspected.

Special attention should be kept on the wiring of the flexible coaxial cable of the automatic level control circuitry at X973 VDET20HP.

3.2.15.2 Checking input and output signals

Second, input and output signals of the module should be tested prior to the replacement of the module.

- **Supply voltages**

Measuring the supply voltages of a module can be done with a DC voltmeter or more conveniently by using the modules “Test Point”. The diagnose voltages can be measured after the following settings:

- Unlock Protection Level 2: 147946
- **SETUP** - Test Point ⇒ Select Test Point ⇒ DIAG_SMB_x_y
- **SETUP** - Test Point ⇒ State ⇒ on

Supply voltages are measured and checked during the internal selftest.

- **Digital control signals**

The communication with the module can be checked by reading the “Hardware Config” in the setup menu; installed modules with serial number.

- **Analog control signals**

Interrupting the loop by disconnecting W217 at X217 VDET20 is recommended for measuring the ALC signals; LCON20 must not be interrupted. The ALC voltages can be measured with a DC Voltmeter using a SMP-T-adapter at the corresponding connector; some signals can be measured via “Test Point”.

Connector, cable	Signal name	Setting on signal generator	Value / Test Point	Signal flow
HP20 X220, W220	VDET20HP	P_max, 1 GHz < f_set ≤ 20 GHz	> 2.0 V HP20_DET	HP20 → RFB20

- **RF signals**

The RF signals at the input and output of the module are listed in the table below. The signals can be measured at the connector when the instrument is set accordingly.

Connector, cable	Signal name	Setting on signal generator	Value	Signal flow
RFB20 X212, W921	RF20_IN	P_max, 1 GHz < f_set ≤ 20 GHz	> 15 dBm	RFB20 → HP20
HP20 X972	RF_OUT	P_max, 1 GHz < f_set ≤ 20 GHz	> 20 dBm	HP20 → RF front / FD40P / ATT40

3.2.16 Troubleshooting – FD40 / FD40P Module

The tests listed below ensure that an assumed error on the module is not caused by a defective or incorrectly connected cable, incorrect adjustment or another module.

3.2.16.1 Wiring and cables

First, checking the wiring and the cables in the instrument help to locate the failure. The wiring of all semi-rigid RF cables, flexible coaxial cables and flat ribbon cables should be verified; compare block diagram of the instrument. A damaged cable or the mating of any connector can cause the instrument not to work properly; plug and socket at the connection should be considered. The torque at each screw-in RF connector needs to be inspected.

Special attention should be kept on the wiring of the flexible coaxial cable of the automatic level control circuitry at X217 VDET40

3.2.16.2 Checking input and output signals

Second, input and output signals of the module should be tested prior to the replacement of the module.

- **Supply voltages**

Measuring the supply voltages of a module can be done with a DC voltmeter or more conveniently by using the modules “Test Point”. The diagnose voltages can be measured after the following settings:

- Unlock Protection Level 2: 147946
- **SETUP** - Test Point ⇒ Select Test Point ⇒ DIAG_SMB_x_y
- **SETUP** - Test Point ⇒ State ⇒ on

Supply voltages are measured and checked during the internal selftest.

- **Digital control signals**

The communication with the module can be checked by reading the “Hardware Config” in the setup menu; installed modules with serial number.

- **Analog control signals**

Interrupting the loop by disconnecting W217 at X217 VDET20 is recommended for measuring the ALC signals; LCON20 must not be interrupted. The ALC voltages can be measured with a DC Voltmeter using a SMP-T-adapter at the corresponding connector; some signals can be measured via “Test Point”.

Connector, cable	Signal name	Setting on signal generator	Value / Test Point	Signal flow
FD40 / FD40P X217, W219	VDET40	P_max, 20 GHz < f_set ≤ 40 GHz	> 2.0 V FD40_VDET40	FD40 / FD40P → RFB20

- **RF signals**

The RF signals at the input and output of the module are listed in the table below. The signals can be measured at the connector when the instrument is set accordingly.

<i>Connector, cable</i>	<i>Signal name</i>	<i>Setting on signal generator</i>	<i>Value</i>	<i>Signal flow</i>
RFB20 X215, W215	LO20	P_max, 20 GHz < f_set ≤ 40 GHz	> 12 dBm @ f_set / 2	RFB20 → FD40 / FD40P
<i>without option B32</i> RFB20 X212, W921	RF20	P_max, 1 GHz < f_set ≤ 20 GHz	> 15 dBm	RFB20 → FD40
<i>without option B32</i> FD40 X212	RF40	P_max, 1 GHz < f_set ≤ 40 GHz	> 10 dBm	FD40 → RF front / ATT40
<i>with option</i> B26 / B32 HP20 X972, W993	RF_OUT	P_max, 1 GHz < f_set ≤ 20 GHz	> 20 dBm	Filter20 / HP20 → FD40P
<i>with option B32</i> FD40P X212	RF40	P_max, 1 GHz < f_set ≤ 40 GHz	> 15 dBm	FD40P → RF front / ATT40

3.2.17 Troubleshooting – ATT40 Module

The tests listed below ensure that an assumed error on the module is not caused by a defective or incorrectly connected cable, incorrect adjustment or another module.

3.2.17.1 Wiring and cables

First, checking the wiring and the cables in the instrument help to locate the failure. The wiring of all semi-rigid RF and flat ribbon cables should be verified; compare block diagram of the instrument. A damaged cable or the mating of any connector can cause the instrument not to work properly; plug and socket at the connection should be considered. The torque at each screw-in RF connector needs to be inspected.

3.2.17.2 Checking input and output signals

Second, input and output signals of the module should be tested prior to the replacement of the module.

- **Supply voltages**

Measuring the supply voltages of a module can be done with a DC voltmeter or more conveniently by using the modules “Test Point”. The diagnose voltages can be measured after the following settings:

- Unlock Protection Level 2: 147946
- **SETUP** - Test Point ⇒ Select Test Point ⇒ DIAG_SMB_x_y
- **SETUP** - Test Point ⇒ State ⇒ on

Supply voltages are measured and checked during the internal selftest.

- **Digital control signals**

The communication with the module can be checked by reading the “Hardware Config” in the setup menu; installed modules with serial number.

- **RF signals**

The RF signals at the input and output of the module are listed in the table below. The signals can be measured at the connector when the instrument is set accordingly.

Connector, cable	Signal name	Setting on signal generator	Value	Signal flow
RFB20 X212, HP20 X972 Filter20 X972 FD40 X212 FD40P X212	RF20 RF_OUT RF_OUT RF40 RF40	P_max, 1 GHz < f_set ≤ 40 GHz	P_IN_ATT40	RFB20 / HP20 / Filter20 / FD40 / FD40P → ATT40
ATT40 X2	RF_OUT	P_max, 1 GHz < f_set ≤ 40 GHz	P_OUT_ATT40 P_IN_ATT40 – P_OUT_ATT40 < 5 dB	ATT40 → RF front

3.3 Module Replacement

This section describes in detail the replacement of modules. Chapter 5 provides information on how to order spare parts; it contains the list of mechanical parts with order numbers and the illustrations for module replacement.

NOTICE

Protection of mechanical components

Please adhere to the starting torques given below:

For screws			
Thread size M	2.5	3	4
Torque in Nm	0.66	1.03	2.35
For connectors			
Type	K / PC2.9	PC2.4	PC3.5
Torque in Ncm	100	90	100
Tolerance	-0/+20 %	± 10 Ncm	-0/+20 %

Protection of electronic components

Always wear gloves when touching the electronic components.

3.3.1 Overview of the Modules

Table 3-1 Overview - module replacement

Module	Designation	Replacement Part Order No.	See page
Power Supply (AC 90 V to 264 V)	A50	1406.7336.00 or 1406.7020.00 (only for instruments with option SMB-B26)	3.69
Basis Board 3	A100	1406.6800.06	3.62
RF Board 13 GHz	A200	1406.7307.02 or 1406.7371.02	3.67
Reference Oscillator OCXO R&S SMB-B1	A210	1407.3105.02	3.71
Reference Oscillator OCXO R&S SMB-B1H	A210	1407.3105.03	3.71
Active Step Attenuator ASATT13 only with option R&S SMB-B112	A950	1412.5360.02	3.72
Reverse Power Protection RPP13 only with option R&S SMB-B30	A980	1412.6244.02	3.73
Front Unit R&S SMB	A300	1406.7820.02	3.55
Encoder Board	A310	1300.3044.02	3.59
3.5" TFT (QVGA DRGB LCD)	A330	3586.0172.00	3.58
Push Button Board Set or Flex. Switch Board (mod. 03/04)	A320	1406.7542.00 1406.9180.00	3.60
Front Cover		1406.9068.00	3.55
Fan Units	E1, E2	1406.6330.00	3.70
Lithium battery CR 2477N (3.0 V / 0.95 AH)		4052.5673.00	3.64
RF Board 20 GHz only with option R&S SMB-B120/-B120L/-B131/-B140 R&S SMB-B140L/-B140N	A220	1406.7407.02	3.74
HighPower HP20 GHz only with option R&S SMB-B31/-B32	A970	1407.1260.02	3.75
Step Attenuator 20 GHz only with option R&S SMB-B120	A960	1170.0094.02	3.78
Step Attenuator 40 GHz only with option R&S SMB-B131/-B140/-B140N	A960	1170.0113.02	3.78
Doubler FD40 only with option R&S SMB-B140/-B140L only with option R&S SMB-B140N	A820	1312.1006.02 1312.1006.27	3.79
Doubler FD40P only with option R&S SMB-B32 only with option R&S SMB-B131	A990	1407.1360.02 1315.0500.31	3.80



All modules should be replaced with modules with the same part number.
The words "left" and "right" in the manual always refer to the front view of the instrument.

3.3.2 After replacing an assembly

After you have replaced one of the assemblies, certain adjustments, functional checks or performance tests have to be carried out. Please refer to chapter 2 “Procedures after module replacement”.

3.3.3 Dismounting the Case

- Remove the test port adapter from the instrument front.
- Put the instrument on the front shock mounts.
- Unscrew the four screws (1096.4896.00) of the rear shock mounts (rear right 1096.6647.00 and rear left 1096.6630.00) on both sides and take them off.
- Pull off the case (1406.9151.00).

3.3.4 Mounting the Case

- Remove the test port adapter.
- Put the instrument on the front shock mounts.
- Pull down the case (1406.9151.00).
- Mount the rear shock mounts (rear right 1096.6647.00 and rear left 1096.6630.00) on both sides with the four screws (1096.4896.00).



NOTICE**Risk of damage to the instrument**

Ensure that the power supply cord is disconnected.

Remove the test port adapter first, after put the instrument on the front shock mounts.

3.3.5 Replacing Fuses

NOTICE**Risk of damage to the instrument**

Ensure that the power supply cord is disconnected.

If you are not using the supplied spares, be sure to use fuses of the same type and rating.

- Switch off the instrument.
- Disconnect the power supply cord.
- To replace a fuse, unscrew the fuse holder at the rear panel of the instrument.



3.3.6 Replacing the Front Cover and the Front Unit (A300)

3.3.6.1 Removing the Front Cover

- Switch off the instrument and pull the mains plug.
- Dismounting the case (see page 3.53).
- Remove the front shock mounts left (1096.6618.00) and right (1096.6624.00).
- Pull off the front cover (1406.7520.00) towards the front.



3.3.6.2 Removing the Front Unit

- Pull off the DV cables W214 MOD EXT (1406.9697.00) and W215 LF (1406.9700.00).

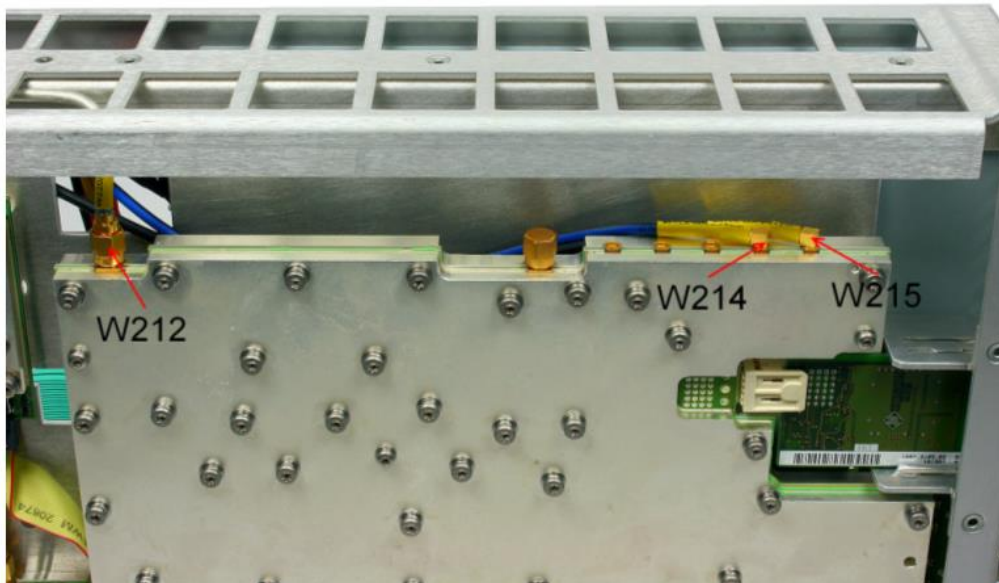

- Disconnect the flex. cables W310 from X111, Display cable from X2113 and the flex. switchboard cable from X112.

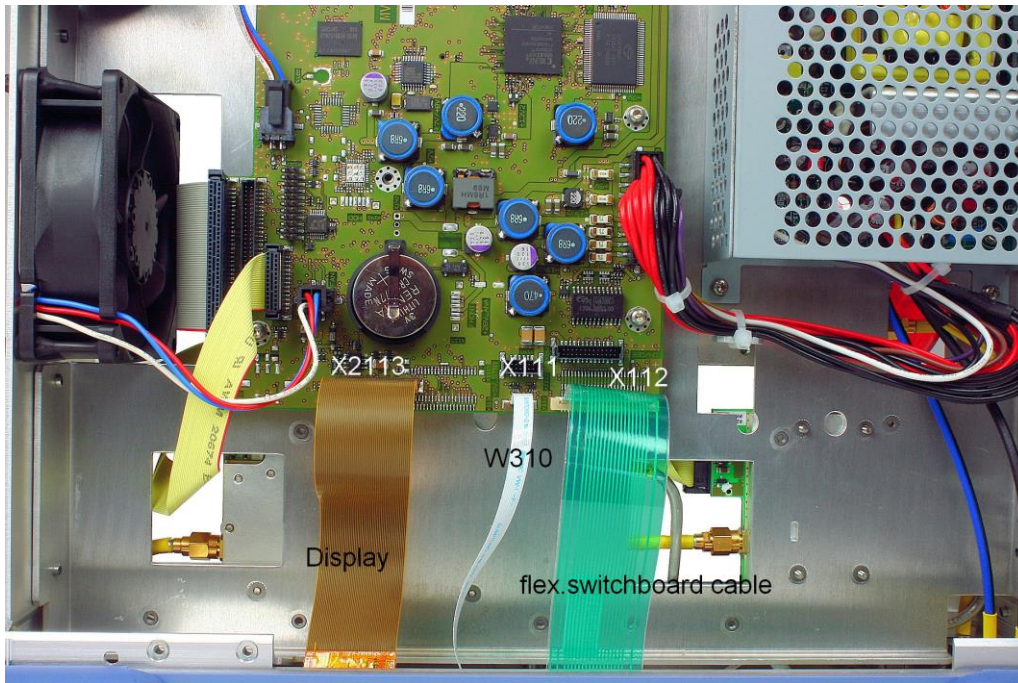

- Unscrew eight countersunk screws (1148.2752.00) in the front frame, two at the top, two at the bottom and four on the front.



- Completely remove the front unit with keyboard and TFT display towards the front (front unit 1406.7820.03).
- To remove the RF cable W212 (1406.9322.00), unscrew the nut and pull off the RF cable W212 backwards.

NOTICE

With option ASATT 13 GHz (A950) installed remove the cable W221 (1406.9274.00).
With option R&S SMB-B30 "Reverse Power Protection" installed remove the cable W982 (1406.9480.00).

- To remove the RF cables W214 or W215 unscrew the nut and pull of the RF cable forwards.

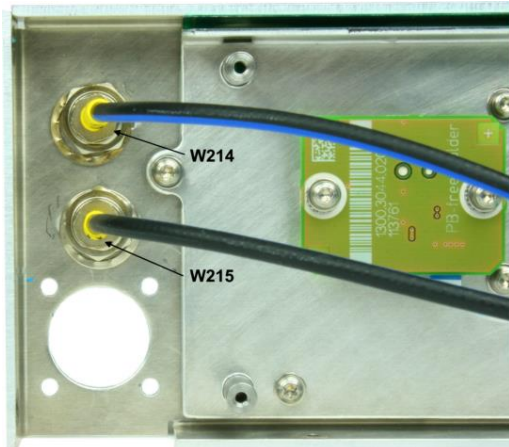

- Remove the two nuts and pull out the RF cables W214 and W215 forwards.
- To remove the front adapter 1021.0493.00 unscrew the holder 1406.9168.00 with the two screws 1148.3288.00 and unscrew the nut.

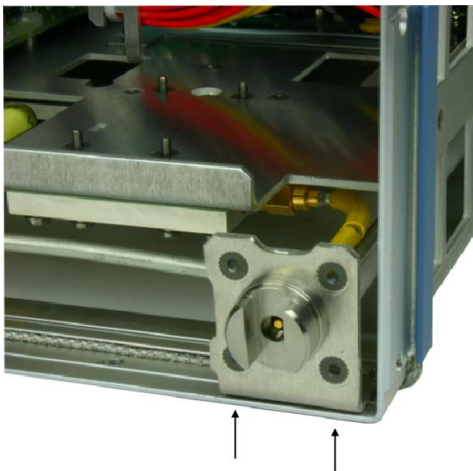
**NOTICE**

Store the RF cables at a safe place.
These cables are not components of the front unit.

When you mount the cables, ensure their correct position in the front unit.

3.3.6.3 Mounting the Front Unit

- Place the front unit and fix it with eight countersunk screws (1148.2752.00).
- Reconnect the cables to the RF-board (W214 and W215) and to the basis board (W310, display cable and the flex. switchboard cable). Make sure that cable W310 is reconnected as described.



3.3.6.4 Mounting the Front Cover

- Mount the new front cover.
- Place the shock mounts (right 1096.6624.00, left 1096.6618.00) and fix them with four screws (1096.4896.00).

3.3.6.5 Replacing the TFT Display (A330), Encoder Board (A310), Flex. Switch Board and Pushbutton Board Set

It is recommended to replace the front unit as a whole. Principally, it is possible to replace the individual components of the front unit (see figure below).

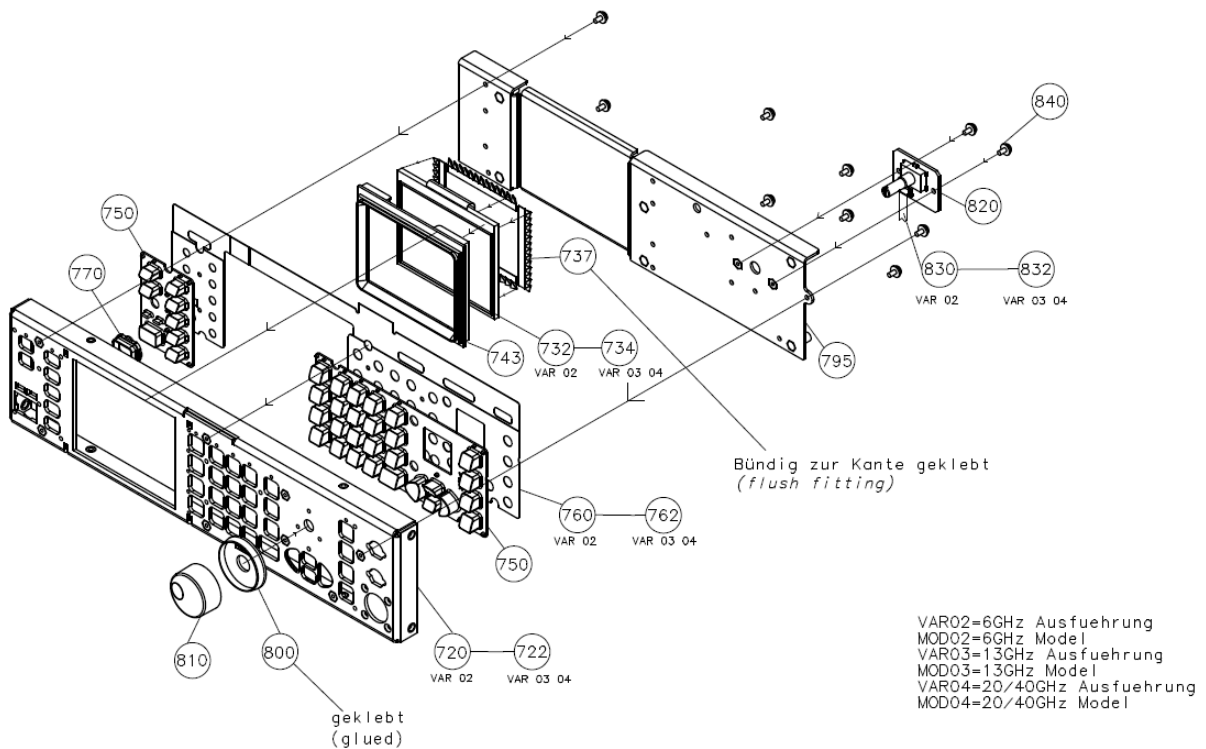

- Switch off the instrument and pull the mains plug.
- Unscrew the four screws of the shock mounts (right 1096.6624.00, left 1096.6618.00) on both sides and take them off.
- Dismounting the case (see page 3.53).
- Remove the front cover and the front unit (see above).
- Place the front unit together with the keys onto a clean surface.

3.3.6.6 Replacing the Encoder Board

- Remove the knob (0852.1086.00) from the front.

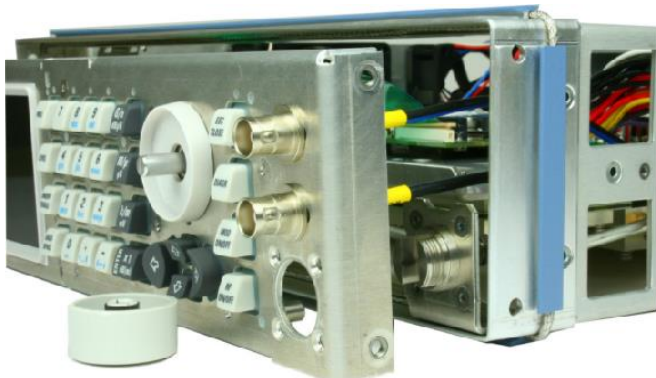

- Unscrew two combination screws (1148.3059.00).

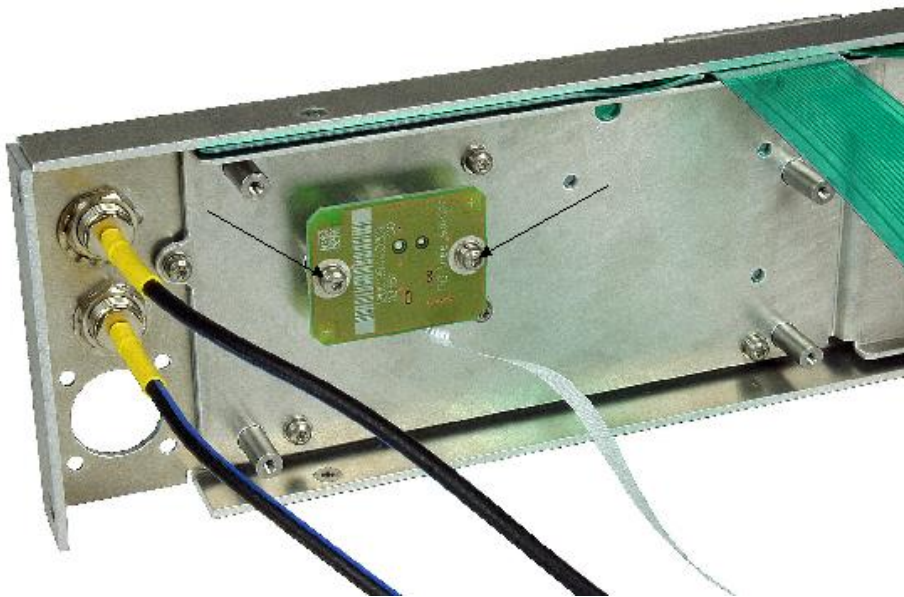

- Replace the encoder board (1300.3044.02) and fix it with two combination screws (1148.3059.00).

3.3.6.7 Replacing the TFT Display, Flex. Switch Board and Pushbutton Board Set

- Remove the encoder board A310 (see above).
- Unscrew the eight combination screws (1148.3059.00) and remove the holding plate (1406.7759.00).

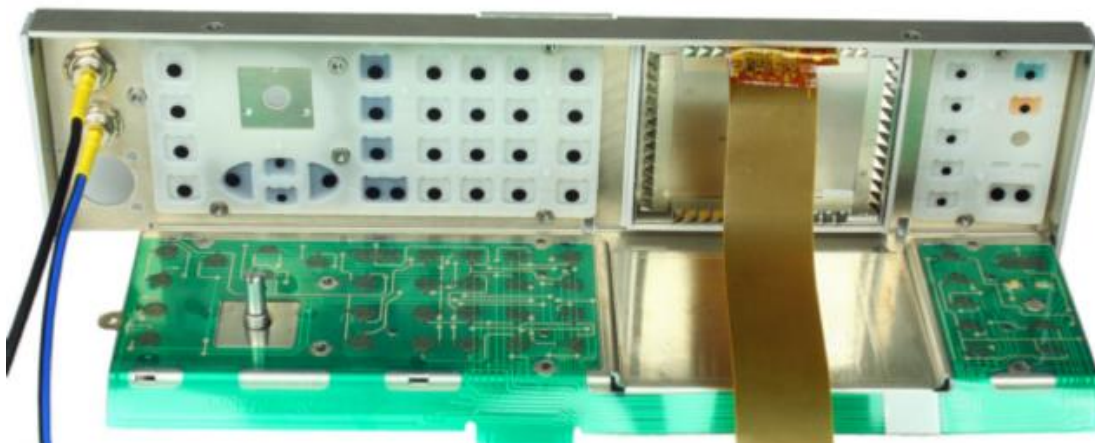
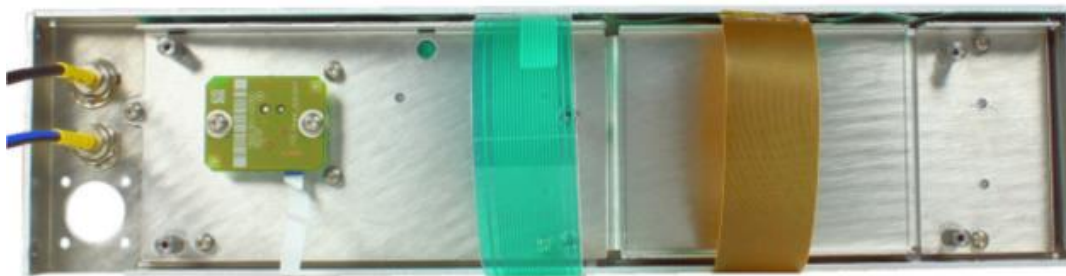

- The pushbutton board set (1406.7542.00), the flex. Switch board A320 (1406.9180.00 mod. 03/04) and the TFT 3.5" display (3586.0172.00 mod. 03/04) can now be replaced.
-

NOTICE**Risk of damage to the board**

When installing the items, make sure they are free of dust.

- Fit the holding plate (2406.7759.00) and fix it with eight combination screws (1148.3059.00).
- Fit the encoder board (W310) with two combination screws (1148.3059.00).
- Move the front cover and the front unit (see above).
- Mount the tube.

3.3.7 Replacing the Basis Board 3 (A100)

3.3.7.1 Removing the Basis Board

- Switch off the instrument and pull the mains plug.
- Dismounting the case (see page 3.53).

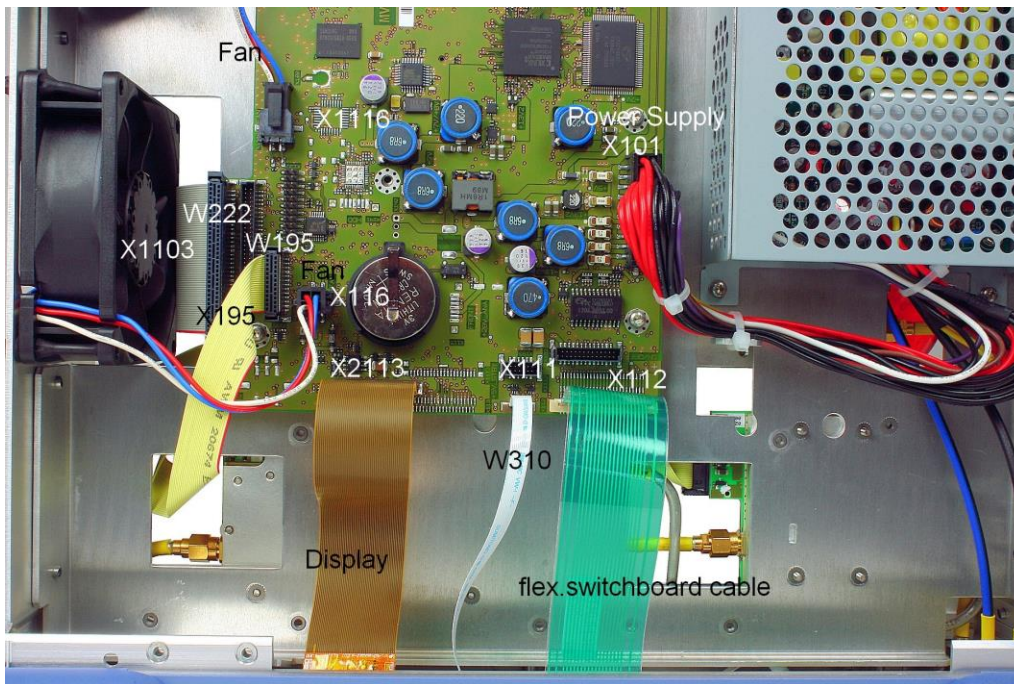

- Disconnect the two fan cables from X116 and X1116 and the power supply cable from X101 (Remove the plastic tie before disconnecting the cable).
- Disconnect the display flex. cable from X2113, W310 from X111, W222 (BB-RF-Board cable) from X1103 and the flex. switch board cable from X112.

NOTICE

If an option R&S SMB-B30 or the ASATT is installed, remove the cable W195 (1406.9222.00) or the cable W983 (1406.9680.00) from X195.

- Unscrew one combination screw (0041.1653.00) and two screws (0041.1653.00) from the IEC-connector at the back of the instrument.



- Unscrew the six combination screws (0041.1653.00) - red marked - on the basis board.
- Remove the basis board (by turning it up towards the front and pulling it out and upward).
- Remove the SIM Card from the basis board.

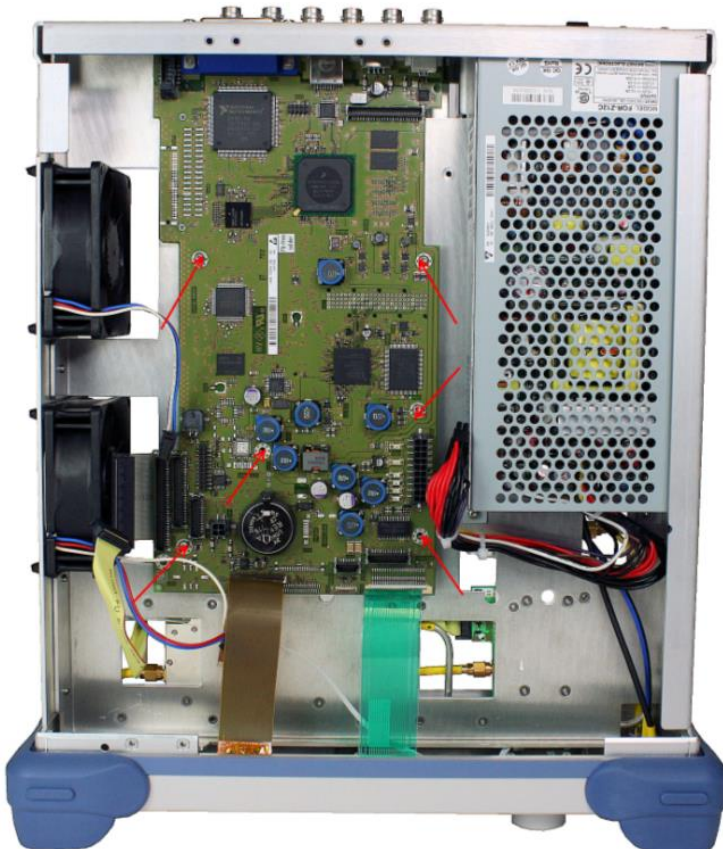

3.3.7.2 Installing the Basis Board

- Insert the SIM Card into the SIM Card holder on the new basis board (see page 3.66).
- Place the screw angle (1090.3230.00) on the IEC Connector.
- To insert the new basis board, proceed in the reverse order.
- Connect all cables (fans, power supply) and also the flex. cables W310, W222 and the flex. switchboard cable.

3.3.7.3 Replacing the Battery (G1)

- The lithium battery is accommodated on the basis board.

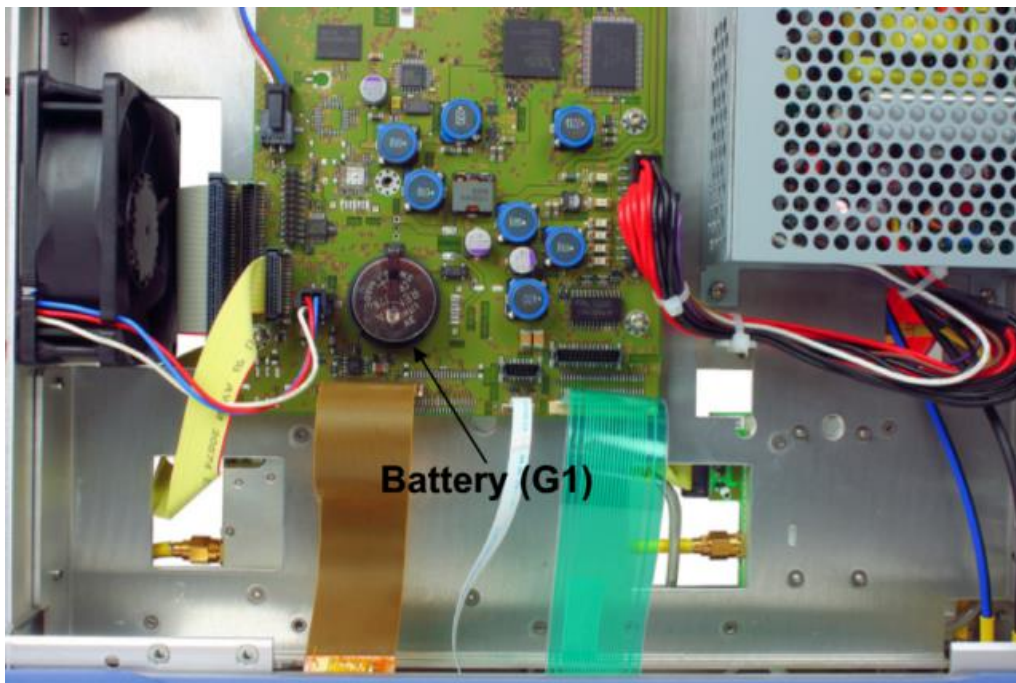

⚠ CAUTION**Danger of injury**

Lithium batteries must not be exposed to high temperatures or fire.

Keep away from children.

If the battery is replaced improperly, there is danger of explosion. Only replace the battery by R&S type (see also "[Overview of the Modules](#)", page 3.52).

Lithium batteries are hazardous waste and must be disposed of in dedicated containers.

Do not short-circuit the battery!

- Carefully lift and pull out the battery.

Note:

3.0 V lithium battery (Ø 24,5 mm * 7,7 mm , type CR2477N),
see also "[Overview of the Modules](#)", page 3.52.

- Insert new battery into holder below the spring.

Note:

The positive pole (+) of the battery should point upwards.

3.3.7.4 Replacing the SIM Card

NOTICE

When changing the basis board, you have to remove the SIM card.

The SIM card is part of your instrument and will not be replaced by Rohde & Schwarz if lost. Therefore, always keep the SIM card with you.

- Remove the basis board (see page 3.62).
The SIM card is located on the rear of the basis board.
- Open the latch of the SIM card holder by sliding the retaining bracket toward OPEN.

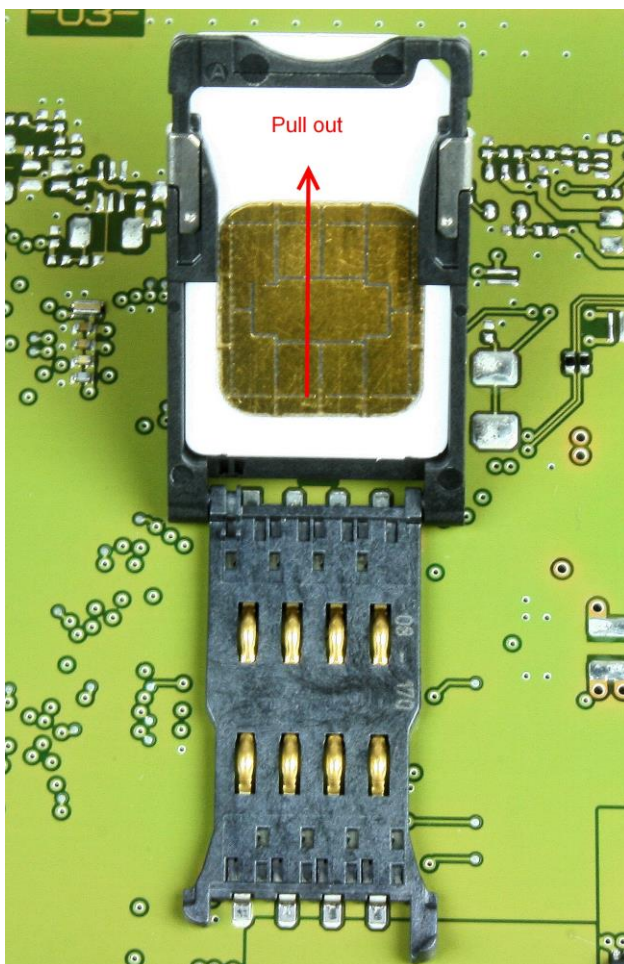

- Flip the SIM card holder upward and remove the SIM card.
- To install the SIM card, proceed in the reverse order.

3.3.8 Replacing the RF-Board (A200)

3.3.8.1 Removing the RF-Board



If the R&S SMB-B1 (Reference Oscillator) or R&S SMB-B1H (Reference Oscillator High Performance) option is installed, uninstall this option first (see [Replacing the Reference Oscillator Option R&S SMB-B1/B1H \(A210\)](#)).

- Switch off the instrument and pull the mains plug.
- Dismounting the case (see page 3.53).
- Disconnect the RF cables W212, W214, W215 and the flex. strip W222.

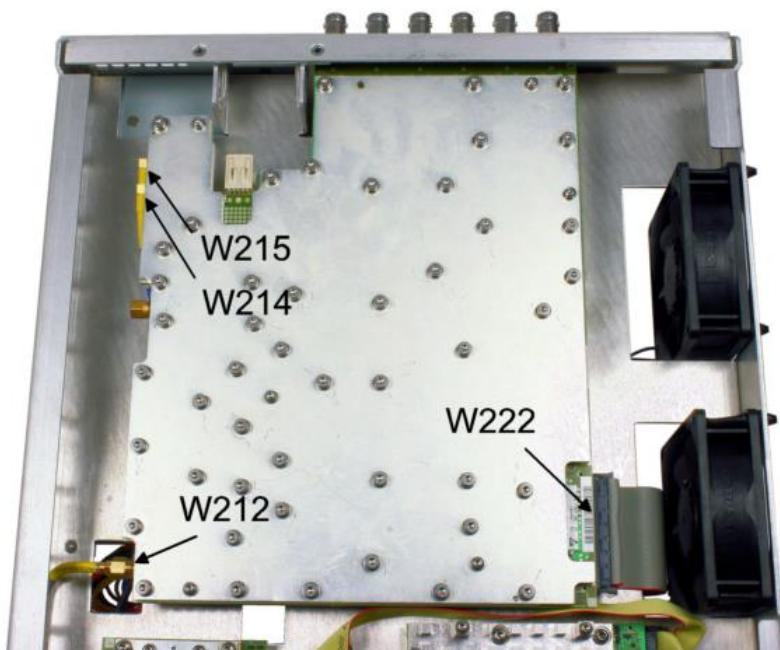

- Remove the six nuts of the BNC-connectors.



- Undo six screws (5302.0431.00) on the RF-board and remove the board.

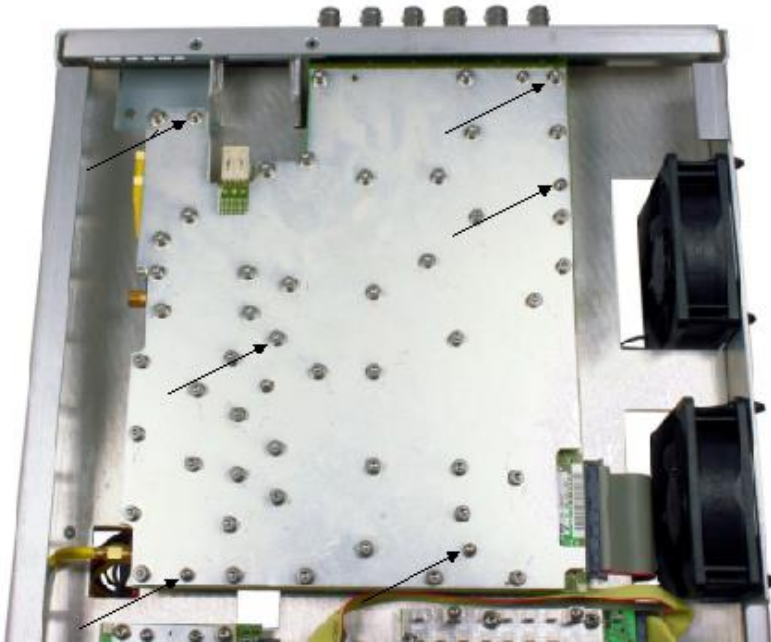

3.3.8.2 Installing the RF-Board

- Place the RF-Board into the R&S SMB-Frame in the right position and screw it with six screws (5302.0431.00).
- Screw the BNC-Connectors with the nuts and reconnect the RF cables (W212 (60 Ncm), W214, W215) and the flex. cable W222.

3.3.9 Replacing the Power Supply (A50)

3.3.9.1 Removing the Power Supply

- Switch off the instrument and pull the mains plug.
- Dismounting the case (see page 3.53).
- Remove connector X101 from the basis board.
- Cut the cable tie (0015.9038.00).
- Unscrew three combination screws (0041.1653.00) on the back of the instrument.
- Unscrew two combination screws (0041.1653.00) at the power supply, pull forward the module and remove it.

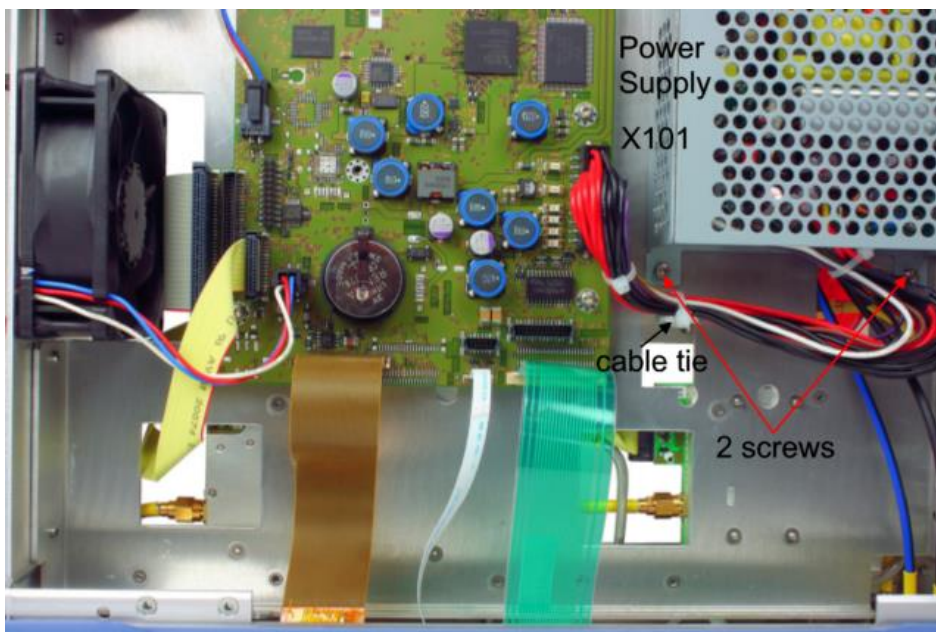

3.3.9.2 Installing the Power Supply

- Place the power supply in the instrument and screw it with two combination screws (0041.1653.00) at the power supply trough.
- Fix the power supply at the back of the instrument with three combination screws (0041.1653.00).
- Fix the power supply cable with a cable tie (0015.9038.00).

3.3.10 Replacing the Fan Unit (E1, E2)

- Switch off the instrument and pull the mains plug.
- Dismount the case (see page 3.53).
- Disconnect the fan cables from X116 and X1116 and push the rubber pins (1146.2161.00) through the trough.
- Install the new fan and proceed in the reverse order.
- Cut off the unnecessary rubber from the pins which extend outside the instrument casing, see also [“Overview of the Modules”](#), page 3.52.

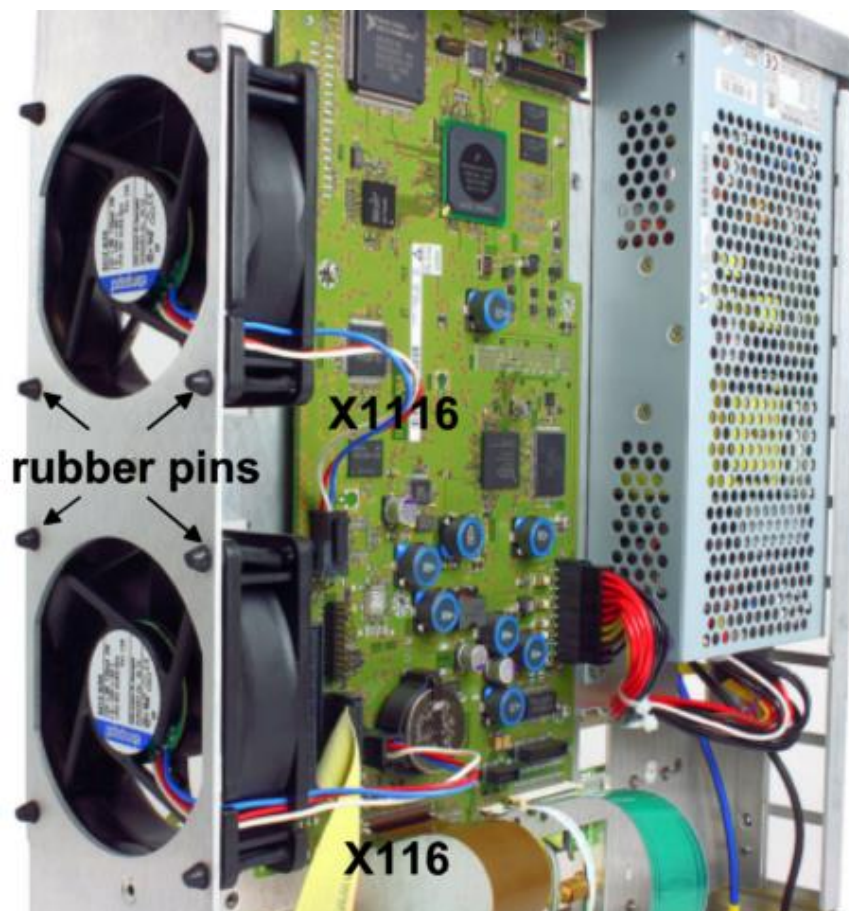

3.3.11 Replacing the Reference Oscillator Option R&S SMB-B1/B1H (A210)

3.3.11.1 Removing the Reference Oscillator

- Unscrew the three screws (0041.1653.00) fixing the option.
- Carefully remove the reference oscillator (1407.3105.02 or 1407.3105.03).



3.3.11.2 Installing the Reference Oscillator

- Carefully plug in the reference oscillator as far as possible.
- Fix the option with three screws.

3.3.12 Replacing the ASATT 13 GHz included in Option R&S SMB-B112 (A950)

3.3.12.1 Removing the ASATT 13 GHz

- Switch off the instrument and pull the mains plug.
- Dismount the case (see page 3.53).
- Unscrew the four combination screws (3584.5502.00) and disconnect the two RF cables W220 (1406.9268.00) and W221 (1406.9274.00) and the flat cable W195 (1406.9222.00).
- If R&S SMB-B30 (Reverse Power Protection) is installed, disconnect RF cables W981 (1406.9516.00) and W220 (1406.9268.00) and the flat cable W983 (1406.9680.00).
- If R&S SMB-B112L is installed, remove cable W212 (1406.9322.00).

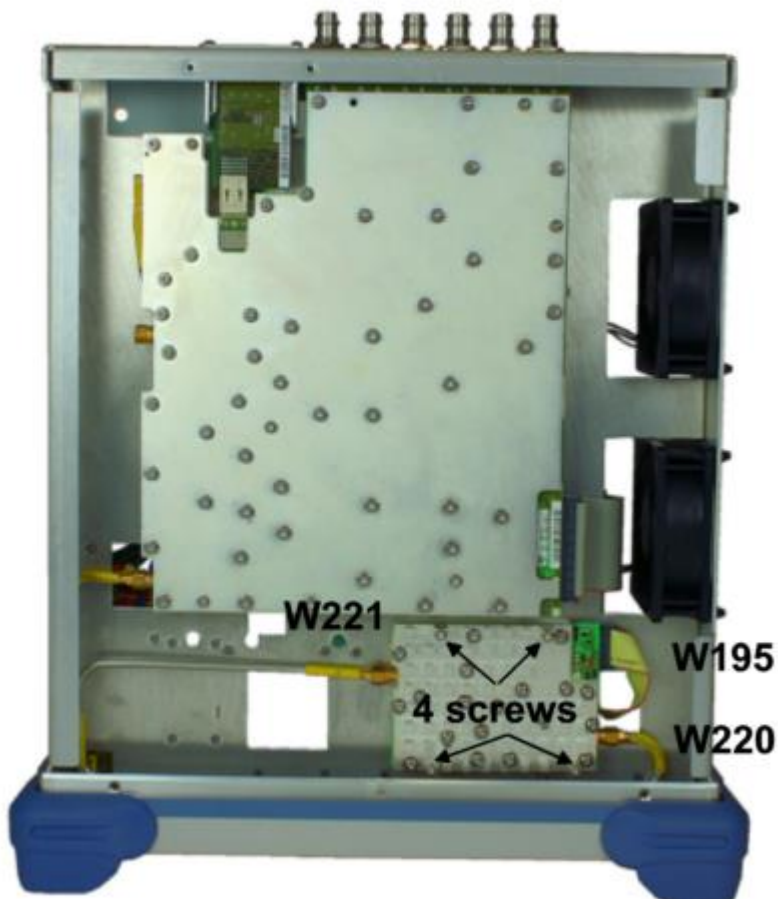

3.3.12.2 Installing the ASATT 13 GHz

- Carefully plug in the ASATT 13 GHz.
- Screw the four combination screws (3584.5502.00) and connect the two RF cables W220 (1406.9268.00) and W221 (1406.9274.00) and the flat cable W195 (1406.9222.00).
- If R&S SMB-B30 (Reverse Power Protection) is installed, connect RF cables W981 (1406.9516.00) and W220 (1406.9268.00) and the flat cable W983 (1406.9680.00).

3.3.13 Replacing the Reverse Power Protection included in Option R&S SMB-B30 (A980)

3.3.13.1 Removing the Reverse Power Protection

- Switch off the instrument and pull the mains plug.
- Dismount the case (see page 3.53).
- Disconnect the two RF cables W982 (1406.9480.00) and W981_1 or W981 (1406.9497.00 or 1406.9516.00) and the flat cable W983 (1406.9680.00) or W195 (1406.9222.00).
- Unscrew the 4 screws (5302.0431.00) and remove it.

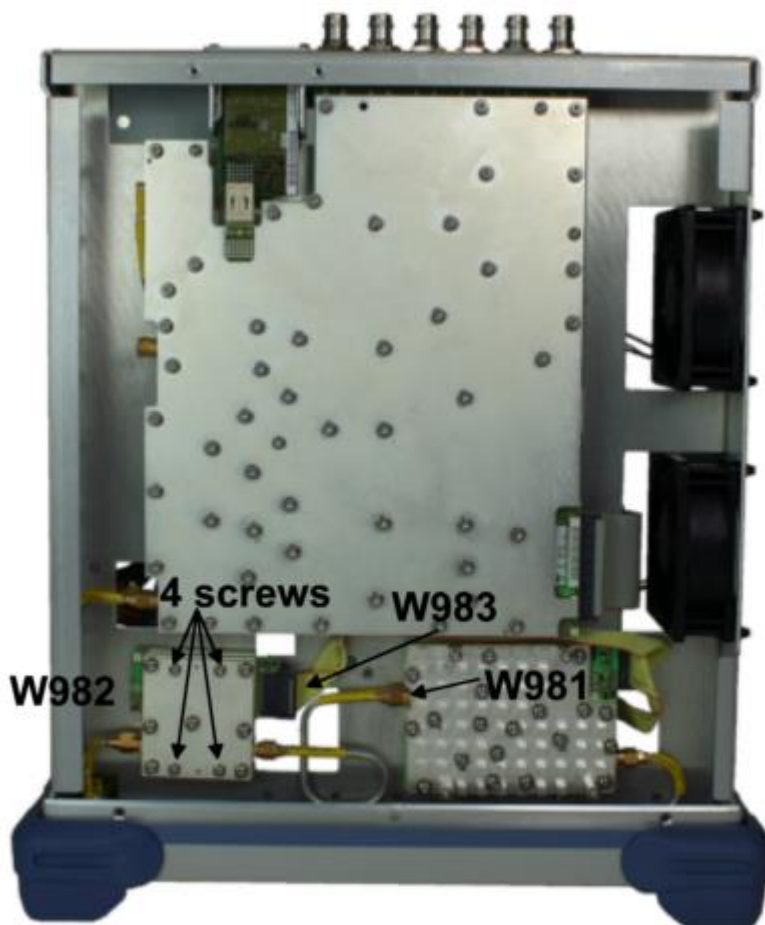

3.3.13.2 Installing the Reverse Power Protection

- Carefully plug in the Reverse Power Protection
- Screw it with the four screws (5302.0431.00) and connect the two RF cables W982 (1406.9480.00) and W981_1 or W981 (1406.9497.00 or 1406.9516.00) and the flat cable W983 (1406.9680.00) or W195 (1406.9222.00).

3.3.14 Replacing the RF Board 20 GHz (A220), 1406.7407.02 (included in options R&S SMB-B120/-B131/-B140/-B140N)

3.3.14.1 Removing the RF Board 20 GHz

- Switch off the instrument and pull the mains plug.
- Dismount the case (see page 3.53).
- Disconnect the SMP plugs and the hex-nuts. In case of R&S SMB-B120 one of the hex-nuts is a protection cap (1066.2095.00) - keep this for the new RF Board 20 GHz.
- Unscrew the four combination screws (5302.0431.00) and take them out. Lift the downholder cable (1407.0187.00) and take it out.

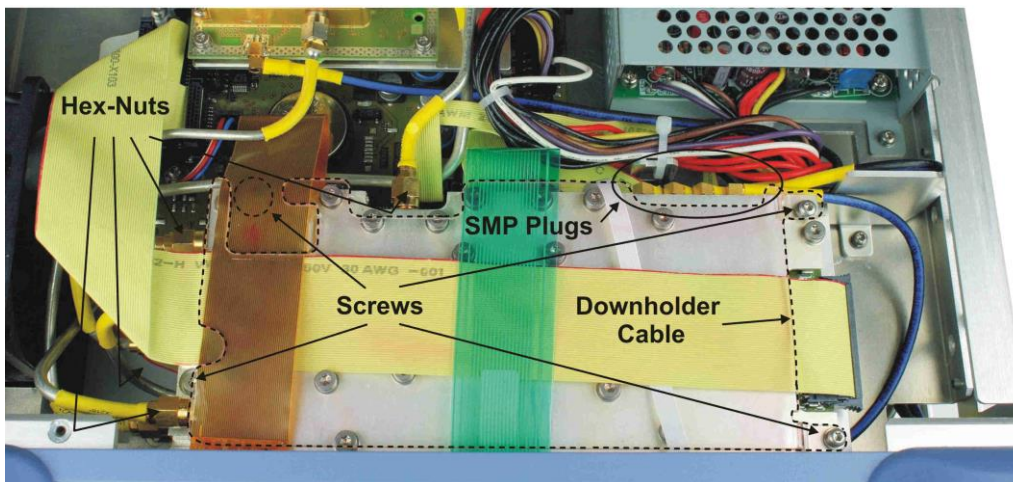

- Disconnect the flex. cables W103 (1407.0112.00) from X222, W310 from X111, display cable from X2113 and the flex. switchboard cable from X112.
- Take out the RF Board 20 GHz.

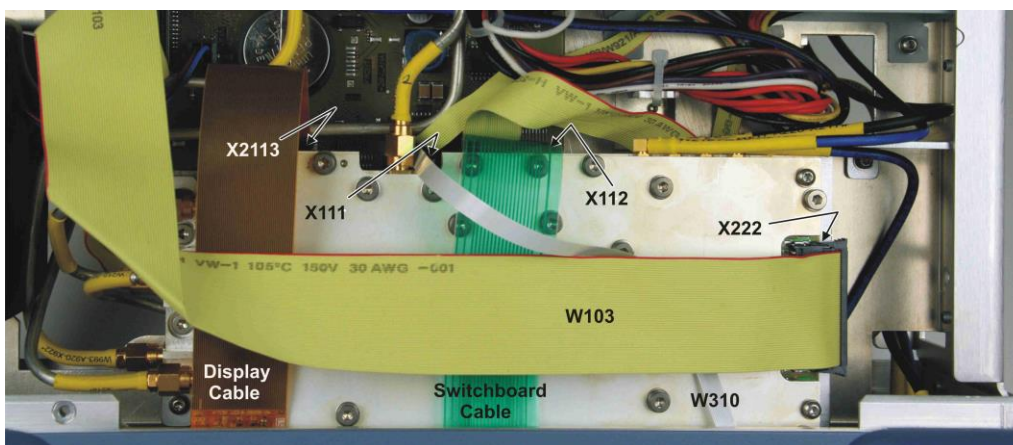

3.3.14.2 Replacing the RF Board 20 GHz

- Replace the RF Board and reassemble in reverse sequence. Make sure the hex-nuts and the protection cap in case of R&S SMB-B120 is remounted.
- Take care of the flex. cable W310.
- If necessary see page 3.74 for reconnecting flex cables.
- Reconnect the SMP plugs as described.

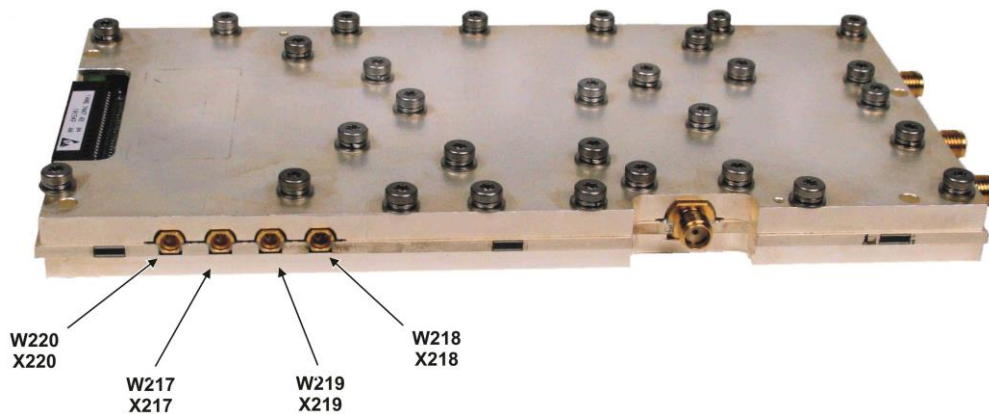

3.3.15 Replacing the HP20 (A970) 1407.1290.02 (included in options R&S SMB-B31 and R&S SMB-B32)

3.3.15.1 Removing the HP20 module

- Switch off the instrument and pull the mains plug.
- Dismount the case (see page 3.53).
- Remove RF Board 20 GHz (see page 3.74).
- Unscrew the 5 combination screws (3584.5502.00, 4x / 0041.1630.00, 1x) and take them out.
- Lift and remove the holder RF Board 20.

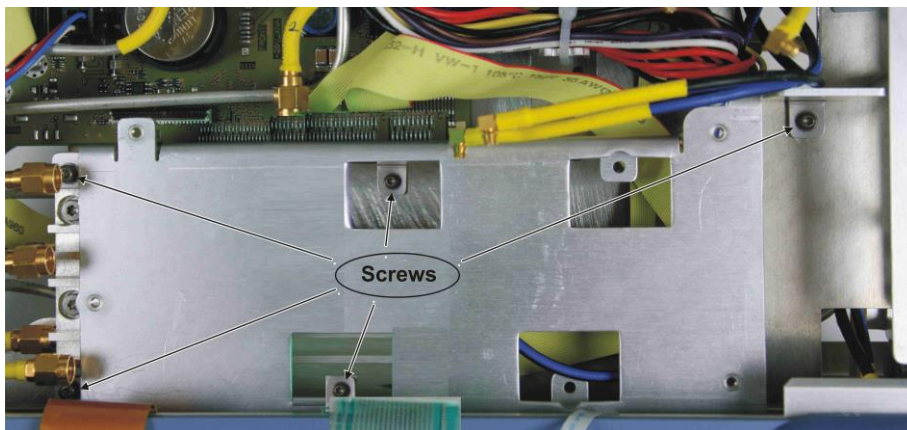

- Unplug the two hex-nuts, the SMP plug of W220 (1407.0170.00) and the cables W928 (1407.0193.00) and W192 (1406.9768.00) and remove the HP20 module.

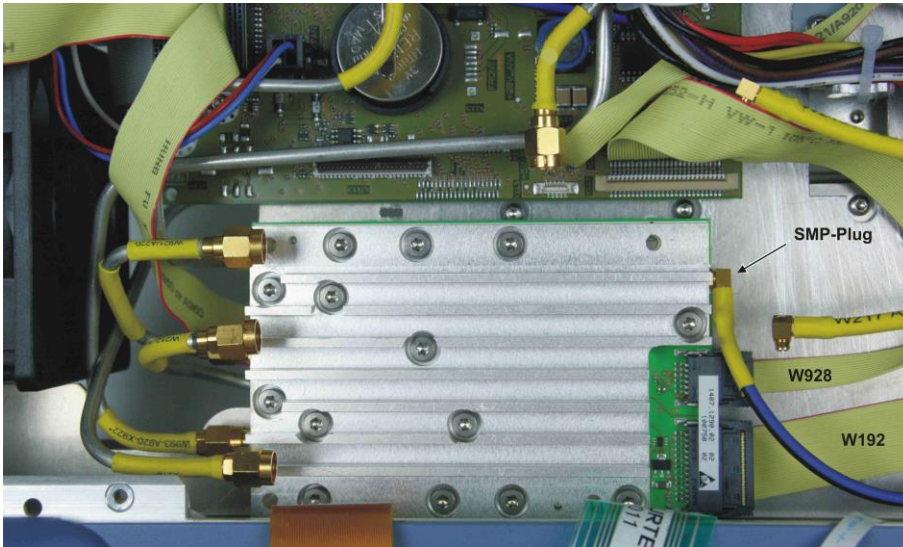

3.3.15.2 Replacing the HP20 module

- Replace the HP20 module and reassemble the unit in reverse sequence.

3.3.16 Replacing the Filter20 (A920) 1407.1690.02 (included in options R&S SMB-B25 and R&S SMB-B26)

3.3.16.1 Removing the Filter20 module

- Switch off the instrument and pull the mains plug.
- Dismount the case (see page 3.53).
- Remove RF Board 20 GHz (see page 3.74).
- Unscrew the 7 combination screws (3584.5502.00, 6x / 0041.1630.00, 1x) and take them out.
- Lift and remove the holder RF Board 20.

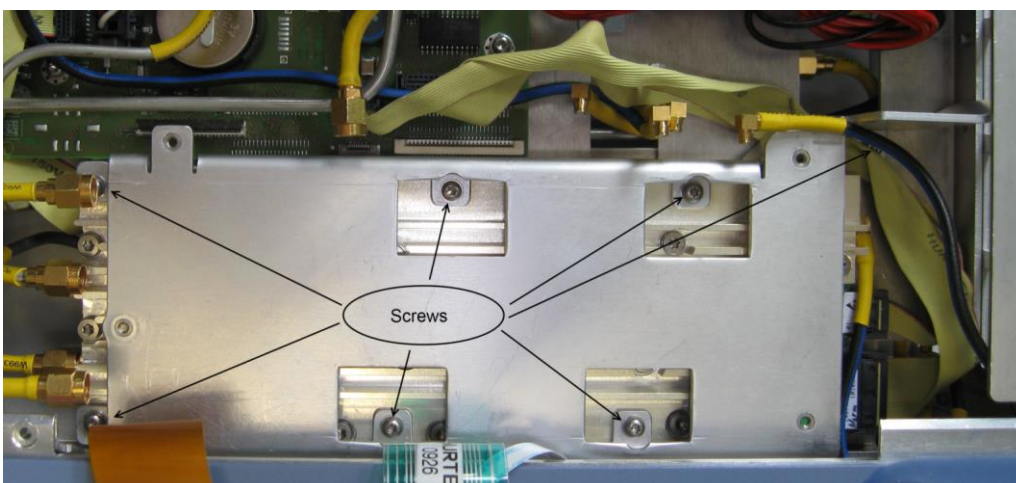

- Unplug the two hex-nuts, the SMP plug of W220 (1407.0170.00) and the cables W928 (1407.0193.00) and W192 (1406.9768.00) and remove the Filter20 module.

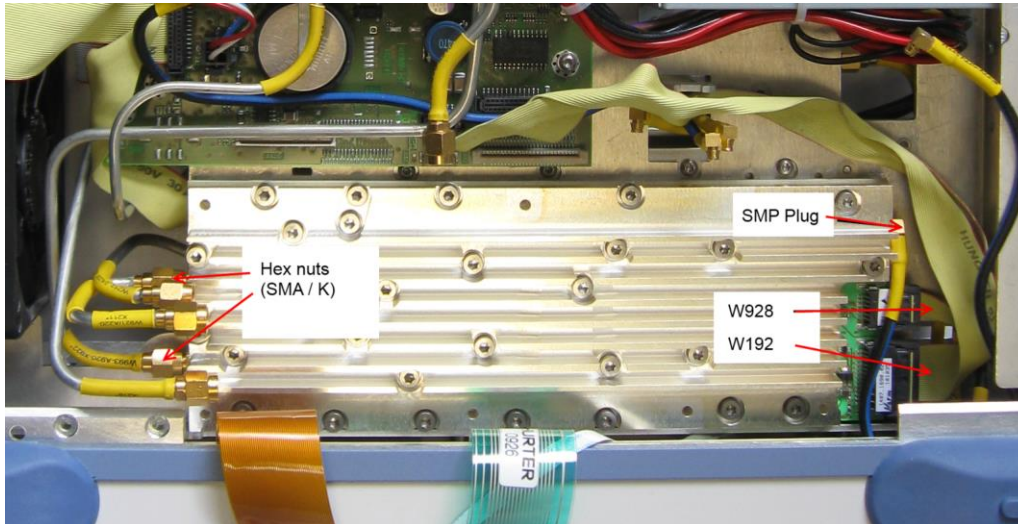

3.3.16.2 Replacing the Filter20 module

- Replace the Filter20 module and reassemble the unit in reverse sequence.

3.3.17 Replacing the Step Attenuator (A960) 1170.0094.02 / 1170.0113.02 (included in options R&S SMB-B120/-B131/-B140/-B140N)

3.3.17.1 Removing the step attenuator

- Switch off the instrument and pull the mains plug.
- Dismount the case (see page 3.53).
- Disconnect the flex. cable W195 (1406.9222.00) from X2 and the two hex-nuts.
- Unscrew the two combination screws (0041.1630.00) and take out the step attenuator.
- Unscrew four screws (1148.2617.00) from bottom side of step attenuator and remove the attenuator panel (1406.9245.00).

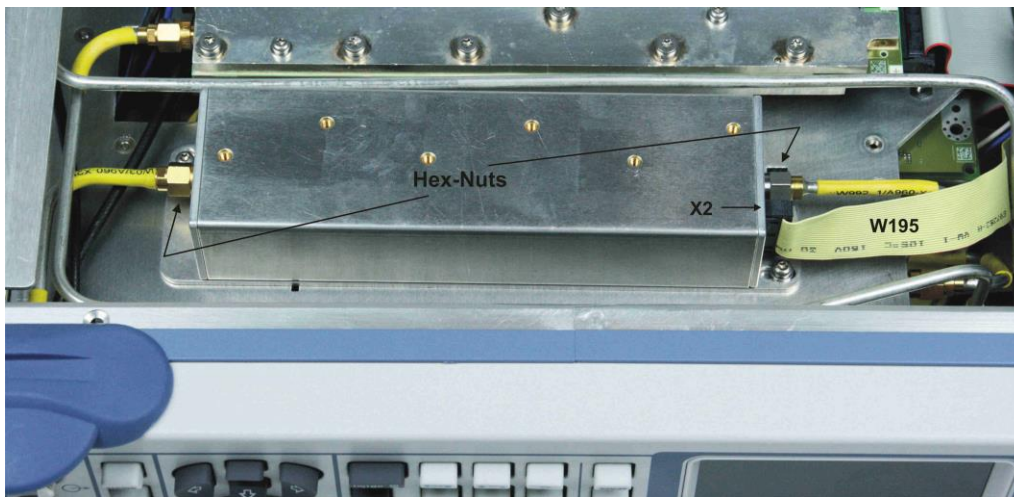

3.3.17.2 Replacing the step attenuator

- Replace the step attenuator and reassemble in reverse sequence.

3.3.18 Replacing the Doubler FD40 (A820) 1312.1006.02/.27/.31 (included in R&S SMB-B131/-B140/-B140N)

3.3.18.1 Removing the Doubler FD40

- Switch off the instrument and pull the mains plug.
- Dismount the case (see page 3.53).
- Disconnect the flex. cable W223 (1407.0129.00) from X222, the three hex-nuts and cable W219 (1406.9748.00) from the SMP-plug.
- Unscrew the four combination screws (1096.5205.00) and take out the doubler FD40.

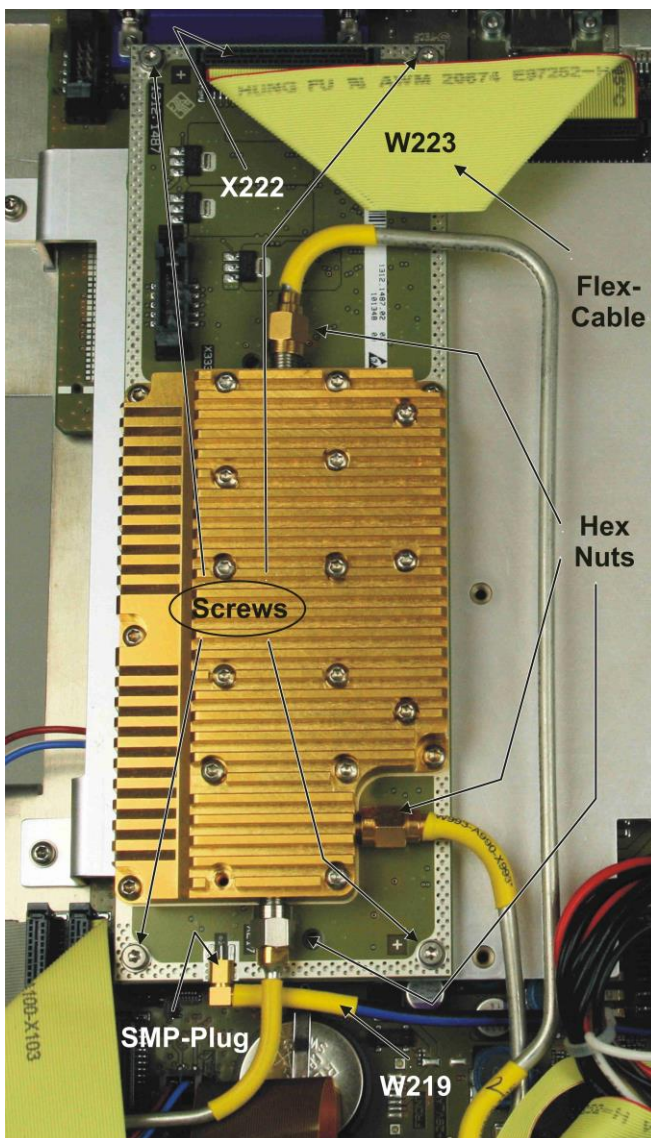

3.3.18.2 Replacing the Doubler FD40

- Replace the doubler FD40 and reassemble in reverse sequence.

3.3.19 Replacing the Doubler FD40 P (A990) 1315.0500.02/.27/.31 (included in option R&S SMB-B32 High Output Power)

3.3.19.1 Removing the Doubler FD40P

- Switch off the instrument and pull the mains plug.
- Dismount the case (see page 3.53).
- Disconnect the flex. cable W223 (1407.0129.00) from X222, the three Hex-Nuts and cable W219 (1406.9748.00) from the SMP-plug.
- Unscrew the two combination screws (0048.8218.00). For avoiding electrical damage keep them for replacing exactly there.
- Unscrew the four combination screws (1096.5205.00) and take out the doubler FD40P.

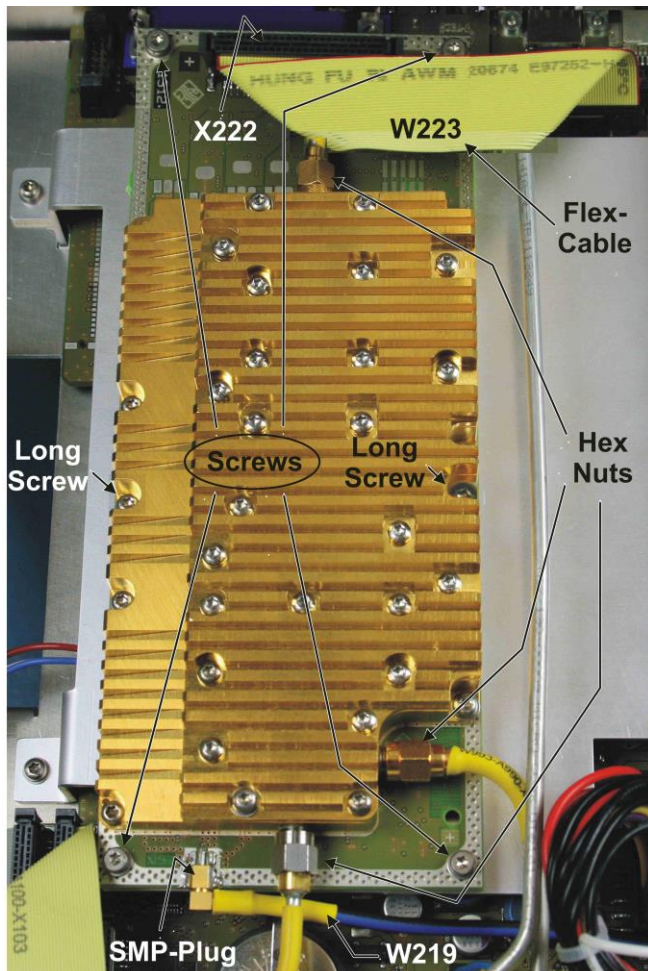

3.3.19.2 Replacing the Doubler FD40P

- Replace the doubler FD40P and reassemble in reverse sequence.
- Take care of the right position for the long combination screws for avoiding electrical damage.

Contents - Chapter 4 "Software Update/Installing Options"

- 4 Software Update / Installing Options4.1
 - 4.1 Installation of New R&S SMB Firmware.....4.1
 - 4.2 Installing the Options4.3
 - 4.2.1 Hardware Options4.3
 - 4.2.2 Software Options.....4.3

4 Software Update / Installing Options

This chapter contains information on firmware update and installing options to the R&S SMB. Additional manuals obtained together with a firmware update or with subsequently acquired options can be filed here

NOTICE



Possible impairment of the functioning of the instrument

The instrument is equipped with the Linux operating system. It is thus possible to install commercial off-the-shelf (COTS) software in the instrument. The use and installation of COTS software may impair the instrument function. For this reason, we recommend that you only execute programs tested by Rohde&Schwarz with regard to their compatibility with the instrument software. In certain cases, the use of these programs can impair the performance of the instrument.

The drivers and programs used in the instrument under Linux have been adapted to the test instrument. Existing instrument software must only be modified with update software released by Rohde & Schwarz.

4.1 Installation of New R&S SMB Firmware

Your R&S SMB is delivered with the latest firmware version available. Firmware updates as well as the Release Notes describing the improvements and modifications are provided on the Internet at the download site of the R&S SMB homepage <http://www.rohde-schwarz.com/product/smb100a>. This homepage always offers the latest information on your signal generator, e.g. also on **changes of the firmware update procedure**.

Firmware updates always are delivered in one single file with a filename starting with "SMB_" and ending in ".rsu". The version numbers in the filename vary with each update.

Firmware update: SMB_x.xx.xx.rsu

Preparation of firmware update

The installation of a new firmware version is performed via the USB interface. A deinstallation of the old firmware is not necessary. The update file has to be downloaded from the Internet to a PC. From there the file should be transferred to the root directory of a memory stick which will later be plugged into the USB interface of the instrument. The firmware update is performed while the instrument is running. The new firmware will be loaded right after the update process.

If the instrument "sees" a memory stick at its USB interface, it offers all versions stored on the memory stick for selection. Thus, an upgrade or downgrade of the firmware is possible at any time.

Installing the firmware

NOTICE**Risk of impairment of instrument function!**

*It is strongly recommended to **do no firmware downgrade below** the version the device was originally delivered with. Improved module revisions as well as modified structure of calibration data may not be supported by previous firmware versions.*

To avoid impairment of instrument functions, the update of the firmware must not be cancelled and the instrument must not be switched off during this update.

NOTICE**Risk of damage for device under test!**

*During the first restart after upgrading the firmware the instrument automatically performs internal adjustments. While adjusting, assemblies **without step attenuator** (e.g. R&S SMB-B112L/B120L/B140L) temporarily provide high power at the RF plug. This may cause damage to the device under test (DUT). So it is recommended to disconnect the DUT and connect a 50 ohm termination until instrument is operational with the new firmware.*

1. Switch on the instrument and wait until it is operational.
2. Plug in the memory stick which contains the update file (previously downloaded from the Internet) to the USB interface of the instrument.
3. Wait until the software update dialog appears and confirm the update.
4. Select the firmware version to be installed with the cursor up/down keys and press the rotary knob to activate your selection. The selected version will be installed.
5. Wait until the software update completed message appears.
6. Remove USB stick and press any key to switch off instrument.
7. Restart instrument. While the new/updated firmware is starting, internal adjustments are performed automatically.
 - To successfully perform internal adjustments, a valid reference frequency is required. If internal adjustments fail, check reference oscillator settings (**SETUP** **Reference Oscillator**) and restart internal adjustments manually. Press the **SETUP** key on the instrument front panel, select **Internal Adjustments** and execute **Adjust All**. Adjustments may take several minutes.

Adjustments requiring external measurement equipment are not affected by the firmware update and need not to be performed.

4.2 Installing the Options

A list of all available R&S SMB options is provided in the data sheet and on the internet <http://www.rohde-schwarz.com/product/smb100a>.

4.2.1 Hardware Options

Installation and replacement of hardware options is described in chapter 3 of this service manual. Please also note the mounting instructions enclosed with the options. These mounting instructions can be filed at this place in the service manual and are thus easily available whenever they are required.

DANGER

Danger of shock hazard



For module replacement, ensure that the instrument is switched off and disconnected from the power supply by removing the plug from the AC and DC power connector.

Read all safety instructions at the beginning of this manual carefully before module replacement.

NOTICE

Danger of damage to components of the module



Protect the operational site against electrostatic discharge to avoid damage to electronic components of the modules. For details refer to the safety instructions at the beginning of this manual.

The **[SETUP] Installed Options** menu provides information on the already installed options.

4.2.2 Software Options

All available software options are already included in the latest firmware. They are ready to operate after they are enabled by means of a key code supplied with the option.

Only if the R&S SMB is equipped with an older firmware version, a firmware update prior to enabling the software option may be required. The information on the valid firmware versions for the purchased software option is provided together with the option.

The key code is to be entered into the **[SETUP] Manage Licence Keys...** menu.

The **[SETUP] Installed Options** menu provides information on the already installed options.

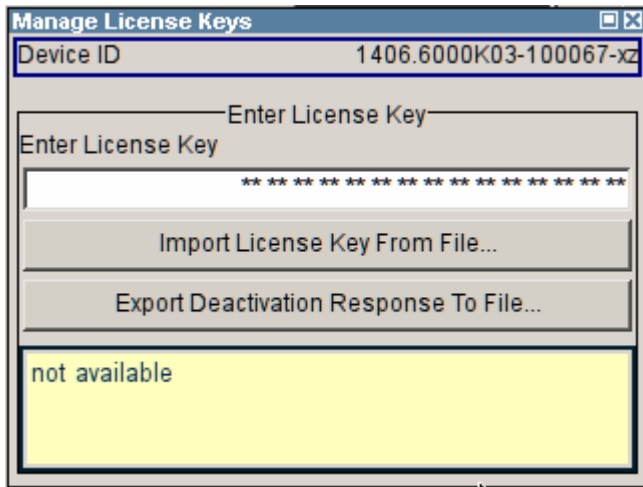

Contents - Chapter 5 "Documents"

- 5 Documents5.1
 - 5.1 Spare Parts5.1
 - 5.2 Available Power Cables5.2

5 Documents

This chapter contains the spare parts list and the documents for the complete R&S SMB unit. For general information about spare parts for our products please refer to the sheet "Procedure in Case of Service and Ordering of Spare Parts" at the beginning of this manual

5.1 Spare Parts

The stock numbers necessary for ordering replacement parts and modules can be found in the component lists further down.

DANGER**Danger of shock hazard**

For module replacement, ensure that the instrument is switched off and disconnected from the power supply by removing the plug from the AC and DC power connector.

Read all safety instructions at the beginning of this manual carefully before module replacement.

NOTICE**Risk of damage to the module**

When shipping a module be careful to provide for sufficient mechanical and antistatic protection.

5.2 Available Power Cables

Table 5-1 List of power cables available

Stock No.	Earthed-contact connector	Preferably used in
DS 0006.7013.00	BS1363: 1967' 10 A, 250 V complying with IEC 83: 1975 standard B2	Great Britain
DS 0006.7020.00	Type 12, 10 A, 250 V complying with SEV-regulation 1011.1059, standard sheet S 24 507	Switzerland
DS 0006.7036.00	Type 498/13, 10 A, 250 V complying with US-regulation UL 498, or with IEC 83	USA/Canada
DS 0041.4752.00	GB2099, GB1002, 10 A, 250 V approvals CCC	China
DS 0041.6232.00	JIS C 8303, 7A, 125 V AC approvals PSE (JET)	Japan
DS 0006.7107.00	Type SAA3, 10 A, 250 V, complying with AS C112-1964 Ap.	Australia
DS 0025.2365.00 DS 0099.1456.00	DIN 49 441, 10 A, 250 V, angular DIN 49 441, 10 A, 250 V, straight approvals VDE, ÖVE, CEPEC, KEMA, S, D, N, FI, LCIE, IMQ, UCIEE	Europe (except Switzerland)

Spare Parts List

Für diese Unterlage behalten wir uns alle Rechte vor.
 Ausgedruckte Dokumente unterliegen nicht dem Änderungsdienst.
 For this document all rights are reserved.
 Printed documents are not subject to revision

Pos.-Nr. ItemNo	Menge Quantity	ME Unit	El.Kennz Ref.Des.	Benennung / Bezeichnung Designation	Z	Sachnummer Stock No.	Ersatzteil Subst.part	BA	VH
				ACHTUNG EGB/ATTENTION ESD *VARIANTENERKLAERUNG *EXPLANATION OF MODELS VAR02=GRUNDVARIANTE MOD02=BASIC MODEL					
10	0	S		ZS ERSATZTEILLISTE VORHANDEN SPARE PARTS LIST AVAIL Beachte / Note 1406.6030.01 ST		0999.9684.00		M	O
50	0	S		PH BEMERKUNG NOTE Stücklisten-Positionen entsprechen den Einträgen in 1406.9045.01 D Blatt 1 BOM items correspond to entries in 1406.9045.01 D sheet 1		0999.9610.00		B	O
100	1	S		ZM CHASSIS SMB 13/20/40 CHASSIS SMB 13/20/40 for SMB-B112 (1407.2109.02) SMB-B112L (1407.2150.02) and SMB-B120, SMB-B120L, SMB-B140, SMB-B140L (1407.2209.02, 1407.2250.02, 1407.2309.02, 1407.2350.02)	Z	1406.9080.03		M	P
110	2	S	E1	DX LUEFTEREINHEIT FAN UNIT	Z	1406.6330.00	X	M	P
145	1	S		BC SMARTCARD SLE66 V4.4 SIM FORMAT SMARTCARD SLE66 V4.4 SIM FORMAT vor Einbau von A100 auf A100 Loetseite stecken / insert before installation of A100 to A100 solder side		3586.7860.00		B	I
150	1	S	A100	ED BASISBOARD 3 BASIS BOARD 3	Z	1406.6800.06	X	M	P
151	1	S	G1.2	EB CR2477N BATT LI-MNO2 3.0V 0.95AH BATTERY		4052.5673.00	X	B	O
160	7	S		VS 6900/ISR-M2.5X8-A2 COMBI SCREW 6900/ISR-M2.5X8-A2		0041.1653.00		B	T
200	1	S	A50	NJ SCHALTNETZTEIL AC 90-264V 120W POWER SUPPLY für alle Optionen nur nicht für SMB-B26 (1407.1760.02) for all options but not for SMB-B26 (1407.1760.02)		1406.7336.00	X	B	V
205	1	S		DZ KABELBI.RD 1 BIS 25 B2 CABLETIE		0015.9038.00		B	O
210	5	S		VS 6900/ISR-M2.5X8-A2 COMBI SCREW 6900/ISR-M2.5X8-A2		0041.1653.00		B	T
250	0	S	A200	ED RF BOARD 13 GHZ RF BOARD 13 GHZ	Z	1406.7307.02	X	M	P
251	1	S	A200	ED RF BOARD2 13 GHZ RF BOARD2 13 GHZ	Z	1406.7371.02	X	M	P
260	6	S		VS 6900/ISR-M2.5X20-A2 COMBI SCREW 6900/ISR-M2.5X20-A2		5302.0431.00		B	T
262	6	S		FJ FAECHERSCHEIBE SERRATED LOCKWASHER		3583.1578.00		B	O
265	6	S		FJ MUTTER HEX 16 1/2 -28UNEF HEX 16 NUT 1/2 -28UNEF		3585.2707.00		B	B



ROHDE & SCHWARZ

Benennung/Designation

**GRUNDEINHEIT SMB MICROWELLE
BASIC UNIT SMB MICROWAVE**

Sprach./Lang
de en

Ä.I. / C.I
13.00

Blatt/Sheet
1 of 2

Dokument Nr. / Document No.

1406.9045.01 ST

SMB

Datum/
Date

2013-03-15

Abt. /
Dept.

MTEK

Name /
Name

EI

Für diese Unterlage behalten wir uns alle Rechte vor.
 Ausgedruckte Dokumente unterliegen nicht dem Änderungsdienst.
 For this document all rights are reserved.
 Printed documents are not subject to revision

Pos.-Nr. ItemNo	Menge Quantity	ME Unit	El.Kennz Ref.Des.	Benennung / Bezeichnung Designation	Z	Sachnummer Stock No.	Ersatzteil Subst.part	BA	VH
400	1	S	A300	ZM FRONTEINHEIT SMB100A NEUES DISPLAY FRONTUNIT SMB100A NEW DISPLAY	Z	1406.7820.03	X	M	O
410	4	S		VS 965/ISR-M2.5X5-A4-PA 965/ISR-M2.5X5-A4-PA		1148.2752.00		B	T
420	1	S	W214	DV KABEL W214 MOD EXT - RFBO LANG CABLE W214 MOD EXT - RFBO LANG	Z	1406.9697.00		M	P
430	1	S	W215	DV KABEL W215 LF - RFBO LANG CABLE W215 LF - RFBO LANG	Z	1406.9700.00		M	P
440	1	S	W222	DY KABEL W222 BB-RF BOARD CABLE W222 BB-RF-BOARD	Z	1406.9200.00		M	L
507	1	S		KB RUECKWAND 2 REAR PANEL 2	Z	1406.6281.00		M	P
508	3	S		VS 6900/ISR-M2.5X6-A2 COMBI SCREW 6900/ISR-M2.5X6-A2		1148.3059.00		B	T
510	1	S		MZ BW2 TUBUS 2E3/4T400 SMB20/40 BW2 TUBE 2HU3/4D400 SMB20/40	Z	1406.9151.00		M	L
520	1	S		KR BW2-SCHUTZECK VO.LI.2E HART PROTECTIVE CORNER FRONT LEFT		1096.6618.00		B	V
530	1	S		KR BW2-SCHUTZECK VO.RE.2E HART PROTECTIVE CORNER FRONT RIGHT 2HU		1096.6624.00		B	V
540	1	S		KR BW2-SCHUTZECK HI.LI.2E HART PROTECTIVE COVER REAR LEFT 2HU		1096.6630.00		B	V
550	1	S		KR BW2-SCHUTZECK HI.RE.2E HART PROTECTIVE COVER REAR RIGHT 2HU		1096.6647.00		B	V
640	1	S		OS KC SCHILD SMB LABEL KC SMB geklebt auf Rückwand / glued to the rear wall		1406.6530.00		M	P
705	1	S		HS FONT MICROSOFT ARIAL WGL FONT MICROSOFT ARIAL WGL		3584.9795.00		B	O

 ROHDE & SCHWARZ	Benennung/Designation GRUNDEINHEIT SMB MICROWELLE BASIC UNIT SMB MICROWAVE			Sprach./Lang de en	Ä.I. / C./ 13.00	Blatt/Sheet 2 of 2
	SMB	Datum/ Date 2013-03-15	Abt. / Dept. MTEK	Name / Name EI	Dokument Nr. / Document No. 1406.9045.01 ST	

Für diese Unterlage behalten wir uns alle Rechte vor.
 Ausgedruckte Dokumente unterliegen nicht dem Änderungsdienst.
 For this document all rights are reserved.
 Printed documents are not subject to revision

Pos.-Nr. ItemNo	Menge Quantity	ME Unit	El.Kennz Ref.Des.	Benennung / Bezeichnung Designation	Z	Sachnummer Stock No.	Ersatzteil Subst.part	BA	VH
				ACHTUNG EGB/ATTENTION ESD *VARIANTENERKLAERUNG *EXPLANATION OF MODELS VAR02=6 GHZ AUSFUEHRUNG MOD02=6 GHZ MODEL VAR03=13 GHZ AUSFUEHRUNG MOD03=13 GHZ MODEL VAR04=20/40 GHZ AUSFUEHRUNG MOD04=20/40 GHZ MODEL					
10	0	S		ZS ERSATZTEILLISTE VORHANDEN SPARE PARTS LIST AVAIL Beachte / Note 1406.6030.01 ST		0999.9684.00		M	O
50	0	S		PH BEMERKUNG NOTE Stücklisten-Positionen entsprechen den Einträgen in 1406.7820.01 D Blatt 1 BOM items correspond to entries in 1406.7820.01 D sheet 1		0999.9610.00		B	O
720	1	S		MZ MONTAGEWANNE SMB MOUNTING THROUGH VAR 02	Z	1406.7536.00		M	P
722	1	S		ZN MONTAGEWANNE SMB 20/40 MOUNTING THROUGH SMB 20/40 VAR 03 04	Z	1406.9239.00		M	P
732	1	S	A330	ND TFT 3.5 QVGA DRGB LED 80MM KABEL TFT 3.5 QVGA DRGB LED 80MM VAR 02		3585.1400.00	X	B	B
734	1	S	A330	ND TFT 3.5 QVGA DRGB LED 180MM KABEL TFT 3.5 QVGA DRGB LED 180MM VAR 03 04		3586.0172.00	X	B	B
737	4	S		EK KONTAKTFEDER CONTACT SPRING	Z	1406.7713.00		M	P
743	1	S		MM DISPLAYRAHMEN OHNE SCHEIBE LCD FRAME		1406.7742.00		B	B
750	1	S		SF SCHALTMATTENSATZ SMB 2TEILE RUBBER KEYPAD SMB 2PARTS	Z	1406.7542.00	X	B	B
760	1	S	A320	SF SCHALTFOLE SMB FLEX. SWITCHBOARD VAR 02		1406.7559.00	X	B	B
762	1	S	A320	SF SCHALTFOLE SMB HOCHFREQUENT FLEX. SWITCHBOARD VAR 03 04		1406.9180.00	X	B	B
770	1	S		MM SCHUTZKRAGEN 9.6X13.9 SHROUD		0852.1234.00		B	O
795	1	S		MZ HALBLECH SMB NEUES DISPLAY HOLDING PLATE	Z	1406.7759.00		M	P
800	1	S		OK KRAGEN M. KLEBEPAD -		0852.1205.00		B	B
810	1	S		OK DREH.RD28 ACHS-RD6 KNOB		0852.1086.00		B	V
820	1	S	A310	ED ENCODER BOARD ENCODER BOARD	Z	1300.3044.02	X	M	P
830	1	S	W310	DF FLEX-STRIP 10P. R=0.5 FLEX-STRIP		1146.9150.00		B	B



ROHDE & SCHWARZ

Benennung/Designation

**FRONTEINHEIT SMB100A NEUES DISPLAY
FRONTUNIT SMB100A NEW DISPLAY**

Sprach./Lang
de en

Ä.I. / C.I
04.00

Blatt/Sheet
1 of 2

Dokument Nr. / Document No.

1406.7820.01 ST

SMB

Datum/
Date

2013-03-15

Abt. /
Dept.

1ZKS

Name /
Name

EI

Für diese Unterlage behalten wir uns alle Rechte vor.
 Ausgedruckte Dokumente unterliegen nicht dem Änderungsdienst.
 For this document all rights are reserved.
 Printed documents are not subject to revision

Pos.-Nr. <i>ItemNo</i>	Menge <i>Quantity</i>	ME <i>Unit</i>	El.Kennz <i>Ref.Des.</i>	Benennung / Bezeichnung <i>Designation</i>	Z	Sachnummer <i>Stock No.</i>	Ersatzteil <i>Subst.part</i>	BA	VH
832	1	S	W310	VAR 02 DF FLEX-STRIP 10P R=0.5 L=250 OBEN- OBE FLEX-STRIP 10POL VAR 03 04		1407.8113.00		B	B
840	10	S		VS 6900/ISR-M2.5X6-A2 COMBI SCREW 6900/ISR-M2.5X6-A2		1148.3059.00		B	T

 ROHDE&SCHWARZ	Benennung/ <i>Designation</i> FRONTEINHEIT SMB100A NEUES DISPLAY FRONTUNIT SMB100A NEW DISPLAY			Sprach./Lang de en	Ä.I. / C./ 04.00	Blatt/Sheet 2 of 2
	SMB	Datum/ Date 2013-03-15	Abt. / Dept. 1ZKS	Name / Name EI	Dokument Nr. / Document No. 1406.7820.01 ST	

Für diese Unterlage behalten wir uns alle Rechte vor.
 Ausgedruckte Dokumente unterliegen nicht dem Änderungsdienst.
 For this document all rights are reserved.
 Printed documents are not subject to revision

Pos.-Nr. ItemNo	Menge Quantity	ME Unit	El.Kennz Ref.Des.	Benennung / Bezeichnung Designation	Z	Sachnummer Stock No.	Ersatzteil Subst.part	BA	VH
				ACHTUNG EGB/ATTENTION ESD *VARIANTENERKLAERUNG +EXPLANATION OF VARIANTS *VAR02=GRUNDVARIANTE +VAR02=BASIC MODEL *VAR03=UNREGISTERED +VAR03=UNREGISTERED					
1019	1	S	A920	ED FILTER20G FILTER20G	Z	1407.1690.02		M	P
1022	1	S	W921	DW HF-KABEL W921 RFBO20-FILTER20 RF CABLE W921 RFBO20-FILTER20	Z	1406.9945.00	X	M	P
1024	1	S	W192	DY KABEL W192 FILTER/HP-BB 26POL CABLE W192 FILTER/HP-BB 26POL	Z	1406.9768.00	X	M	W
1026	1	S	W220_1	DV KABEL W220_1 RFBO20 - FILTER CABLE W220_1 RFBO20 - FILTER	Z	1407.0258.00	X	M	P
1028	1	S	W928	DY KABEL W928 FILTER/HP-BB 12POL CABLE W928 FILTER/HP-BB 12POL	Z	1407.0193.00	X	M	W
1035	3	S		VS 6900/ISR M2.5 X 20 A2 COMBI SCREW 6900/ISR M2.5 X 20 A2 bei neuem Chassis wird der Filter20G mit 7 Schrauben befestigt, bei altem Chassis nur mit 6 new chassis screw filter20G with 7 screws old chassis screw filter20G with 6 screws		5302.0431.00		B	T
1037	1	S	W980	DW HF-KABEL W980 FILTER-RFOUT RF CABLE W980 FILTER-RFOUT nur bei/ only if Option SMB-B120L 1407.2250.02	Z	1406.9897.00	X	M	P
1039	1	S	W922	DW HF-KABEL W922 FILTER-ATT44 RF CABLE W922 FILTER-ATT44 nur bei/ only if Option SMB-B120 1407.2209.02	Z	1406.9951.00	X	M	P
1050	1	S		PI BEILAGE FUER UNREG. LIZENZEN SUPPLEMENT FOR UNREG. LICENSES VAR 03		1171.3322.00		M	W



ROHDE & SCHWARZ

Benennung/Designation

SMB-B25 OBERWELLENFILTER
SMB-B25 LOW HARMONIC FILTER

Sprach./Lang
de en

Ä.I. / C.I
05.00

Blatt/Sheet
1 of 1

Dokument Nr. / Document No.

1407.1660.01 ST

SMB-B25

Datum/
Date 2015-12-14

Abt. /
Dept. 1GAK

Name /
Name HG

Für diese Unterlage behalten wir uns alle Rechte vor.
 Ausgedruckte Dokumente unterliegen nicht dem Änderungsdienst.
 For this document all rights are reserved.
 Printed documents are not subject to revision

Pos.-Nr. ItemNo	Menge Quantity	ME Unit	El.Kennz Ref.Des.	Benennung / Bezeichnung Designation	Z	Sachnummer Stock No.	Ersatzteil Subst.part	BA	VH
				ACHTUNG EGB/ATTENTION ESD *VARIANTENERKLAERUNG +EXPLANATION OF VARIANTS *VAR02=GRUNDVARIANTE +VAR02=BASIC MODEL					
202	1	S	A50	NJ SCHALTNETZTEIL AC 90-264V 150W POWER SUPPLY an Stelle von Pos. 200 Schaltnetzteil AC90-264V 1406.7336.00 aus Stückliste 1406.9045.01 instead of Pos 200 Power Supply AC90-264V 1406.7336.00 from part list 1406.7336.00		1406.7020.00	X	B	V
1019	1	S	A920	ED FILTER20G FILTER20G	Z	1407.1690.02		M	P
1022	1	S	W921	DW HF-KABEL W921 RFBO20-FILTER20 RF CABLE W921 RFBO20-FILTER20	Z	1406.9945.00	X	M	P
1024	1	S	W192	DY KABEL W192 FILTER/HP-BB 26POL CABLE W192 FILTER/HP-BB 26POL	Z	1406.9768.00		M	W
1026	1	S	W220_1	DV KABEL W220_1 RFBO20 - FILTER CABLE W220_1 RFBO20 - FILTER	Z	1407.0258.00	X	M	P
1027	1	S	W219	DY KABEL W192 FILTER/HP-BB 26POL CABLE W192 FILTER/HP-BB 26POL	Z	1406.9768.00		M	W
1028	1	S	W928	DY KABEL W928 FILTER/HP-BB 12POL CABLE W928 FILTER/HP-BB 12POL	Z	1407.0193.00	X	M	W
1030	1	S	W993	DW HF-KABEL W993 FILTER20-FD40P RF CABLE W993 FILTER20-FD40P	Z	1407.0158.00		M	P
1032	0	S		ZE DOUBLER FD40P DOUBLER FD40P bereits in Frequenzoption enthalten	Z	1315.0500.02		M	V
1034	1	S	W992_1	DW HF-KABEL W992_1 FD40P-ATT RF CABLE W992_1 FD40P-ATT nur bei/ only if Option SMB-B140 1407.2309.02	Z	1407.0164.00		M	P
1035	3	S		VS 6900/ISR M2.5 X 20 A2 COMBI SCREW 6900/ISR M2.5 X 20 A2 bei neuem Chassis wird der Filter20G mit 7 Schrauben befestigt, bei altem Chassis nur mit 6. new chassis screw filter20G with 7 screws old chassis screw filter20G with 6 screws		5302.0431.00		B	T
1036	1	S	W992	DW HF-KABEL W992 FD40P-RFOUT RF CABLE W992 FD40P-RFOUT nur bei/ only if Option SMB-B140L 1407.2350.02	Z	1407.0141.00		M	W
1038	1	S	W991	DW HF-KABEL W991 RFBO20-FD40P LO20 RF CABLE W991 RFBO20-FD40P LO20	Z	1407.0135.00		M	P
1040	2	S		VS HVC/ISR M2.5 X 16 A2 COMBI SCREW HVC/ISR M2.5 X 16 A2		0048.8218.00		B	B



ROHDE & SCHWARZ

Benennung/Designation

SMB-B26 OBERWELLENFILTER
SMB-B26 LOW HARMONIC FILTER

Sprach./Lang
de en

Ä.I. / C.I.
06.00

Blatt/Sheet
1 of 1

Dokument Nr. / Document No.

1407.1760.01 ST

SMB-B26

Datum/
Date 2015-07-21

Abt. /
Dept. 1GAK

Name /
Name HG

Für diese Unterlage behalten wir uns alle Rechte vor.
 Ausgedruckte Dokumente unterliegen nicht dem Änderungsdienst.
 For this document all rights are reserved.
 Printed documents are not subject to revision

Pos.-Nr. ItemNo	Menge Quantity	ME Unit	El.Kennz Ref.Des.	Benennung / Bezeichnung Designation	Z	Sachnummer Stock No.	Ersatzteil Subst.part	BA	VH
				ACHTUNG EGB/ATTENTION ESD *VARIANTENERKLAERUNG +EXPLANATION OF VARIANTS *VAR02=GRUNDVARIANTE +VAR02=BASIC MODEL *VAR03=UNREGISTERED +VAR03=UNREGISTERED					
10	0	S		ZS ERSATZTEILLISTE VORHANDEN SPARE PARTS LIST AVAIL 1406.6030.01 ST		0999.9684.00		M	O
980	1	S	A980	ED REVERSE POWER PROTECTION 13GHZ REVERSE POWER PROTECTION 13GHZ	Z	1412.6244.02	X	M	P
982	4	S		VS 6900/ISR M2.5 X 20 A2 COMBI SCREW 6900/ISR M2.5 X 20 A2		5302.0431.00	X	B	T
984	1	S	W983	DY KABEL W983 BB-OVP-ATT13 CABLE W983 BB-OVP-ATT13 nur bei / only if Option SMB-B112 1407.2109.01	Z	1406.9680.00	X	M	W
986	1	S	W195	DY KABEL W195 RF BOARD-AS13 CABLE W195 RF BOARD-AS13 nur bei / only if Option SMB-B112L 1407.2150.01	Z	1406.9222.00	X	M	B
988	1	S	W982	DW HF-KABEL W982 OVP-RF OUT RF CABLE W982 OVP-RF OUT	Z	1406.9480.00	X	M	P
990	1	S	W981_1	DW HF-KABEL W981_1 RFBO13-OVP RF CABLE W981_1 RFBO13-OVP nur bei / only if Option SMB-B112L 1407.2150.01	Z	1406.9497.00	X	M	P
992	1	S	W981	DW HF-KABEL W981 ATT13-OVP RF CABLE W981 ATT13-OVP nur bei / only if Option SMB-B112 1407.2109.01	Z	1406.9516.00	X	M	P
994	1	S		MZ LUFTABDECKBLECH KLEIN AIR COVER PANEL SMALL	Z	1406.9097.00	X	M	P
996	2	S		VS 965/ISR M2.5 X 4 A4 PA 965/ISR M2.5 X 4 A4 PA		1148.3271.00	X	B	T
1000	1	S		PI BEILAGE FUER UNREG. LIZENZEN SUPPLEMENT FOR UNREG. LICENSES VAR 03		1171.3322.00		M	W



ROHDE & SCHWARZ

Benennung/Designation

SMB-B30 ÜBERSpannungSSchutz
SMB-B30 OVERVOLTAGE PROTECTION

Sprach./Lang
de en

Ä.I. / C. /
05.00

Blatt/Sheet
1 of 1

Dokument Nr. / Document No.

1407.1160.01 ST

SMB-B30

Datum/
Date 2015-12-14

Abt. /
Dept. 1GAK

Name /
Name HG

Für diese Unterlage behalten wir uns alle Rechte vor.
 Ausgedruckte Dokumente unterliegen nicht dem Änderungsdienst.
 For this document all rights are reserved.
 Printed documents are not subject to revision

Pos.-Nr. ItemNo	Menge Quantity	ME Unit	El.Kennz Ref.Des.	Benennung / Bezeichnung Designation	Z	Sachnummer Stock No.	Ersatzteil Subst.part	BA	VH
				ACHTUNG EGB/ATTENTION ESD *VARIANTENERKLAERUNG +EXPLANATION OF VARIANTS *VAR02=GRUNDVARIANTE +VAR02=BASIC MODEL *VAR03=UNREGISTERED +VAR03=UNREGISTERED					
1020	1	S	A970	ED HIGH POWER 100KHZ-20G HIGH POWER 100KHZ-20G entfaellt in Kombination mit SMB-B25 not applicable in combination with SMB-B25	Z	1407.1290.02	X	M	P
1022	1	S	W921	DW HF-KABEL W921 RFBO20-FILTER20 RF CABLE W921 RFBO20-FILTER20	Z	1406.9945.00	X	M	W
1024	1	S	W192	DY KABEL W192 FILTER/HP-BB 26POL CABLE W192 FILTER/HP-BB 26POL	Z	1406.9768.00	X	M	O
1026	1	S	W220	DV KABEL W220 RFBO20 - FILTER/HP CABLE W220 RFBO20 - FILTER/HP	Z	1407.0170.00	X	M	O
1028	1	S	W928	DY KABEL W928 FILTER/HP-BB 12POL CABLE W928 FILTER/HP-BB 12POL	Z	1407.0193.00	X	M	P
1037	1	S	W980	DW HF-KABEL W980 FILTER-RFOUT RF CABLE W980 FILTER-RFOUT nur bei/ only if Option SMB-B120L 1407.2250.02	Z	1406.9897.00	X	M	W
1039	1	S	W922	DW HF-KABEL W922 FILTER-ATT44 RF CABLE W922 FILTER-ATT44 nur bei/ only if Option SMB-B120 1407.2209.02	Z	1406.9951.00	X	M	P
1100	1	S		PI BEILAGE FUER UNREG. LIZENZEN SUPPLEMENT FOR UNREG. LICENSES VAR 03		1171.3322.00		M	L



ROHDE & SCHWARZ

Benennung/Designation

SMB-B31 HOHE AUSGANGSLEISTUNG
SMB-B31 HIGH OUTPUT POWER

Sprach./Lang
de en

Ä.I. / C. /
06.00

Blatt/Sheet
1 of 1

SMB-B31

Datum/
Date 2014-02-24

Abt. /
Dept. MTEK

Name /
Name WU

Dokument Nr. / Document No.

1407.1260.01 ST

Für diese Unterlage behalten wir uns alle Rechte vor.
 Ausgedruckte Dokumente unterliegen nicht dem Änderungsdienst.
 For this document all rights are reserved.
 Printed documents are not subject to revision

Pos.-Nr. ItemNo	Menge Quantity	ME Unit	El.Kennz Ref.Des.	Benennung / Bezeichnung Designation	Z	Sachnummer Stock No.	Ersatzteil Subst.part	BA	VH
				ACHTUNG EGB/ATTENTION ESD *VARIANTENERKLAERUNG +EXPLANATION OF VARIANTS *VAR02=GRUNDVARIANTE +VAR02=BASIC MODEL					
1020	1	S	A970	ED HIGH POWER 100KHZ-20G HIGH POWER 100KHZ-20G entfaellt in Kombination mit SMB-B25 not applicable in combination with SMB-B25	Z	1407.1290.02	X	M	W
1022	1	S	W921	DW HF-KABEL W921 RFBO20-FILTER20 RF CABLE W921 RFBO20-FILTER20	Z	1406.9945.00	X	M	P
1024	1	S	W192	DY KABEL W192 FILTER/HP-BB 26POL CABLE W192 FILTER/HP-BB 26POL	Z	1406.9768.00	X	M	W
1026	1	S	W220	DV KABEL W220 RFBO20 - FILTER/HP CABLE W220 RFBO20 - FILTER/HP	Z	1407.0170.00		M	O
1027	1	S	W219	DV KABEL W219 CABLE FD40-RFBO20	Z	1406.9745.00	X	M	W
1028	1	S	W928	DY KABEL W928 FILTER/HP-BB 12POL CABLE W928 FILTER/HP-BB 12POL	Z	1407.0193.00	X	M	W
1030	1	S	W993	DW HF-KABEL W993 FILTER20-FD40P RF CABLE W993 FILTER20-FD40P	Z	1407.0158.00		M	P
1032	0	S		ZE DOUBLER FD40P DOUBLER FD40P bereits in Frequenzoption enthalten	Z	1315.0500.02		M	V
1034	1	S	W992_1	DW HF-KABEL W992_1 FD40P-ATT RF CABLE W992_1 FD40P-ATT nur bei/ only if Option SMB-B140 1407.2309.02	Z	1407.0164.00		M	P
1036	1	S	W992	DW HF-KABEL W992 FD40P-RFOUT RF CABLE W992 FD40P-RFOUT nur bei/ only if Option SMB-B140L 1407.2350.02	Z	1407.0141.00		M	W
1038	1	S	W991	DW HF-KABEL W991 RFBO20-FD40P LO20 RF CABLE W991 RFBO20-FD40P LO20	Z	1407.0135.00		M	P
1040	2	S		VS HVC/ISR M2.5 X 16 A2 COMBI SCREW HVC/ISR M2.5 X 16 A2		0048.8218.00		B	B



ROHDE & SCHWARZ

Benennung/Designation
SMB-B32 HOHE AUSGANGSLEISTUNG
SMB-B32 HIGH OUTPUT POWER

Sprach./Lang de en Ä.I. / C.I 07.00 Blatt/Sheet 1 of 1

Dokument Nr. / Document No.
1407.1360.01 ST

SMB-B32

Datum/Date 2015-07-21 Abt./Dept. 1GAK Name/Name HG

Für diese Unterlage behalten wir uns alle Rechte vor.
 Ausgedruckte Dokumente unterliegen nicht dem Änderungsdienst.
 For this document all rights are reserved.
 Printed documents are not subject to revision

Pos.-Nr. ItemNo	Menge Quantity	ME Unit	El.Kennz Ref.Des.	Benennung / Bezeichnung Designation	Z	Sachnummer Stock No.	Ersatzteil Subst.part	BA	VH
				ACHTUNG EGB/ATTENTION ESD *VARIANTENERKLAERUNG *EXPLANATION OF MODELS VAR02=GRUNDVARIANTE MOD02=BASIC MODEL					
100	1	S		ZE GRUNDEINHEIT SMB MICROWELLE BASIC UNIT SMB MICROWAVE	Z	1406.9045.02		M	
245	1	S		FJ HF-ABSCHLUSSKAPPE SMA PROTECTION CAP auf A200-X208/X209/X211/X216		1066.2095.00		B	B
450	1	S		ZN ADAPTERHALTEWINKEL HOLDER f. Ausgangsbuchse	Z	1406.9168.00		M	P
460	6	S		VS 965/ISR-M2.5X5-A4-PA 965/ISR-M2.5X5-A4-PA		1148.2752.00	X	B	T
500	1	S		KB FRONTHAUBE BEDR. 12 FRONT COVER 12	Z	1406.9068.00		M	P
505	.25	S		MP KLEBEFOLIE 80X20 GRAU COVER		1110.2403.00		B	O
950	1	S	A950	ED ASATT 13GHZ ASATT 13GHZ	Z	1412.5360.02	X	M	P
952	4	S		VS 6900/ISR-M2.5X25-A2 COMBI SCREW 6900/ISR-M2.5X25-A2		3584.5502.00	X	B	O
954	1	S	W195	DY KABEL W195 RF BOARD-AS13 CABLE W195 RF BOARD-AS13	Z	1406.9222.00	X	M	P
956	1	S	W220	DW HF-KABEL W220 RFBO13-AS13 RF CABLE W220 RFBO13-AS13	Z	1406.9268.00	X	M	P
958	1	S	W221	DW HF-KABEL W221 AS13-RF OUT RF CABLE W221 AS13-RF OUT	Z	1406.9274.00	X	M	P
959	1	S		HS FIRMWARE SMB -B112/ B112L FIRMWARE SMB -B112/ B112L	Z	1407.0429.00		M	
960	1	S		FJ TESTPORT GEH.ADAPTER ADAPTOR		1021.0493.00		B	O
962	1	S		FJ TESTPORT-ADAPT.F.PC3.5 ADAPTER RPC-3.5 FEMALE		1021.0512.00		B	O
963	1	S		ZN HALTEBLECH ASATT 13GHZ HOLDING PLATE ASATT 13GHZ nicht bei altem Chassis (geänderter Durchbruch) not with old chassis (other opening)	Z	1407.0241.00		M	O
964	2	S		VS 6900/ISR-M2.5X5-A2 COMBI SCREW 6900/ISR-M2.5X5-A2 nicht bei altem Chassis (geänderter Durchbruch) not with old chassis (other opening)		0041.1630.00		B	T
994	1	S		MZ LUFTABDECKBLECH KLEIN AIR COVER PANEL SMALL	Z	1406.9097.00	X	M	P
996	2	S		VS 965/ISR-M2.5X5-A4-PA 965/ISR-M2.5X5-A4-PA		1148.2752.00	X	B	T



ROHDE & SCHWARZ

Benennung/Designation

SMB-B112 100 KHZ BIS 12.75 GHZ
SMB-B112 100 KHZ TO 12.75 GHZ

Sprach./Lang
de en

Ä.I. / C.I.
11.00

Blatt/Sheet
1 of 1

Dokument Nr. / Document No.

1407.2109.01 ST

SMB-B112

Datum/
Date 2012-11-06

Abt. /
Dept. 1GPK

Name /
Name MS

Für diese Unterlage behalten wir uns alle Rechte vor.
 Ausgedruckte Dokumente unterliegen nicht dem Änderungsdienst.
 For this document all rights are reserved.
 Printed documents are not subject to revision

Pos.-Nr. ItemNo	Menge Quantity	ME Unit	El.Kennz Ref.Des.	Benennung / Bezeichnung Designation	Z	Sachnummer Stock No.	Ersatzteil Subst.part	BA	VH
				ACHTUNG EGB/ATTENTION ESD *VARIANTENERKLAERUNG *EXPLANATION OF MODELS VAR02=GRUNDVARIANTE MOD02=BASIC MODEL					
100	1	S		ZE GRUNDEINHEIT SMB MICROWELLE BASIC UNIT SMB MICROWAVE	Z	1406.9045.02		M	
245	1	S		FJ HF-ABSCHLUSSKAPPE SMA PROTECTION CAP auf A200-X208/X209/X211/X216		1066.2095.00		B	B
450	1	S		ZN ADAPTERHALTEWINKEL HOLDER f. Ausgangsbuchse	Z	1406.9168.00		M	P
460	6	S		VS 965/ISR-M2.5X5-A4-PA SCREW		1148.2752.00		B	T
500	1	S		KB FRONTHAUBE BEDR. 12 FRONT COVER 12	Z	1406.9068.00		M	W
650	1	S	W212	DW HF-KABEL W212 (U) RF CABLE W212 (U)	Z	1406.9322.00		M	P
843	1	S		MZ LUFTABDECKBLECH GROSS AIR COVER PANEL BIG	Z	1406.9597.00		M	O
844	2	S		VS 965/ISR-M2.5X5-A4-PA SCREW		1148.2752.00		B	T
959	1	S		HS FIRMWARE SMB -B112/ B112L FIRMWARE SMB -B112/ B112L	Z	1407.0429.00		M	
960	1	S		FJ TESTPORT GEH.ADAPTER ADAPTOR		1021.0493.00		B	O
962	1	S		FJ TESTPORT-ADAPT.F.PC3.5 ADAPTER RPC-3.5 FEMALE		1021.0512.00		B	O



ROHDE & SCHWARZ

Benennung/Designation

SMB-B112L 100 KHZ BIS 12.75 GHZ
SMB-B112L 100 KHZ TO 12.75 GHZ

Sprach./Lang
de en

Ä.I. / C.I
09.00

Blatt/Sheet
1 of 1

Dokument Nr. / Document No.

1407.2150.01 ST

SMB-B112L

Datum/
Date 2011-12-07

Abt. /
Dept. 1GPK

Name /
Name MK

Für diese Unterlage behalten wir uns alle Rechte vor.
 Ausgedruckte Dokumente unterliegen nicht dem Änderungsdienst.
 For this document all rights are reserved.
 Printed documents are not subject to revision

Pos.-Nr. ItemNo	Menge Quantity	ME Unit	El.Kennz Ref.Des.	Benennung / Bezeichnung Designation	Z	Sachnummer Stock No.	Ersatzteil Subst.part	BA	VH
				ACHTUNG EGB/ATTENTION ESD *VARIANTENERKLAERUNG *EXPLANATION OF MODELS VAR02=GRUNDVARIANTE MOD02=BASIC MODEL					
100	1	S		ZE GRUNDEINHEIT SMB MICROWELLE BASIC UNIT SMB MICROWAVE	Z	1406.9045.02		M	
245	1	S		FJ HF-ABSCHLUSSKAPPE SMA PROTECTION CAP		1066.2095.00		B	B
452	1	S		FJ HF-D.FLANSCH 28X28X0.8		1104.1644.00		B	B
454	1	S		ZN ADAPTERHALTEWINKEL HOLDER	Z	1406.9168.00		M	P
456	1	S	X1A	FJ TESTPORT GEH.ADAPTER ADAPTOR		1021.0493.00		B	O
458	1	S	X1B	FJ TESTPORT-ADAPT.F.PC3.5 ADAPTER RPC-3.5 FEMALE		1021.0512.00		B	O
460	4	S		VS 965/ISR-M2.5X5-A4-PA SCREW		1148.2752.00		B	T
465	2	S		VS 965/ISR-M2.5X5-A4-PA SCREW		1148.2752.00		B	T
501	1	S		KB FRONTHAUBE BEDR. 20 FRONT COVER 20	Z	1406.8003.00		M	O
611	1	S		MZ LUFTBREMSE AIR FLAP entfaellt in Kombination mit SMB- B25und/oder SMB-B31 not applicable in combination with SMB-B25 and/or SMB-B31		1406.9539.00		M	P
612	1	S		ZN HALTER RF BOARD 20 HOLDER RF BOARD 20	Z	1406.9600.00		M	P
613	4	S		VS 6900/ISR-M2.5X20-A2 SCREW		5302.0431.00		B	T
614	1	S	A220	ED RF BOARD 20 GHZ RF BOARD 20 GHZ	Z	1406.7407.02	X	M	O
615	4	S		VS 6900/ISR-M2.5X20-A2 SCREW		5302.0431.00		B	T
616	1	S	A960	ZE EICHLLEITUNG 115DB 5DB STEP ATTENUATOR 115DB 5DB	Z	1170.0094.02	X	M	W
617	1	S		MZ BODENPLATTE EICHLLEITUNG ATTENUATOR PANEL	Z	1406.9245.00		M	P
618	4	S		VS 7985/ISR-M2.5X5-A4-PA 7985/ISR-M2.5X5-A4-PA		1148.2617.00		B	T
619	2	S		VS 6900/ISR-M2.5X5-A2 COMBINATION SCREWS		0041.1630.00		B	T
620	1	S	W103	DY KABEL W103 BB-RFBO20 50POL CABLE W103 BB-RFBO20 50POL	Z	1407.0112.00		M	P
621	1	S	W216_2	DW HF-KABEL W216_2 RFBO13-RFBO20 RF CABLE W216_2 RFBO13-RFBO20	Z	1406.9380.00		M	P
622	1	S	W03	DW HF-KABEL W03 ATT44-OUT RF CABLE W03 ATT44-OUT	Z	1406.9474.00		M	P
623	1	S	W212_2	DW HF-KABEL W212_2 RFBO13-RFBO20	Z	1406.9397.00		M	P



ROHDE & SCHWARZ

Benennung/Designation

SMB-B120 100 KHZ BIS 20 GHZ
SMB-B120 100 KHZ TO 20 GHZ

Sprach./Lang

de en

Ä.I. / C.I

10.00

Blatt/Sheet

1 of 2

Dokument Nr. / Document No.

1407.2209.01 ST

SMB-B120

Datum/
Date

2011-12-16

Abt. /
Dept.

1GPK

Name /
Name

MS

Für diese Unterlage behalten wir uns alle Rechte vor.
 Ausgedruckte Dokumente unterliegen nicht dem Änderungsdienst.
 For this document all rights are reserved.
 Printed documents are not subject to revision

Pos.-Nr. ItemNo	Menge Quantity	ME Unit	El.Kennz Ref.Des.	Benennung / Bezeichnung Designation	Z	Sachnummer Stock No.	Ersatzteil Subst.part	BA	VH
624	1	S	W211_3	RF CABLE W212_2 RFBO13-RFBO20 DW HF-KABEL W211_3 RFBO20-ATT44 RF CABLE W211_3 RFBO20-ATT44 entfaellt in Kombination mit SMB-B25 und/oder SMB-B31 not applicable in combination with SMB-B25 and/or SMB-B31	Z	1406.9297.00		M	P
625	1	S	W217	DV KABEL W217 CABLE RFBO20-RFBO13	Z	1406.9722.00		M	P
626	1	S	W218	DV KABEL W218 CABLE RFBO13-RFBO20	Z	1406.9739.00		M	P
627	1	S		VS 6900/ISR-M2.5X5-A2 COMBINATION SCREWS		0041.1630.00		B	T
629	1	S		MZ NIEDERHALTER KABEL DOWNHOLDER CABLE		1407.0187.00		M	O
640	1	S		MZ LUFTABDECKBLECH L-FOERMIG AIR COVER PANEL L-SHAPED	Z	1407.0064.00		M	P
641	2	S		VS 965/ISR-M2.5X5-A4-PA SCREW		1148.2752.00		B	T
953	1	S		HS FIRMW. SMB -B120/ B120L/B140/B140L FIRMW. SMB -B120/ B120L/B140/B140L	Z	1407.0435.00		M	
954	1	S	W195	DY KABEL W195 RF BOARD-AS13 CABLE W195 RF BOARD-AS13	Z	1406.9222.00		M	P

 ROHDE & SCHWARZ	Benennung/Designation SMB-B120 100 KHZ BIS 20 GHZ SMB-B120 100 KHZ TO 20 GHZ			Sprach./Lang de en	Ä.I. / C./ 10.00	Blatt/Sheet 2 of 2
	SMB-B120	Datum/ Date	2011-12-16	Abt. / Dept.	1GPK	Name / Name
Dokument Nr. / Document No.						1407.2209.01 ST

Für diese Unterlage behalten wir uns alle Rechte vor.
 Ausgedruckte Dokumente unterliegen nicht dem Änderungsdienst.
 For this document all rights are reserved.
 Printed documents are not subject to revision

Pos.-Nr. ItemNo	Menge Quantity	ME Unit	El.Kennz Ref.Des.	Benennung / Bezeichnung Designation	Z	Sachnummer Stock No.	Ersatzteil Subst.part	BA	VH
				ACHTUNG EGB/ATTENTION ESD *VARIANTENERKLAERUNG *EXPLANATION OF MODELS VAR02=GRUNDVARIANTE MOD02=BASIC MODEL					
100	1	S		ZE GRUNDEINHEIT SMB MICROWELLE BASIC UNIT SMB MICROWAVE	Z	1406.9045.02		M	
245	1	S		FJ HF-ABSCHLUSSKAPPE SMA PROTECTION CAP		1066.2095.00		B	B
452	1	S		FJ HF-D.FLANSCH 28X28X0.8		1104.1644.00		B	B
454	1	S		ZN ADAPTERHALTEWINKEL HOLDER	Z	1406.9168.00		M	P
456	1	S	X1A	FJ TESTPORT GEH.ADAPTER ADAPTOR		1021.0493.00		B	O
458	1	S	X1B	FJ TESTPORT-ADAPT.F.PC3.5 ADAPTER RPC-3.5 FEMALE		1021.0512.00		B	O
460	4	S		VS 965/ISR-M2.5X5-A4-PA SCREW		1148.2752.00		B	T
465	2	S		VS 965/ISR-M2.5X5-A4-PA SCREW		1148.2752.00		B	T
501	1	S		KB FRONTHAUBE BEDR. 20 FRONT COVER 20	Z	1406.8003.00		M	O
611	1	S		MZ LUFTBREMSE AIR FLAP entfaellt in Kombination mit SMB- B25und/oder SMB-B31 not applicable in combination with SMB-B25 and/or SMB-B31		1406.9539.00		M	P
612	1	S		ZN HALTER RF BOARD 20 HOLDER RF BOARD 20	Z	1406.9600.00		M	P
613	4	S		VS 6900/ISR-M2.5X20-A2 SCREW		5302.0431.00		B	T
614	1	S	A220	ED RF BOARD 20 GHZ RF BOARD 20 GHZ	Z	1406.7407.02	X	M	O
615	4	S		VS 6900/ISR-M2.5X20-A2 SCREW		5302.0431.00		B	T
620	1	S	W103	DY KABEL W103 BB-RFBO20 50POL CABLE W103 BB-RFBO20 50POL	Z	1407.0112.00		M	P
621	1	S	W216_2	DW HF-KABEL W216_2 RFBO13-RFBO20 RF CABLE W216_2 RFBO13-RFBO20	Z	1406.9380.00		M	P
623	1	S	W212_2	DW HF-KABEL W212_2 RFBO13-RFBO20 RF CABLE W212_2 RFBO13-RFBO20	Z	1406.9397.00		M	P
625	1	S	W217	DV KABEL W217 CABLE RFBO20-RFBO13	Z	1406.9722.00		M	P
626	1	S	W218	DV KABEL W218 CABLE RFBO13-RFBO20	Z	1406.9739.00		M	P
627	1	S		VS 6900/ISR-M2.5X5-A2 COMBINATION SCREWS		0041.1630.00		B	T
628	1	S	W211_2	DW HF-KABEL W211_2 RFBO20-OUT RF CABLE W211_2 RFBO20-OUT entfaellt in Kombination mit SMB- B25und/oder SMB-B31	Z	1406.9374.00		M	P



ROHDE & SCHWARZ

Benennung/Designation

SMB-B120L 100 KHZ BIS 20 GHZ
SMB-B120L 100 KHZ TO 20 GHZ

Sprach./Lang
de en

Ä.I. / C.I
09.00

Blatt/Sheet
1 of 2

Dokument Nr. / Document No.

1407.2250.01 ST

SMB-B120L

Datum/
Date

2011-12-16

Abt. /
Dept.

1GPK

Name /
Name

MS

Für diese Unterlage behalten wir uns alle Rechte vor.
 Ausgedruckte Dokumente unterliegen nicht dem Änderungsdienst.
 For this document all rights are reserved.
 Printed documents are not subject to revision

Pos.-Nr. <i>ItemNo</i>	Menge <i>Quantity</i>	ME <i>Unit</i>	El.Kennz <i>Ref.Des.</i>	Benennung / Bezeichnung <i>Designation</i>	Z	Sachnummer <i>Stock No.</i>	Ersatzteil <i>Subst.part</i>	BA	VH
629	1	S		not applicable in combination with SMB-B25 and/or SMB-B31 MZ NIEDERHALTER KABEL DOWNHOLDER CABLE		1407.0187.00		M	O
640	1	S		MZ LUFTABDECKBLECH L-FOERMIG AIR COVER PANEL L-SHAPED	Z	1407.0064.00		M	P
641	2	S		VS 965/ISR-M2.5X5-A4-PA SCREW		1148.2752.00		B	T
953	1	S		HS FIRMW. SMB -B120/ B120L/B140/B140L FIRMW. SMB -B120/ B120L/B140/B140L	Z	1407.0435.00		M	

 ROHDE & SCHWARZ	Benennung/ <i>Designation</i>			Sprach./Lang de en	Ä.I. / C./ 09.00	Blatt/Sheet 2 of 2
	SMB-B120L 100 KHZ BIS 20 GHZ SMB-B120L 100 KHZ TO 20 GHZ			Dokument Nr. / Document No.		
SMB-B120L	Datum/ Date	2011-12-16	Abt. / Dept.	1GPK	Name / Name	MS
						1407.2250.01 ST

Für diese Unterlage behalten wir uns alle Rechte vor.
 Ausgedruckte Dokumente unterliegen nicht dem Änderungsdienst.
 For this document all rights are reserved.
 Printed documents are not subject to revision

Pos.-Nr. ItemNo	Menge Quantity	ME Unit	El.Kennz Ref.Des.	Benennung / Bezeichnung Designation	Z	Sachnummer Stock No.	Ersatzteil Subst.part	BA	VH
				ACHTUNG EGB/ATTENTION ESD *VARIANTENERKLAERUNG +EXPLANATION OF VARIANTS *VAR02=GRUNDVARIANTE +VAR02=BASIC MODEL					
100	1	S		ZE GRUNDEINHEIT SMB MICROWELLE BASIC UNIT SMB MICROWAVE	Z	1406.9045.02		M	P
452	1	S		FJ HF-D.FLANSCH 28X28X0.8 ACCESSORIES FOR CONNECTORS		1104.1644.00		B	B
453	1	S	X1A	FJ GEHAEUSE-ADAPTER TESTPORT-ADAPTOR		1036.4702.00		B	O
454	1	S		ZN ADAPTERHALTEWINKEL HOLDER	Z	1406.9168.00		M	P
455	1	S	X1B	FJ TESTPORT-ADAPTERK-BU. TESTPORT-ADAPTOR		1036.4790.00		B	O
460	4	S		VS 965/ISR M2.5 X 5 A4 PA 965/ISR M2.5 X 5 A4 PA		1148.2752.00		B	T
465	2	S		VS 965/ISR M2.5 X 5 A4 PA 965/ISR M2.5 X 5 A4 PA		1148.2752.00		B	T
502	1	S		KB FRONTHAUBE BEDR. 40 FRONT COVER 40	Z	1406.8010.00		M	P
611	1	S		MZ LUFTBREMSE AIR FLAP entfaellt in Kombination mit SMB-B32, SMB B31 und/oder SMB-B26 not applicable in combination with SMB-B32, SMB-B31 and/or SMB-B26		1406.9539.00		M	P
612	1	S		ZN HALTER RF BOARD 20 HOLDER RF BOARD 20	Z	1406.9600.00		M	P
613	4	S		VS 6900/ISR M2.5 X 20 A2 COMBI SCREW 6900/ISR M2.5 X 20 A2		5302.0431.00		B	T
614	1	S	A220	ED RF BOARD 20 GHZ RF BOARD 20 GHZ	Z	1406.7407.02	X	M	P
615	4	S		VS 6900/ISR M2.5 X 20 A2 COMBI SCREW 6900/ISR M2.5 X 20 A2		5302.0431.00		B	T
616	1	S	A960	ZE EICHLEITUNG 115DB 5DB STEP ATTENUATOR 115DB 5DB	Z	1170.0113.02	X	M	O
617	1	S		MZ BODENPLATTE EICHLEITUNG ATTENUATOR PANEL	Z	1406.9245.00		M	P
618	4	S		VS 7985/ISR M2.5 X 5 A4 PA 7985/ISR M2.5 X 5 A4 PA		1148.2617.00		B	T
619	2	S		VS 6900/ISR M2.5 X 5 A2 COMBI SCREW 6900/ISR M2.5 X 5 A2		0041.1630.00		B	T
620	1	S	W103	DY KABEL W103 BB-RFBO20 50POL CABLE W103 BB-RFBO20 50POL	Z	1407.0112.00		M	B
621	1	S	W216_2	DW HF-KABEL W216_2 RFBO13-RFBO20 RF CABLE W216_2 RFBO13-RFBO20	Z	1406.9380.00		M	P
623	1	S	W212_2	DW HF-KABEL W212_2 RFBO13-RFBO20 RF CABLE W212_2 RFBO13-RFBO20	Z	1406.9397.00		M	P
625	1	S	W217	DV KABEL W217 CABLE RFBO20-RFBO13	Z	1406.9722.00		M	W



ROHDE & SCHWARZ

Benennung/Designation

SMB-B140 100 KHZ BIS 40 GHZ
SMB-B140 100 KHZ TO 40 GHZ

Sprach./Lang

de en

Ä.I. / C.I

13.00

Blatt/Sheet

1 of 2

Dokument Nr. / Document No.

1407.2309.01 ST

SMB-B140

Datum/
Date

2015-07-23

Abt. /
Dept.

1GAK

Name /
Name

HG

Für diese Unterlage behalten wir uns alle Rechte vor.
 Ausgedruckte Dokumente unterliegen nicht dem Änderungsdienst.
 For this document all rights are reserved.
 Printed documents are not subject to revision

Pos.-Nr. ItemNo	Menge Quantity	ME Unit	El.Kennz Ref.Des.	Benennung / Bezeichnung Designation	Z	Sachnummer Stock No.	Ersatzteil Subst.part	BA	VH
626	1	S	W218	DV KABEL W218 CABLE RFBO13-RFBO20	Z	1406.9739.00		M	W
627	1	S		VS 6900/ISR M2.5 X 5 A2 COMBI SCREW 6900/ISR M2.5 X 5 A2		0041.1630.00		B	T
629	1	S		MZ NIEDERHALTER KABEL DOWNHOLDER CABLE		1407.0187.00		M	P
640	1	S		MZ LUFTABDECKBLECH L-FOERMIG AIR COVER PANEL L-SHAPED	Z	1407.0064.00		M	P
641	2	S		VS 965/ISR M2.5 X 5 A4 PA 965/ISR M2.5 X 5 A4 PA		1148.2752.00		B	T
904	1	S	A990	ZE DOUBLER FD40P DOUBLER FD40P nur in Kombination mit SMB-B32 und/oder SMB-B26 only in combination with SMB-B32 and/or SMB-B26	Z	1315.0500.02		M	V
905	1	S	A820	ZE DOUBLER FD40 entfaellt in Kombination mit SMB-B32 und/oder SMB-B26 not applicable in combination with SMB-B32 and/or SMB-B26	Z	1312.1006.02	X	M	
906	1	S		ZN TRAEGER HOLDER	Z	1406.9574.00		M	P
908	4	S		VS 6900/ISR M2.5 X 5 A2 COMBI SCREW 6900/ISR M2.5 X 5 A2		0041.1630.00		B	T
909	4	S		VS HVC/ISR M2.5 X 12 A2 COMBI SCREW HVC/ISR M2.5 X 12 A2		1096.5205.00		B	B
910	1	S	W211	DW HF-KABEL W211 RFBO20-FD40 RF CABLE W211 RFBO20-FD40 entfaellt in Kombination mit SMB-B32 und/oder SMB-B26 not applicable in combination with SMB-B32 and/or SMB-B26	Z	1406.9345.00		M	P
912	1	S	W212_4	DW HF-KABEL W212_4 FD40-ATT44 RF CABLE W212_4 FD40-ATT44 entfaellt in Kombination mit SMB-B32 und/oder SMB-B26 not applicable in combination with SMB-B32 and/or SMB-B26	Z	1406.9500.00		M	P
914	1	S	W02	DW HF-KABEL W02 ATT44-OUT RF CABLE W02 ATT44-OUT	Z	1406.9280.00		M	O
916	1	S	W219	DV KABEL W219 CABLE FD40-RFBO20	Z	1406.9745.00		M	W
918	1	S	W223	DY KABEL W223 BB-FD40 50POL CABLE W223 BB-FD40 50POL	Z	1407.0129.00		M	W
920	1	S	W215	DW HF-KABEL W215 RFBO20-FD40 RF CABLE W215 RFBO20-FD40 entfaellt in Kombination mit SMB-B32 und/oder SMB-B26 not applicable in combination with SMB-B32 and/or SMB-B26	Z	1406.9351.00		M	P
953	1	S		HS FIRMW. SMB -B120/ B120L/B140/B140L FIRMW. SMB -B120/ B120L/B140/B140L	Z	1407.0435.00		M	B
954	1	S	W195	DY KABEL W195 RF BOARD-AS13 CABLE W195 RF BOARD-AS13	Z	1406.9222.00		M	B



ROHDE & SCHWARZ

Benennung/Designation

SMB-B140 100 KHZ BIS 40 GHZ
SMB-B140 100 KHZ TO 40 GHZ

Sprach./Lang
de en

Ä.I. / C.I
13.00

Blatt/Sheet
2 of 2

Dokument Nr. / Document No.

1407.2309.01 ST

SMB-B140

Datum/
Date 2015-07-23

Abt. /
Dept. 1GAK

Name /
Name HG

Für diese Unterlage behalten wir uns alle Rechte vor.
 Ausgedruckte Dokumente unterliegen nicht dem Änderungsdienst.
 For this document all rights are reserved.
 Printed documents are not subject to revision

Pos.-Nr. ItemNo	Menge Quantity	ME Unit	El.Kennz Ref.Des.	Benennung / Bezeichnung Designation	Z	Sachnummer Stock No.	Ersatzteil Subst.part	BA	VH
				ACHTUNG EGB/ATTENTION ESD *VARIANTENERKLAERUNG +EXPLANATION OF VARIANTS *VAR02=GRUNDVARIANTE +VAR02=BASIC MODEL					
100	1	S		ZE GRUNDEINHEIT SMB MICROWELLE BASIC UNIT SMB MICROWAVE	Z	1406.9045.02		M	P
452	1	S		FJ HF-D.FLANSCH 28X28X0.8 ACCESSORIES FOR CONNECTORS		1104.1644.00		B	B
453	1	S	X1A	FJ GEHAEUSE-ADAPTER TESTPORT-ADAPTOR		1036.4702.00		B	O
454	1	S		ZN ADAPTERHALTEWINKEL HOLDER	Z	1406.9168.00		M	P
455	1	S	X1B	FJ TESTPORT-ADAPTERK-BU. TESTPORT-ADAPTOR		1036.4790.00		B	O
460	4	S		VS 965/ISR M2.5 X 5 A4 PA 965/ISR M2.5 X 5 A4 PA		1148.2752.00		B	T
465	2	S		VS 965/ISR M2.5 X 5 A4 PA 965/ISR M2.5 X 5 A4 PA		1148.2752.00		B	T
500	1	S		KB FRONTHAUBE BEDR. 40 FRONT COVER 40	Z	1406.8010.00		M	P
611	1	S		MZ LUFTBREMSE AIR FLAP entfaellt in Kombination mit SMB-B32, SMB- B31 und/oder SMB-B26 not applicable in combination with SMB-B32, SMB-B31 and/or SMB-B26		1406.9539.00		M	P
612	1	S		ZN HALTER RF BOARD 20 HOLDER RF BOARD 20	Z	1406.9600.00		M	P
613	4	S		VS 6900/ISR M2.5 X 20 A2 COMBI SCREW 6900/ISR M2.5 X 20 A2		5302.0431.00		B	T
614	1	S	A220	ED RF BOARD 20 GHZ RF BOARD 20 GHZ	Z	1406.7407.02	X	M	P
615	4	S		VS 6900/ISR M2.5 X 20 A2 COMBI SCREW 6900/ISR M2.5 X 20 A2		5302.0431.00		B	T
620	1	S	W103	DY KABEL W103 BB-RFBO20 50POL CABLE W103 BB-RFBO20 50POL	Z	1407.0112.00		M	B
621	1	S	W216_2	DW HF-KABEL W216_2 RFBO13-RFBO20 RF CABLE W216_2 RFBO13-RFBO20	Z	1406.9380.00		M	P
623	1	S	W212_2	DW HF-KABEL W212_2 RFBO13-RFBO20 RF CABLE W212_2 RFBO13-RFBO20	Z	1406.9397.00		M	P
625	1	S	W217	DV KABEL W217 CABLE RFBO20-RFBO13	Z	1406.9722.00		M	W
626	1	S	W218	DV KABEL W218 CABLE RFBO13-RFBO20	Z	1406.9739.00		M	W
627	1	S		VS 6900/ISR M2.5 X 5 A2 COMBI SCREW 6900/ISR M2.5 X 5 A2		0041.1630.00		B	T
629	1	S		MZ NIEDERHALTER KABEL DOWNHOLDER CABLE		1407.0187.00		M	P
640	1	S		MZ LUFTABDECKBLECH L-FOERMIG AIR COVER PANEL L-SHAPED	Z	1407.0064.00		M	P



ROHDE & SCHWARZ

Benennung/Designation

SMB-B140L 100 KHZ BIS 40 GHZ
SMB-B140L 100 KHZ TO 40 GHZ

Sprach./Lang
de en

Ä.I. / C.I.
12.00

Blatt/Sheet
1 of 2

Dokument Nr. / Document No.

1407.2350.01 ST

SMB-B140L

Datum/
Date 2015-07-23

Abt. /
Dept. 1GAK

Name /
Name HG

Für diese Unterlage behalten wir uns alle Rechte vor.
 Ausgedruckte Dokumente unterliegen nicht dem Änderungsdienst.
 For this document all rights are reserved.
 Printed documents are not subject to revision

Pos.-Nr. ItemNo	Menge Quantity	ME Unit	El.Kennz Ref.Des.	Benennung / Bezeichnung Designation	Z	Sachnummer Stock No.	Ersatzteil Subst.part	BA	VH
641	2	S		VS 965/ISR M2.5 X 5 A4 PA 965/ISR M2.5 X 5 A4 PA		1148.2752.00		B	T
904	1	S	A990	ZE DOUBLER FD40P DOUBLER FD40P nur in Kombination mit SMB-B32 und/oder SMB-B26 only in combination with SMB-B32 and/or SMB-B26	Z	1315.0500.02	X	M	V
905	1	S	A820	ZE DOUBLER FD40 entfaellt in Kombination mit SMB-B32 und/oder SMB-B26 not applicable in combination with SMB-B32 and/or SMB-B26	Z	1312.1006.02	X	M	
906	1	S		ZN TRAEGER HOLDER	Z	1406.9574.00		M	P
908	4	S		VS 6900/ISR M2.5 X 5 A2 COMBI SCREW 6900/ISR M2.5 X 5 A2		0041.1630.00		B	T
909	4	S		VS HVC/ISR M2.5 X 12 A2 COMBI SCREW HVC/ISR M2.5 X 12 A2		1096.5205.00		B	B
910	1	S	W211	DW HF-KABEL W211 RFBO20-FD40 RF CABLE W211 RFBO20-FD40 entfaellt in Kombination mit SMB-B32 und/oder SMB-B26 not applicable in combination with SMB-B32 and/or SMB-B26	Z	1406.9345.00		M	P
915	1	S	W212_3	DW HF-KABEL W212_3 FD40-OUT RF CABLE W212_3 FD40-OUT entfaellt in Kombination mit SMB-B32 und/oder SMB-B26 not applicable in combination with SMB-B32 and/or SMB-B26	Z	1406.9368.00		M	P
916	1	S	W219	DV KABEL W219 CABLE FD40-RFBO20	Z	1406.9745.00		M	W
918	1	S	W223	DY KABEL W223 BB-FD40 50POL CABLE W223 BB-FD40 50POL	Z	1407.0129.00		M	W
920	1	S	W215	DW HF-KABEL W215 RFBO20-FD40 RF CABLE W215 RFBO20-FD40 entfaellt in Kombination mit SMB-B32 und/oder SMB-B26 not applicable in combination with SMB-B32 and/or SMB-B26	Z	1406.9351.00		M	P
953	1	S		HS FIRMW. SMB -B120/ B120L/B140/B140L FIRMW. SMB -B120/ B120L/B140/B140L	Z	1407.0435.00		M	B



ROHDE & SCHWARZ

Benennung/Designation

SMB-B140L 100 KHZ BIS 40 GHZ
SMB-B140L 100 KHZ TO 40 GHZ

Sprach./Lang
de en

Ä.I. / C. /
12.00

Blatt/Sheet
2 of 2

Dokument Nr. / Document No.

1407.2350.01 ST

SMB-B140L

Datum/
Date 2015-07-23

Abt. /
Dept. 1GAK

Name /
Name HG

Mechanical Drawings

Pos. 510 nicht dargestellt (Tubus)
not shown (Tube)

I

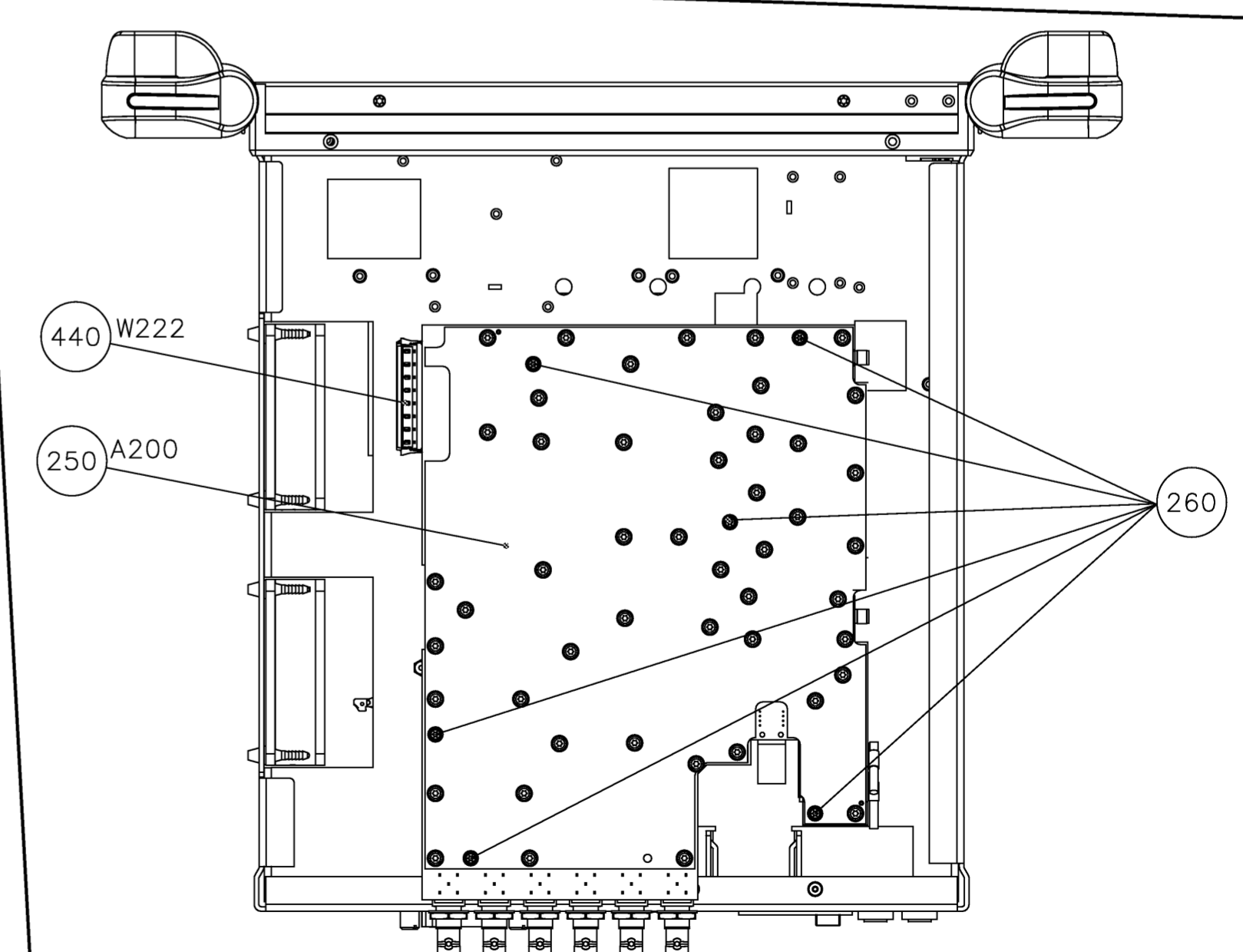
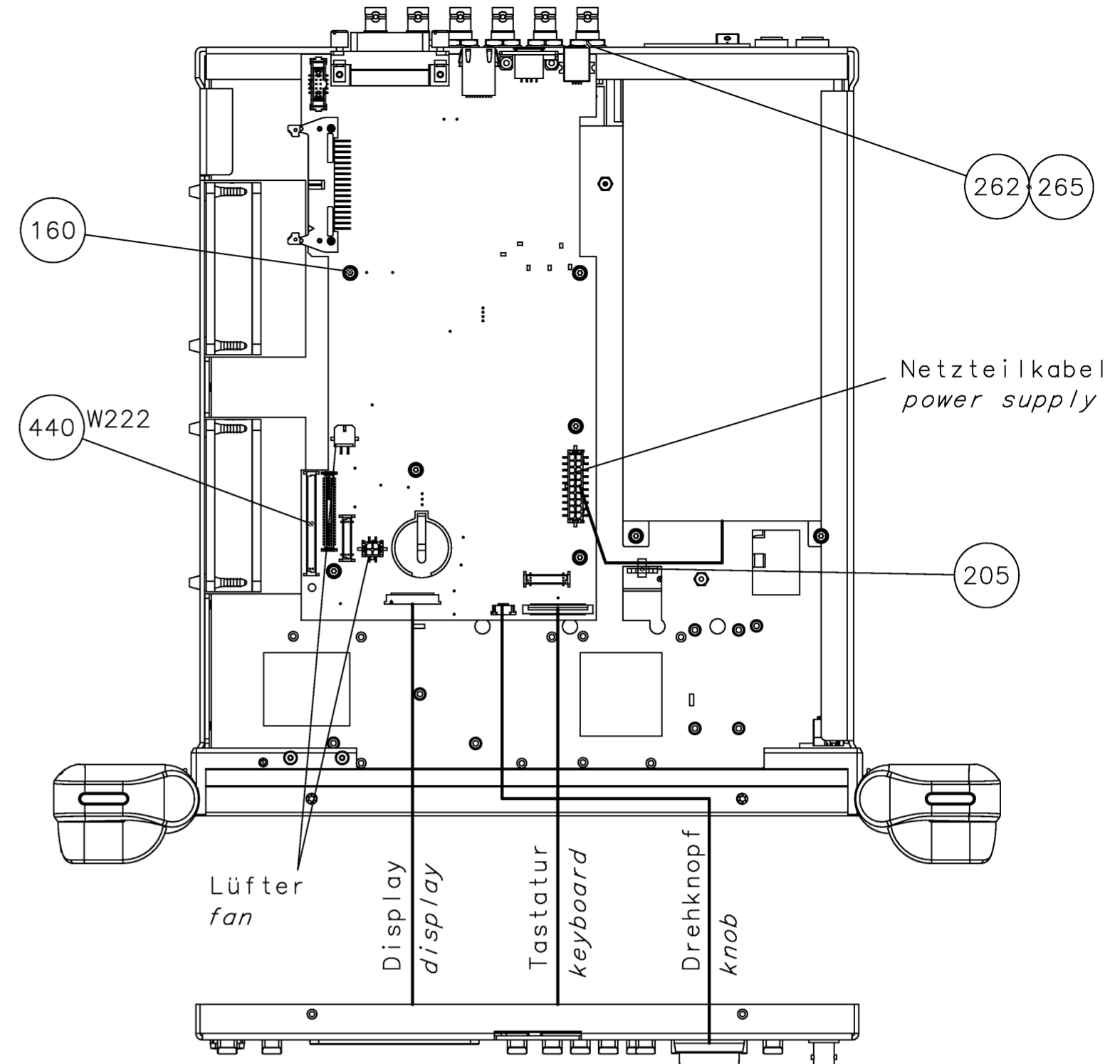
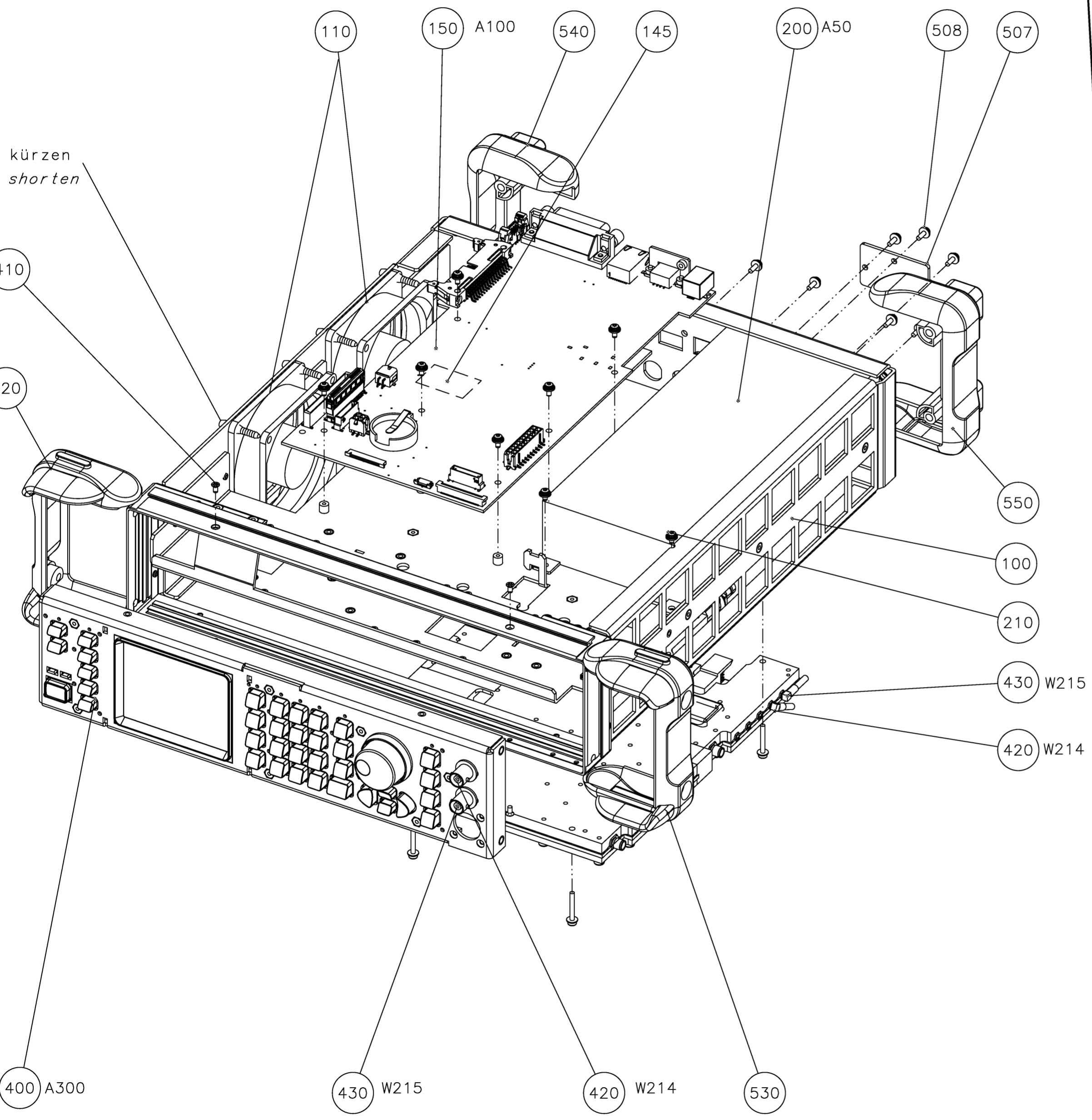

Für dieses Dokument behalten wir uns alle Rechte vor
For this document all rights are reserved

Projektions-
methode
Projection
Method

Maßstab Scale	Toleranz Tol.	ISO2768-m	Werkstoff Material	Sprache / Lang. / Ael. / C.I.	Blatt / Sh.
ROHDE&SCHWARZ			GRUNDEINHEIT SMB MICROWELLE BASIC UNIT SMB MICROWAVE		de en 02.00 1
SMB	Datum Date	2010-03-29	Abteilung Dept.	16PK	Name Name
				ms	1406.9045.01 D

Für dieses Dokument behalten wir uns alle Rechte vor
 For this document all rights are reserved

Projektions-
 methode

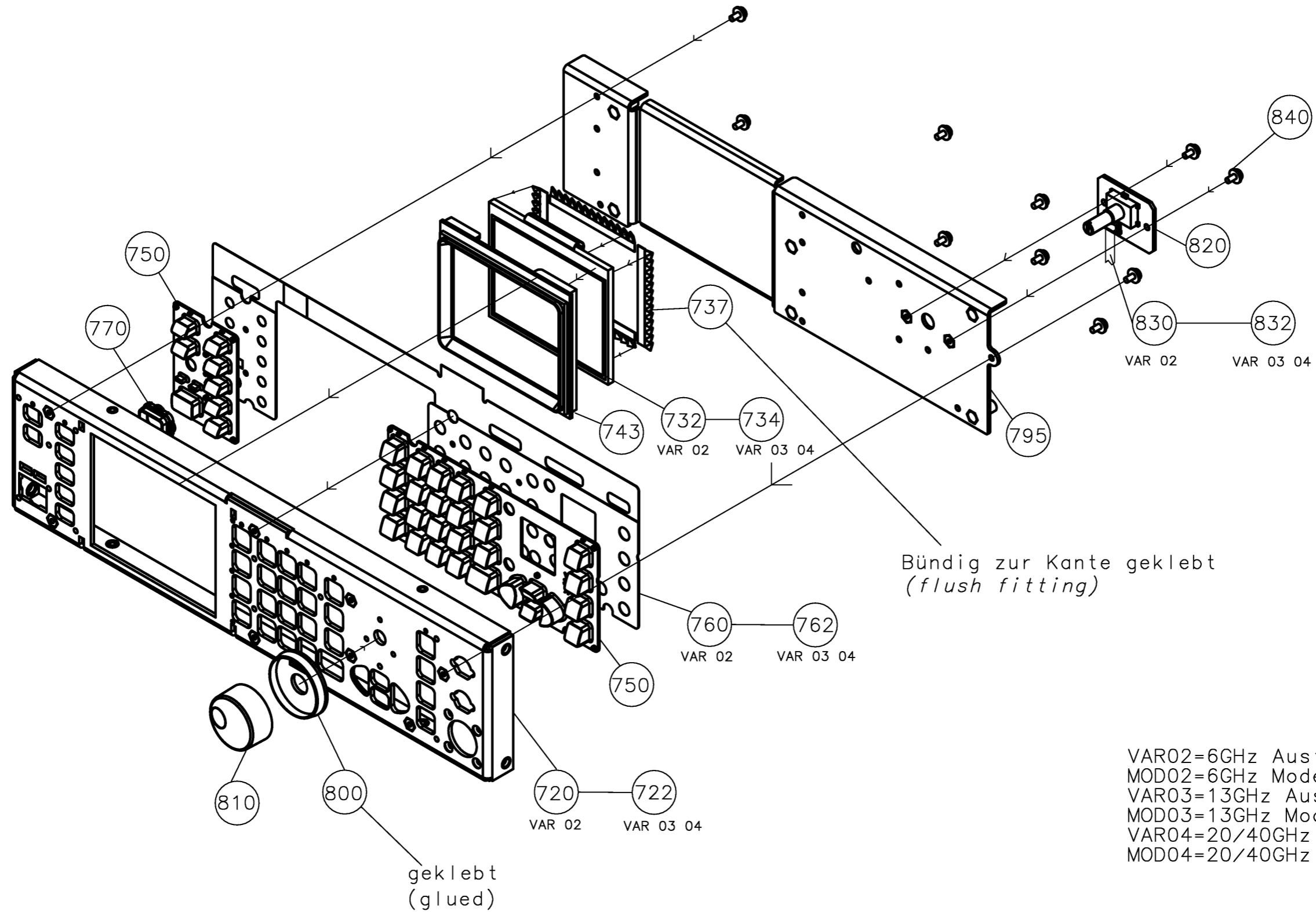
 Projection
 Method



VAR02=6GHz Ausfuehrung
 MOD02=6GHz Model
 VAR03=13GHz Ausfuehrung
 MOD03=13GHz Model
 VAR04=20/40GHz Ausfuehrung
 MOD04=20/40GHz Model

Maßstab Scale	Toleranz Tol.	Werkstoff Material	Sprache / Lang. Ael. / C.I.		Blatt / Sh.
ROHDE&SCHWARZ	FRONTINHEIT SMB100A NEUES DISPLAY FRONTUNIT SMB100A NEW DISPLAY		de en	02.00	1
SMB	Datum Date	Abteilung Dept.	Name Name	Zeichn.Nr. / Drawing No.	
	2010-02-01	1GPK	Wb/ms	1406.7820.01 D	

Für dieses Dokument behalten wir uns alle Rechte vor
 For this document all rights are reserved

Projektions-
 methode
 Projection
 Method

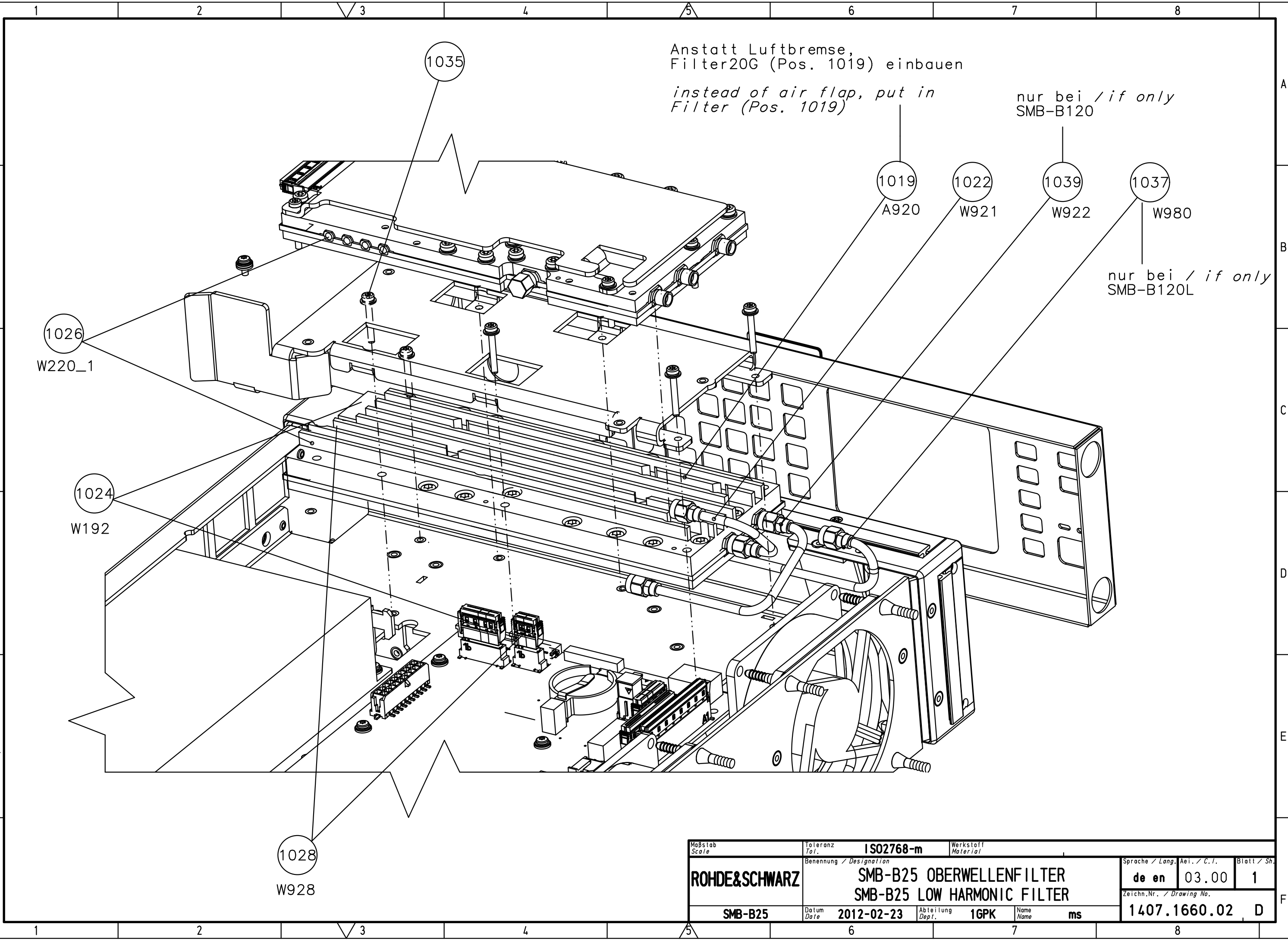

Anstatt Luftbremse,
 Filter20G (Pos. 1019) einbauen
*instead of air flap, put in
 Filter (Pos. 1019)*

nur bei / if only
 SMB-B120

nur bei / if only
 SMB-B120L

- 1019 A920
- 1022 W921
- 1039 W922
- 1037 W980

1026
 W220_1

1024
 W192

1028
 W928

Maßstab Scale	Toleranz Tol.	ISO2768-m	Werkstoff Material	Sprache / Lang. Ael. / C.I.		Blatt / Sh.
Benennung / Designation		ROHDE&SCHWARZ		de en	03.00	1
		SMB-B25 OBERWELLENFILTER SMB-B25 LOW HARMONIC FILTER		Zeichn.Nr. / Drawing No.		
Datum Date		2012-02-23	Abteilung Dept.	1GPK	Name Name	ms
SMB-B25				1407.1660.02		D

Für dieses Dokument behalten wir uns alle Rechte vor
 For this document all rights are reserved

Projektions-
 methode

 Projection
 Method

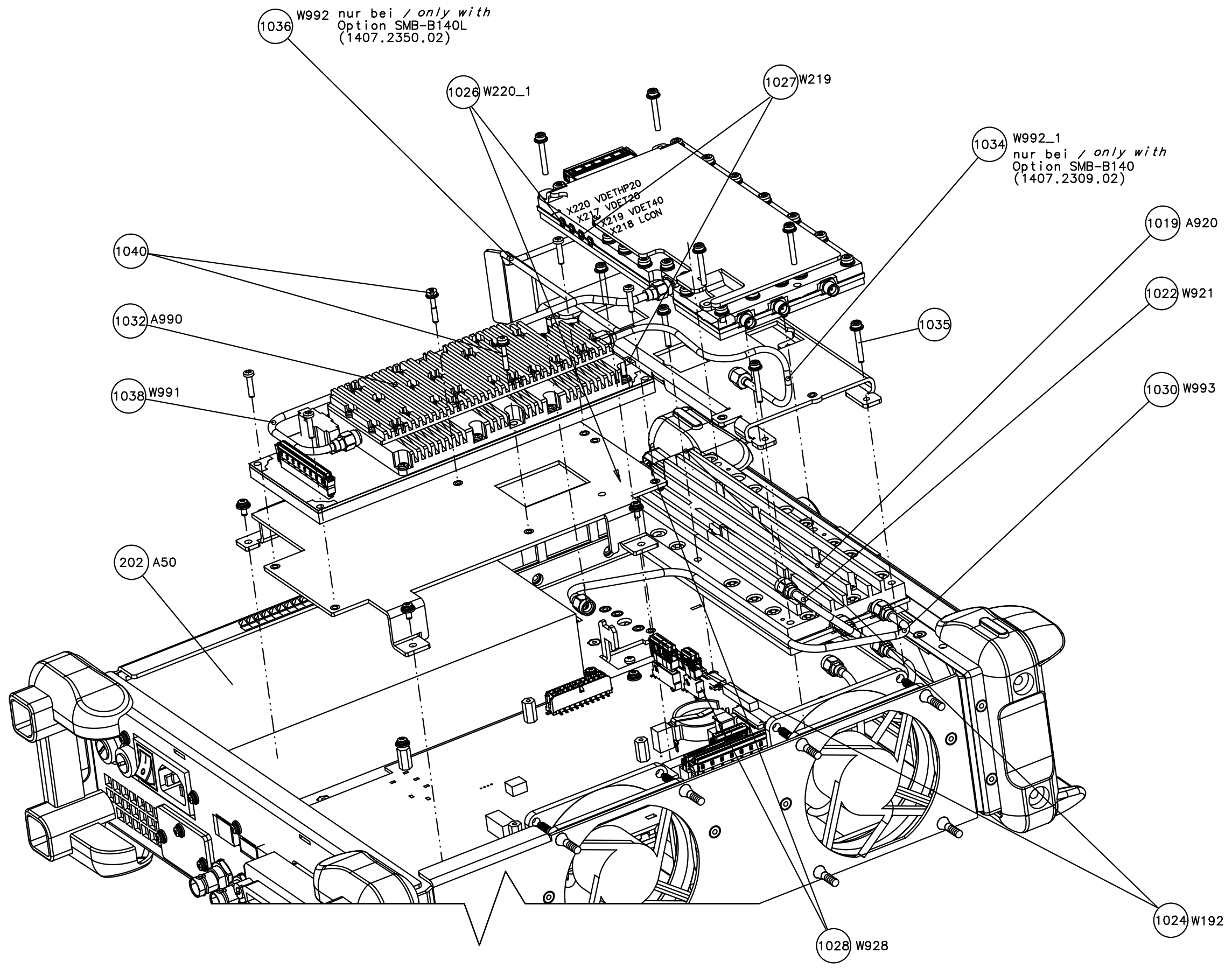

Maßstab Scale	Toleranz Tol.	ISO2768-m	Werkstoff Material	Sprache / Lang. Ael. / C.I.		Blatt / Sh.
ROHDE&SCHWARZ	Benennung / Designation		de en		02.00	1
	SMB-B26 OBERWELLENFILTER SMB-B26 LOW HARMONIC FILTER		Zeichn.Nr. / Drawing No.		1407.1760.01	D
SMB-B26	Datum Date	2012-02-16	Abteilung Dept.	1GPK	Name Name	ms

Für dieses Dokument behalten wir uns alle Rechte vor
For this document all rights are reserved

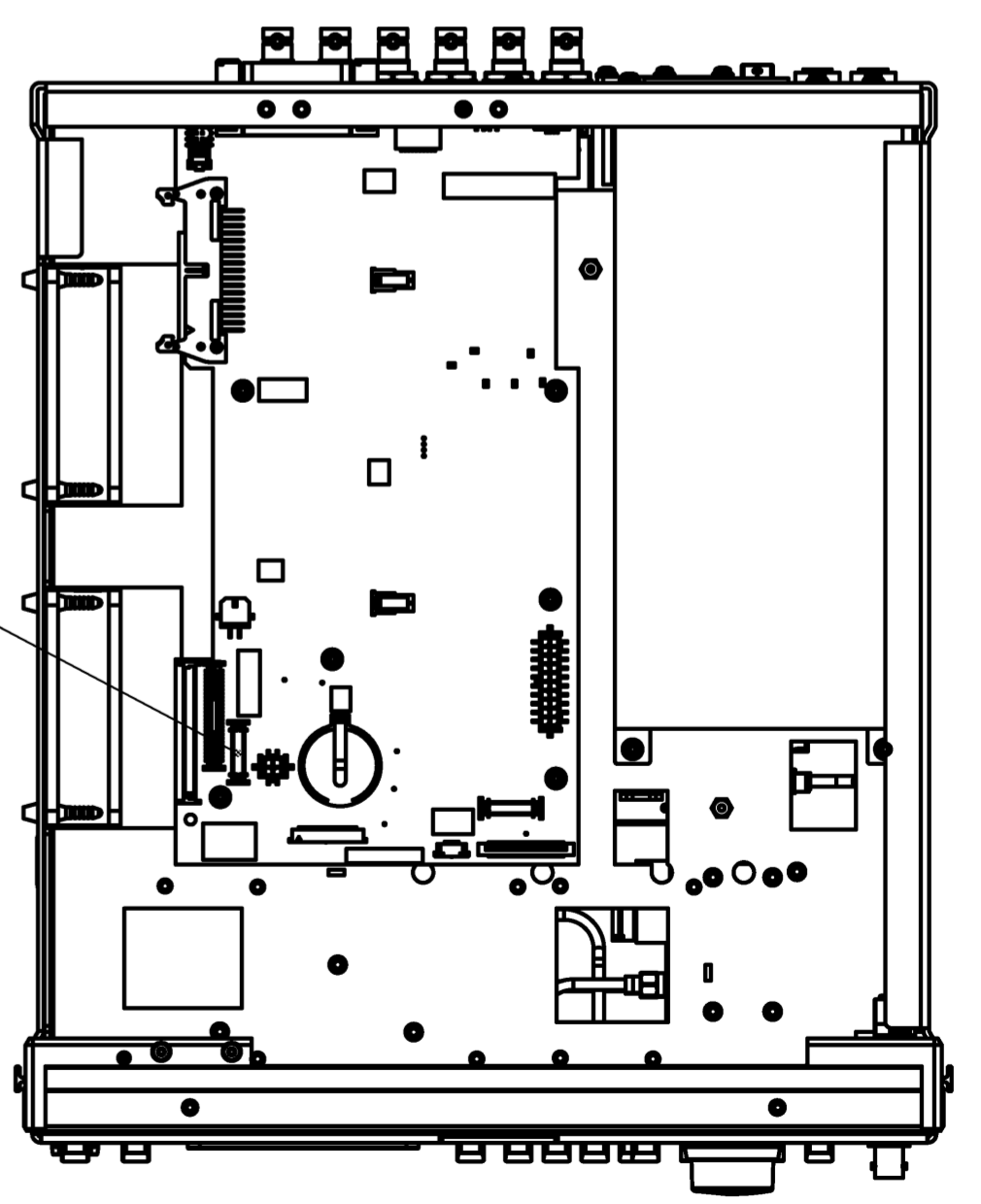
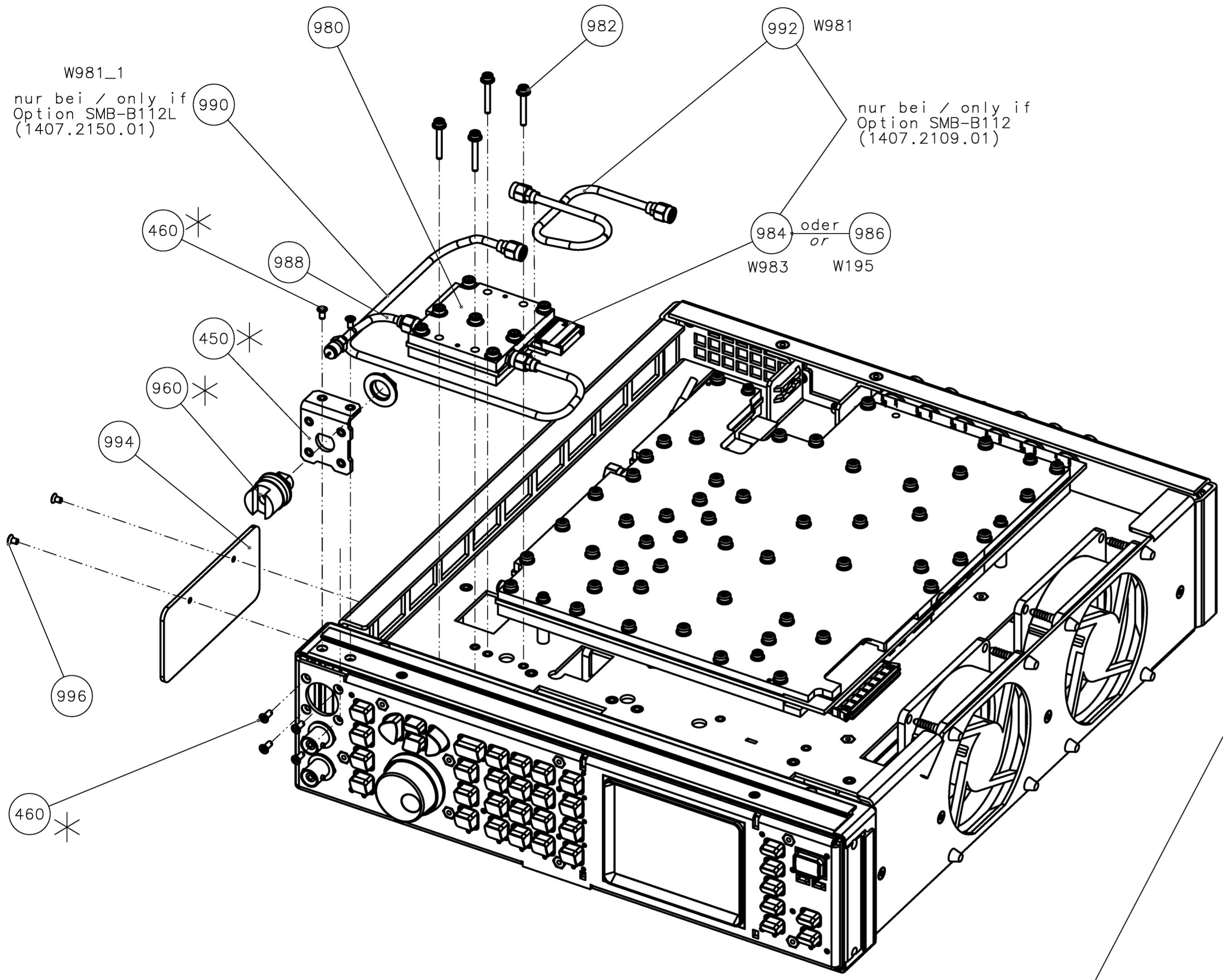

* = aus / from
1407.2109.01 (SMB-B112)
oder / or
1407.2150.01 (SMB-B112L)

986 oder 984
W195 W983

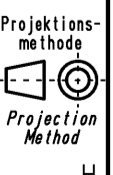

Maßstab Scale	-	Toleranz Tol.	-	Werkstoff Material	-	Sprache / Lang. Lang. / C.I.	de en	Blatt / Sh.	02.00
Benennung / Designation	ROHDE&SCHWARZ		SMB-B30 ÜBERSpannungSSCHUTZ SMB-B30 OVERVOLTAGE PROTECTION		Zeichn.Nr. / Drawing No.		1407.1160.01	1	D
Datum Date	2010-07-08	Abteilung Dept.	1GPK	Name Name	ms				

Für dieses Dokument behalten wir uns alle Rechte vor
 For this document all rights are reserved

Projektions-
 methode
 Projection
 Method

(Anstatt Luftbremse,
 High Power (Pos. 1020) einbauen)

(instead of air flap, put in
 High Power (Pos. 1020))

nur bei / if only
 SMB-B120

nur bei / if only
 SMB-B120L

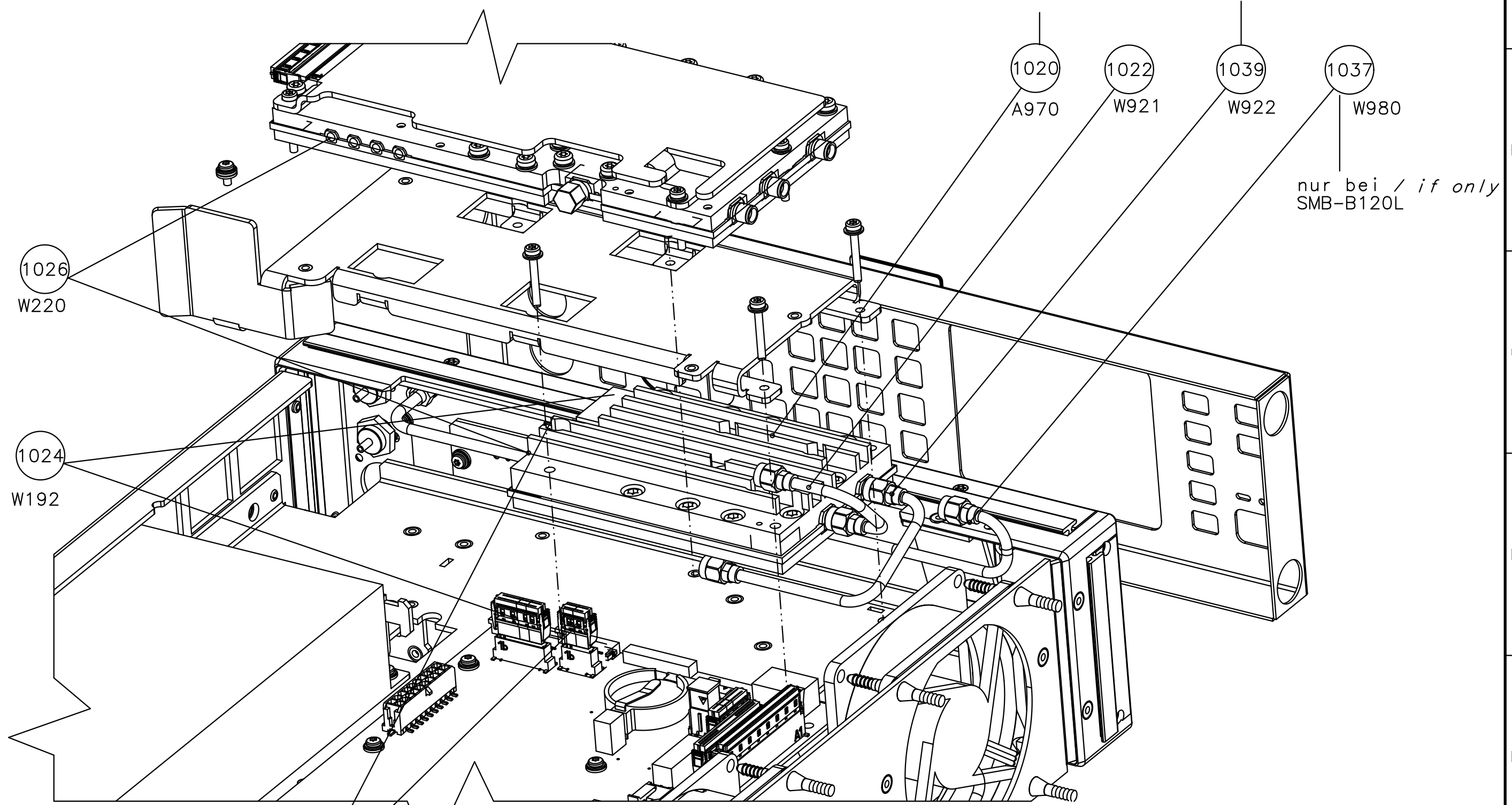

Maßstab Scale	Toleranz Tol.	ISO2768-m	Werkstoff Material	Sprache / Lang. Ael. / C.I.		Blatt / Sh.
ROHDE&SCHWARZ	Benennung / Designation		SMB-B31 HOHE AUSGANGSLEISTUNG		de en	01.00
			SMB-B31 HIGH OUTPUT POWER			1
	Datum Date	2011-05-16	Abteilung Dept.	1GPK	Name Name	ms
	Zeichn.Nr. / Drawing No.				1407.1260.01	
					D	

Für dieses Dokument behalten wir uns alle Rechte vor
 For this document all rights are reserved

Projektions-
 methode

 Projection
 Method

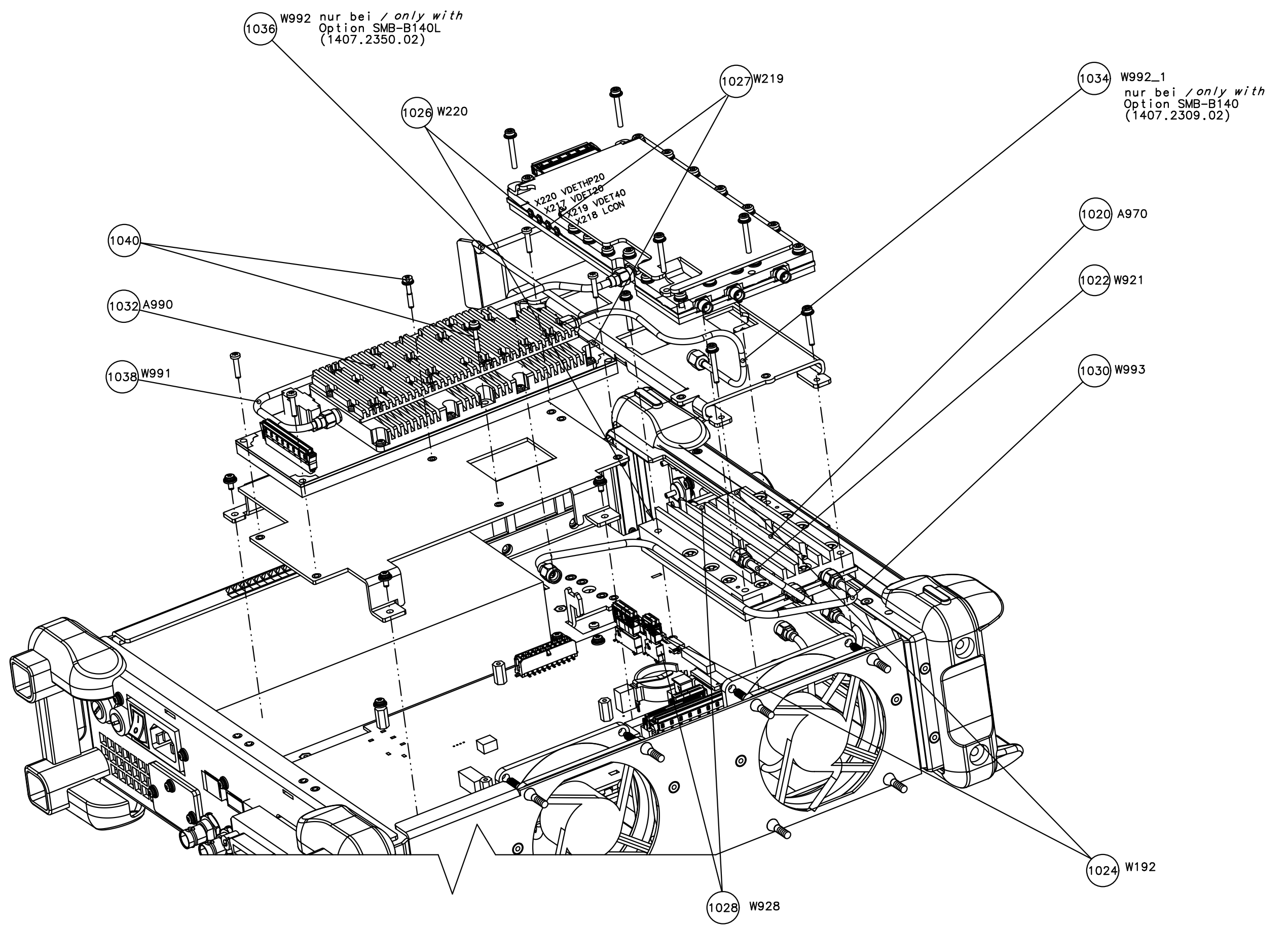

Maßstab Scale	Toleranz Tol.	ISO2768-m	Werkstoff Material	Sprache / Lang. Ael. / C.I.		Blatt / Sh.
ROHDE&SCHWARZ	Benennung / Designation		de en		03.00	1
	SMB-B32 HOHE AUSGANGSLEISTUNG SMB-B32 HIGH OUTPUT POWER		Zeichn.Nr. / Drawing No.		1407.1360.01	
SMB-B32	Datum Date	2011-07-06	Abteilung Dept.	1GPK	Name Name	ms
						D

Für dieses Dokument behalten wir uns alle Rechte vor
 For this document all rights are reserved

Projektions-
 methode
 Projection
 Method

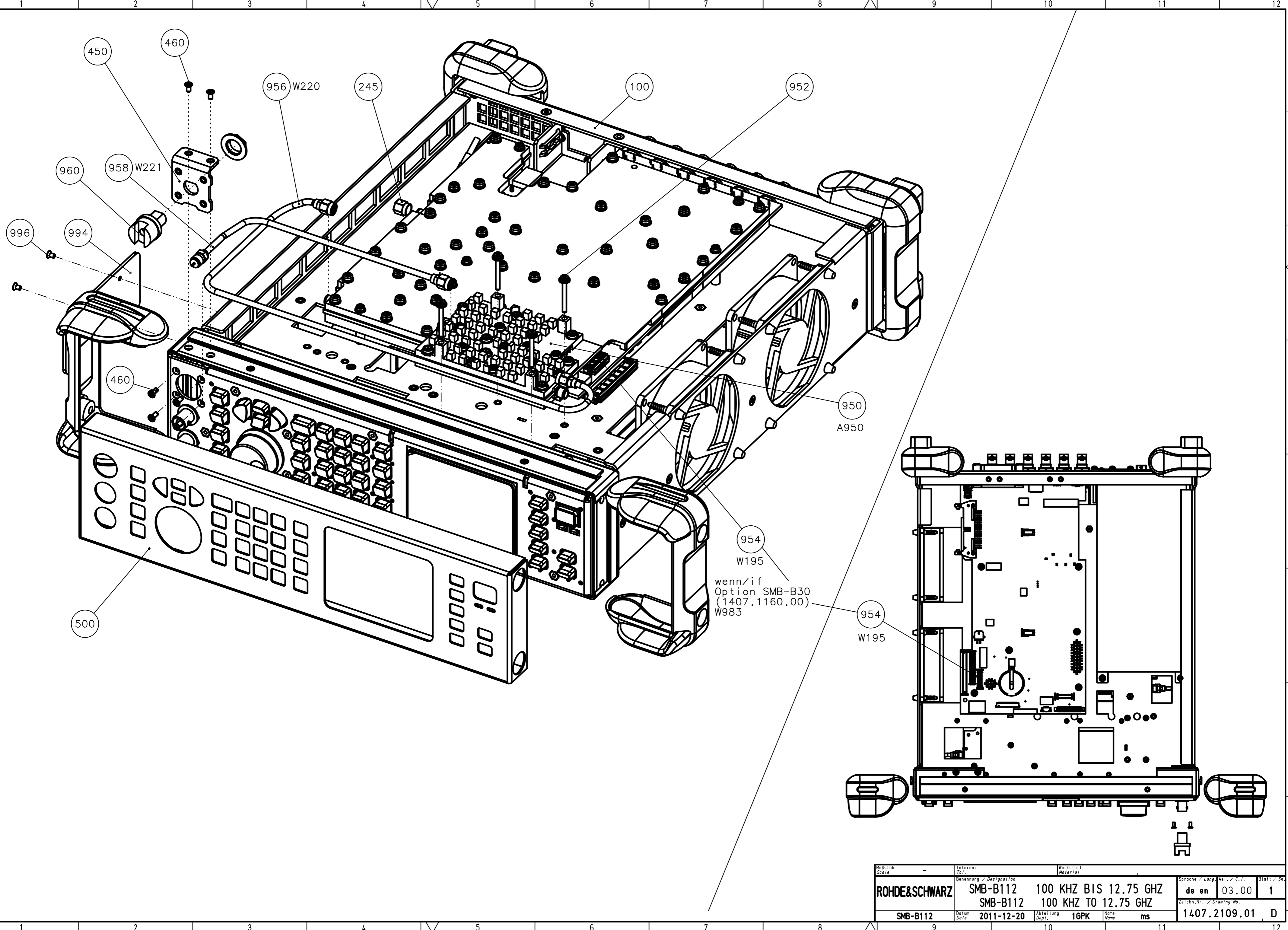

Maßstab Scale	Toleranz Tol.	Werkstoff Material	Sprache / Lang. / Ael. / C.F.	Blatt / Sh.
ROHDE&SCHWARZ	Benennung / Designation SMB-B112 SMB-B112	100 KHZ BIS 12.75 GHZ 100 KHZ TO 12.75 GHZ	de en 03.00	1
SMB-B112	Datum Date	Abteilung Dept.	Name	Zeichn.Nr. / Drawing No.
	2011-12-20	1GPK	ms	1407.2109.01 D

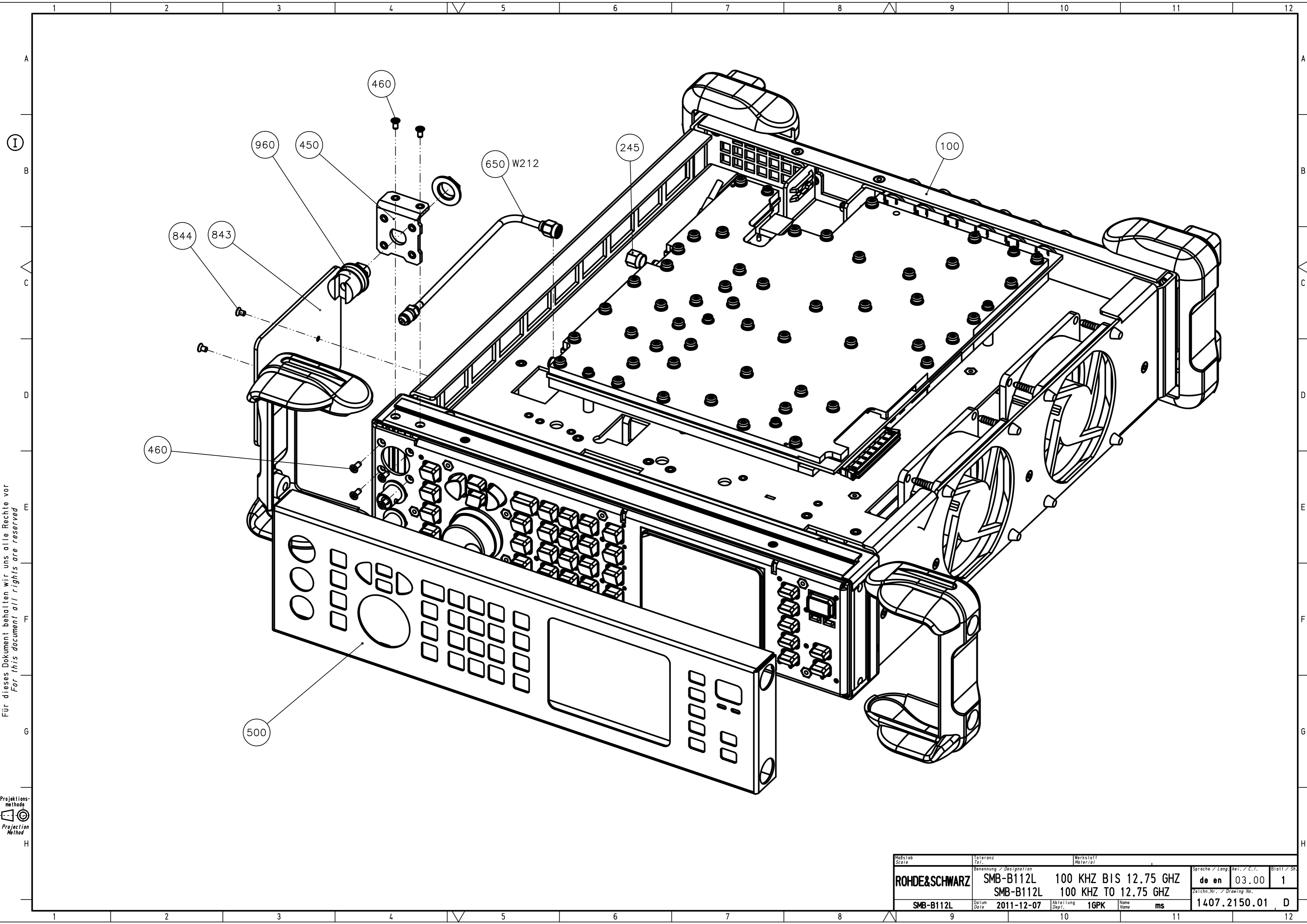

Für dieses Dokument behalten wir uns alle Rechte vor
 For this document all rights are reserved

Projektions-
 methode

 Projection
 Method

Maßstab Scale	Toleranz Tol.	Werkstoff Material	Sprache / Lang. / Rel. / C.F.	Blatt / Sh.
ROHDE&SCHWARZ	Benennung / Designation SMB-B112L SMB-B112L	100 KHZ BIS 12,75 GHZ 100 KHZ TO 12,75 GHZ	de en 03.00	1
SMB-B112L	Datum Date	Abteilung Dept.	Name Name	Zeichn.Nr. / Drawing No.
	2011-12-07	1GPK	ms	1407.2150.01 D

nicht dargestellt: Pos. 458 (X1B)
wird aussen auf Pos. 456 (X1A) angeschraubt

not represented: pos. 458 (X1B)
is external screwed on pos. 456 (X1A)

I

B

C

D

E

F

G

H

I

J

K

L

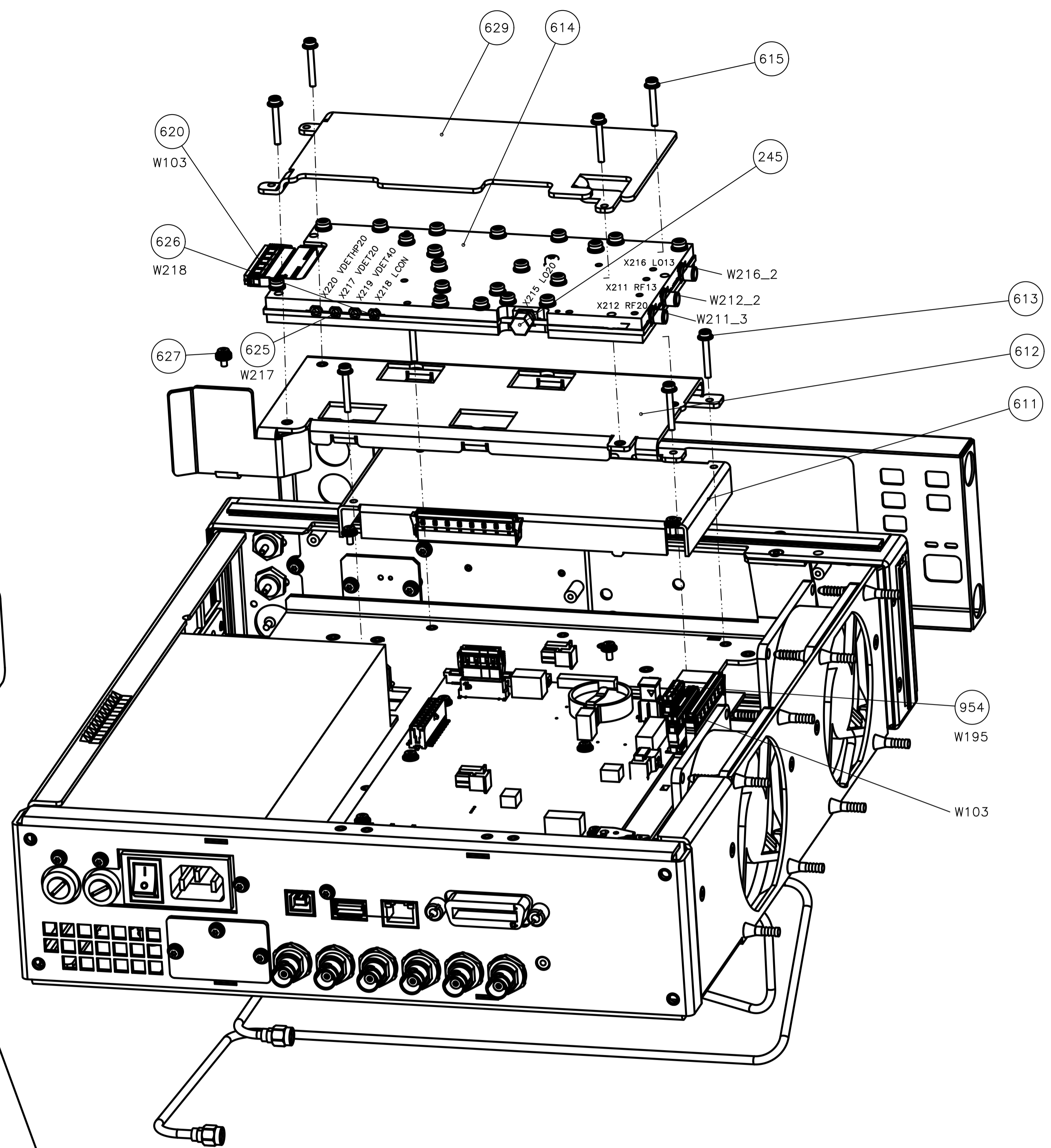
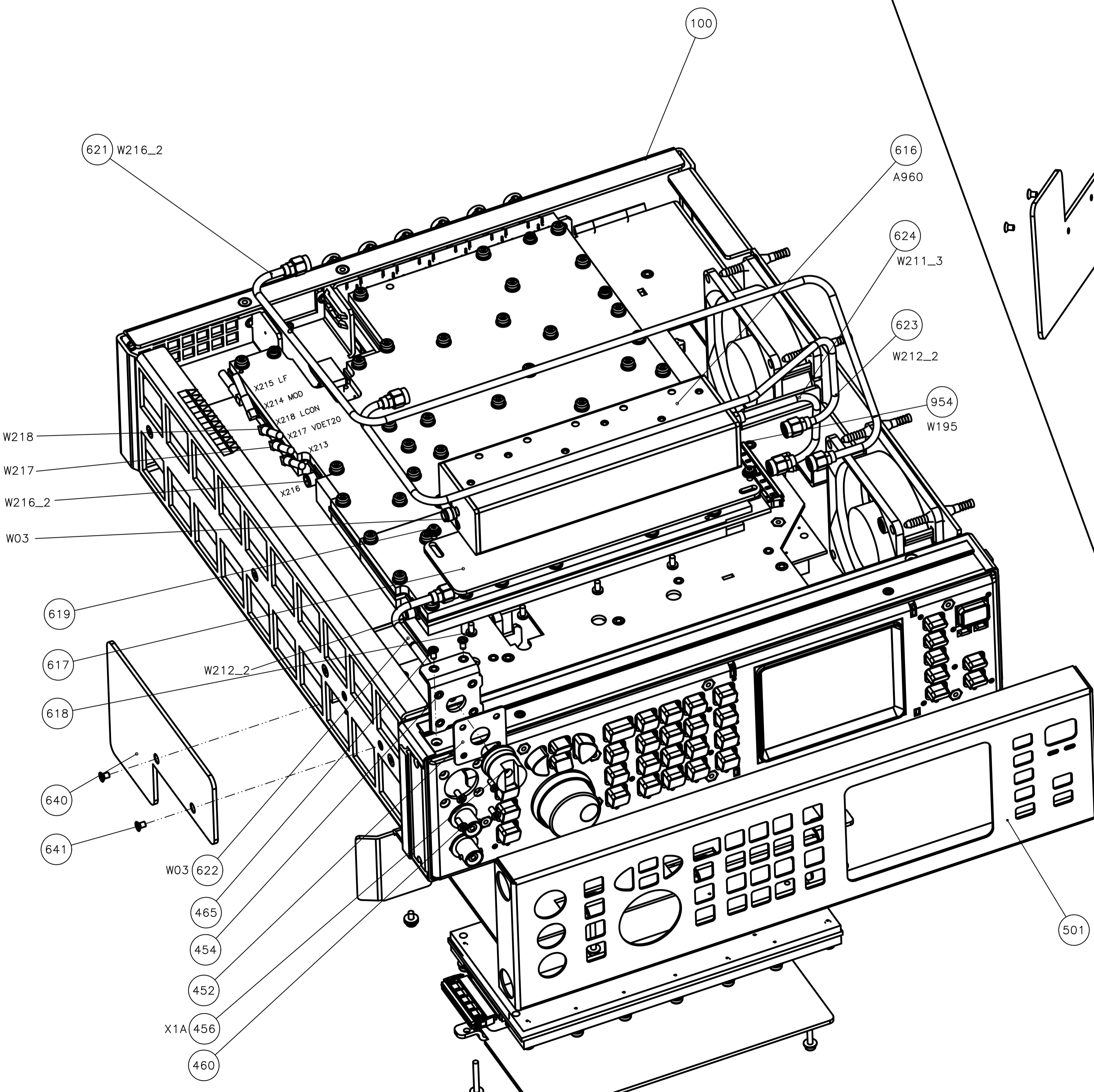

Für dieses Dokument behalten wir uns alle Rechte vor
For this document all rights are reserved

Projektions-
methode
Projection
Method

Modell Type	Bezeichnung Designation	Netzteil Power	Sprache / Lang. Lang. / C.L.	Blatt / 20
ROHDE & SCHWARZ	SMB-B120	100 KHZ BIS 20 GHZ	de en	05.00 1
SMB-B120	SMB-B120	100 KHZ TO 20 GHZ		
	Datum Date	Entwicklungs- Dept.	Name Name	Zeichn.-Nr. / Drawing No. 1407.2209.01
	2011-12-07	1GPK	ms	D

nicht dargestellt: Pos. 458 (X1B)
 wird aussen auf Pos. 456 (X1A) angeschraubt
 not represented: pos. 458 (X1B)
 is external screwed on pos. 456 (X1A)

I

B

C

D

E

F

G

H

I

J

K

L

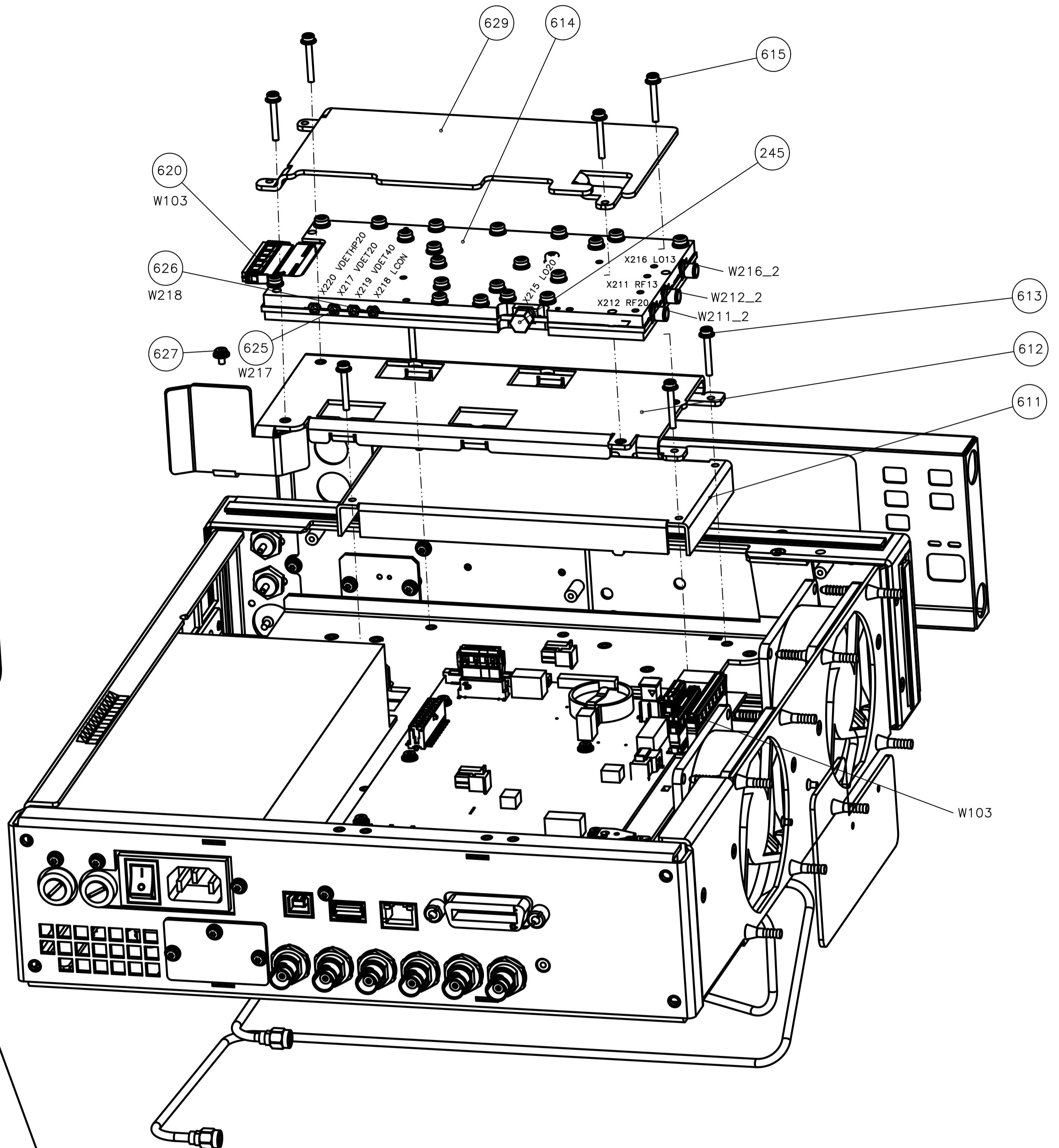
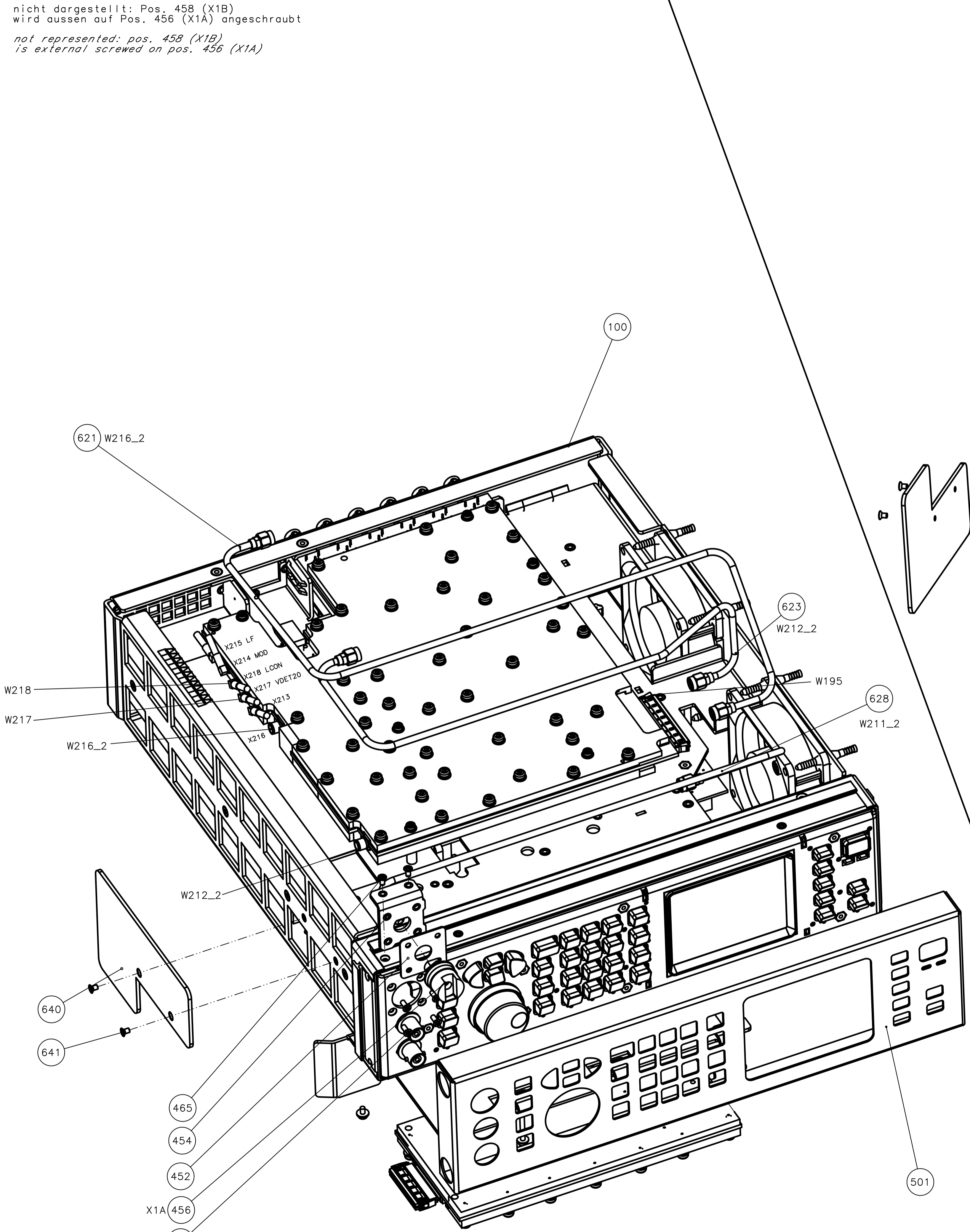

Für dieses Dokument behalten wir uns alle Rechte vor.
 For this document all rights are reserved.

Projektions-
 methode
 Projection
 Method

Modell Type	Bestanz Stock	ISQ2768-m	Netzteil Power supply	Sprache / Lang. Language	Blatt / 28
ROHDE&SCHWARZ	SMB-B120L	100 KHZ BIS 20 GHZ	de en	05.00	1
	SMB-B120L	100 KHZ TO 20 GHZ			
SMB-B120L	Datum Date	2011-12-14	Druckart Copy	1GPK	ms
				1407.2250.01	D

nicht dargestellt: Pos. 455 (X1B) wird
aussen auf Pos. 453. (X1A) aufgeschraubt

not representet: Pos. 455 (X1B)
is external screwed on Pos. 453 (X1A)

I

B

C

D

E

F

G

H

I

J

K

L

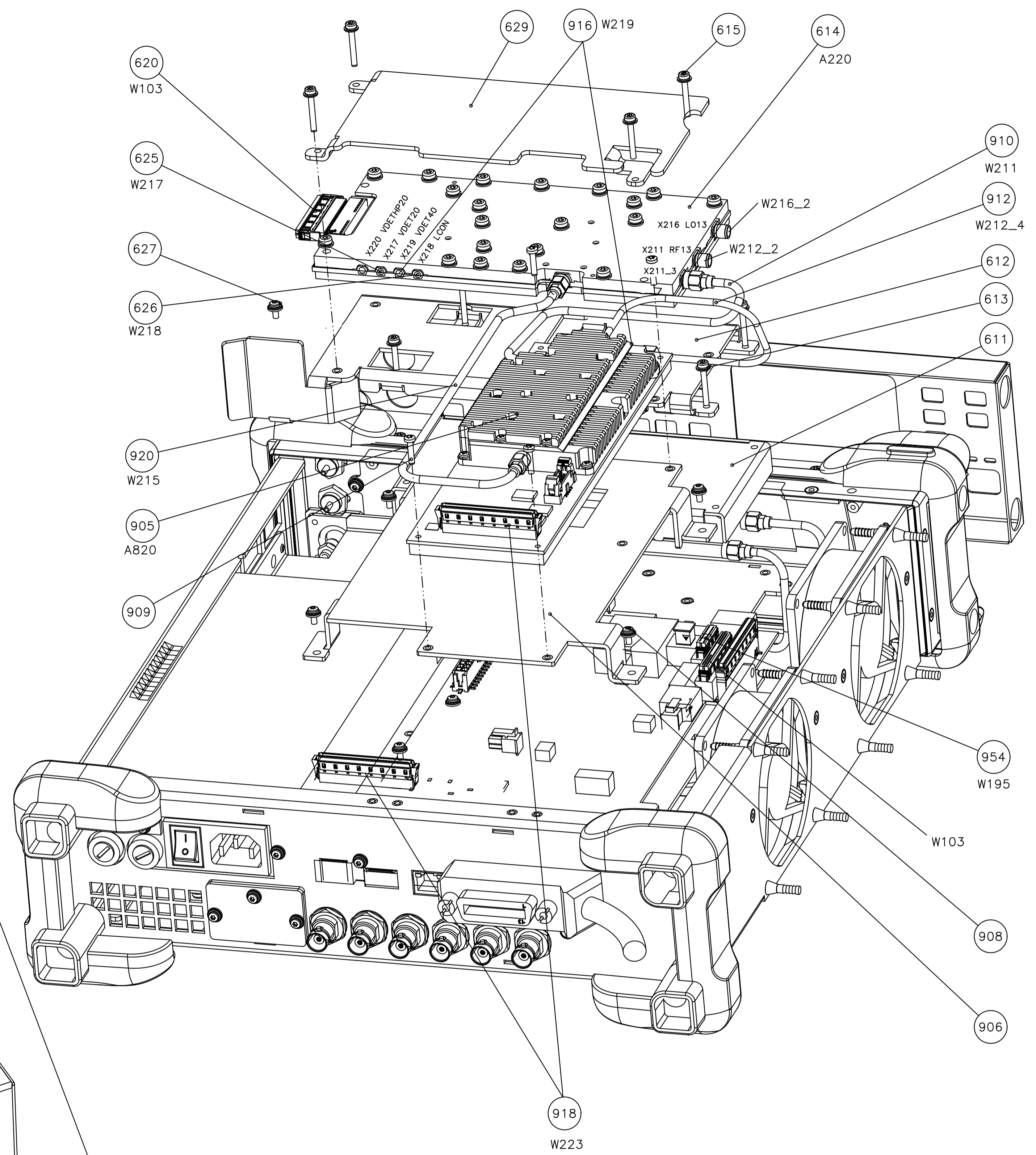
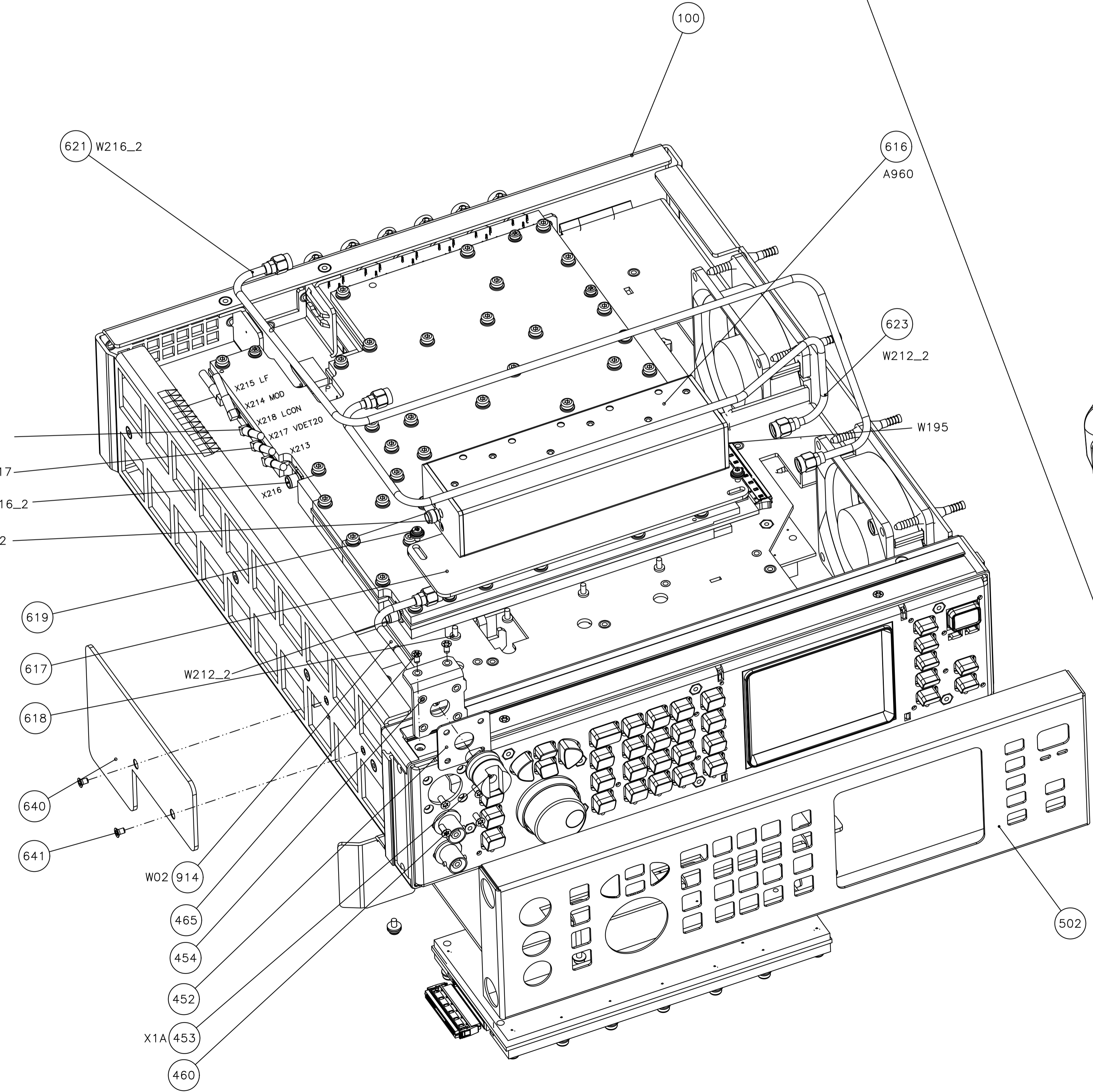

Für dieses Dokument behalten wir uns alle Rechte vor.
For this document all rights are reserved.

Projektions-
methode
Projection
Method

Modell Type	ISQ2768-m	Netzteil Power		Blatt / 28
Hersteller Manufacturer	ROHDE&SCHWARZ	Bezeichnung / Designation	SMB-B140 100 KHZ BIS 40 GHZ	Sprache / Lang. / C.F.
			SMB-B140 100 KHZ TO 40 GHZ	de en 02.00 1
Datum Date	2011-12-09	Druckart Copy	16PK	Zeichn.-Nr. / Drawing No.
				1407.2309.01 D
				ms

nicht dargestellt: Pos. 455 (X1B) wird
aussen auf Pos. 453 (X1A) aufgeschraubt

not represented: Pos. 455(X1B)
is external screwed on Pos. 453 (X1A)

I

B

C

D

E

F

G

H

I

J

K

L

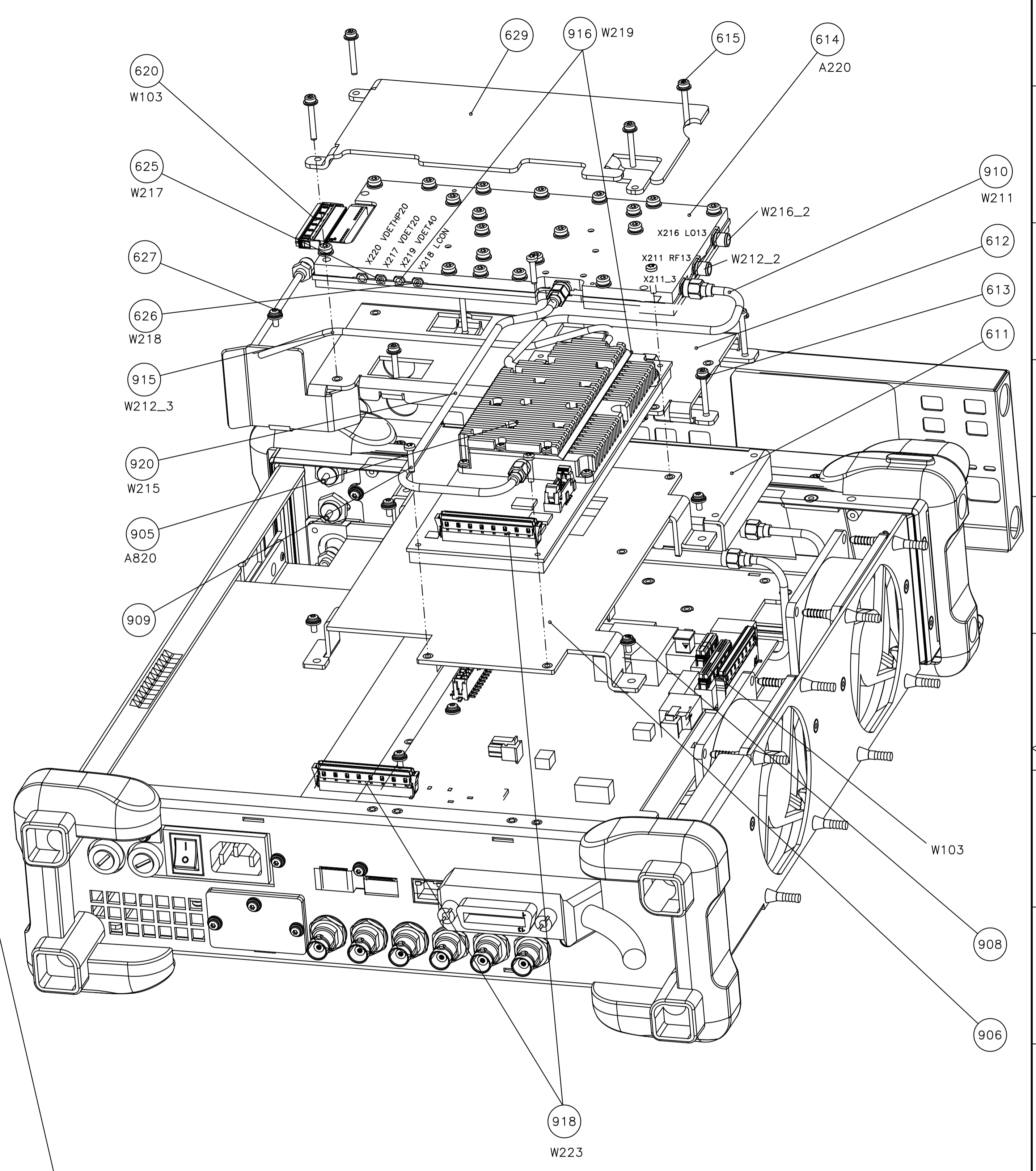
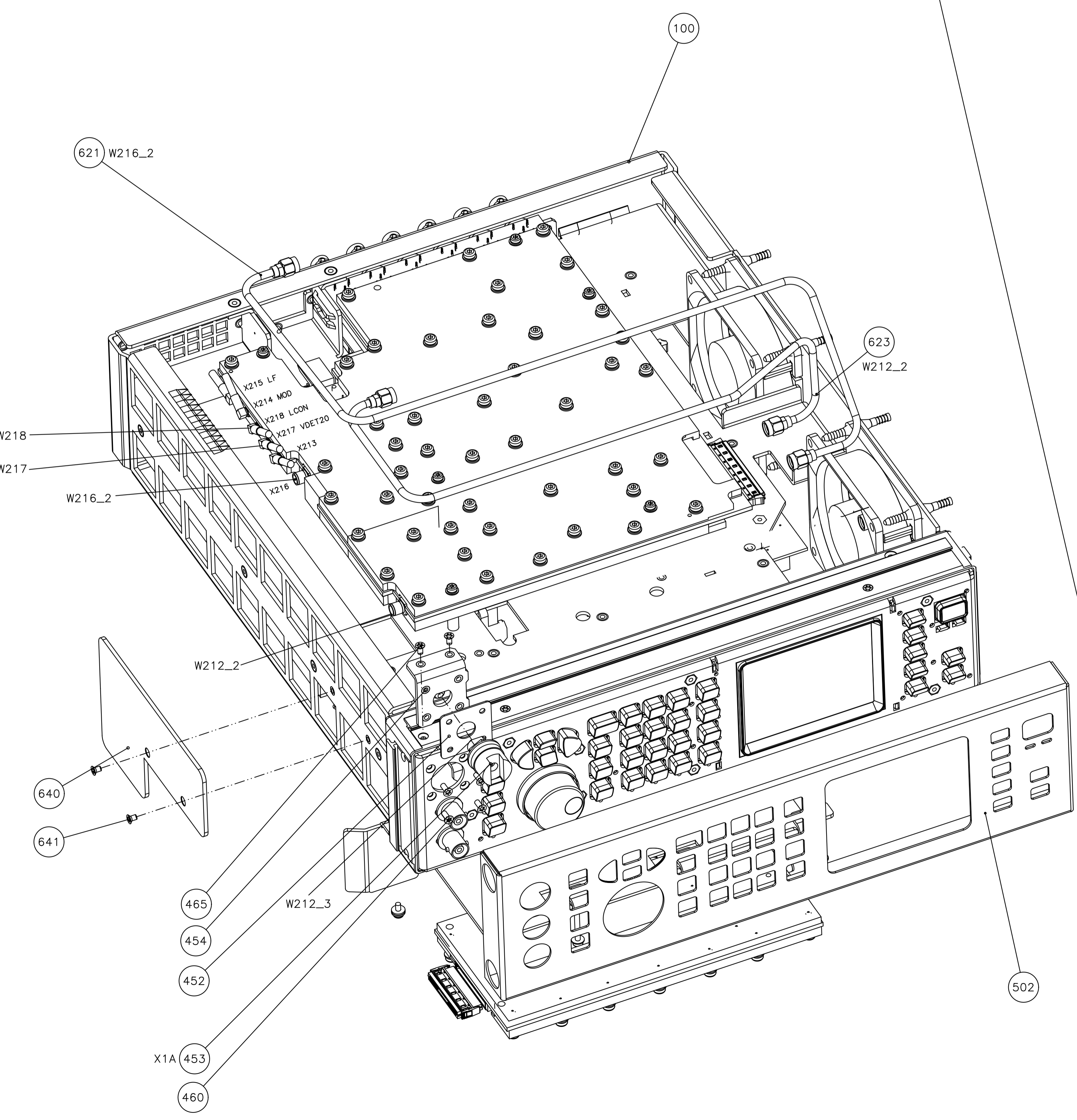

Für dieses Dokument behalten wir uns alle Rechte vor.
 For this document all rights are reserved.
 Projektions-
 methode
 Projection
 Method

Modell Type	ISQ2768-m	Netzteil Power supply	Blatt / 28
ROHDE&SCHWARZ	SMB-B140L	100 KHZ BIS 40 GHZ	de en 03.00 1
	SMB-B140L	100 KHZ TO 40 GHZ	
SMB-B140L	2011-12-16	16PK	1407.2350.01 D

Block Diagrams

SMB-B112 Options Overview

